



Victoria Government Gazette

By Authority of Victorian Government Printer

No. G 37 Thursday 17 September 2020

www.gazette.vic.gov.au

GENERAL

TABLE OF PROVISIONS

Private Advertisements	
Winding Up –	
The Denver Trust	1731
Estates of Deceased Persons	
Aitken Partners	1731
Argent Law	1731
Hicks Oakley Chessell Williams	1731
Hunt & Hunt	1731
Hutchinson Legal	1731
J. A. Middlemis	1732
JAB Lawyers	1732
Joliman Lawyers	1732
KCL Law	1732
KHQ Lawyers	1732
Kathy Wilson Legal	1733
Kennedy Guy Lawyers	1733
Kensington Lawyers	1733
Maddens Lawyers	1733
Moores	1733
O’Brien & Black	1734
O’Hanlon Foster Lawyers	1734
Pietrzak Solicitors	1734
Russo Pellicano Carlei	1734
Suzanne Lyttleton Lawyers	1734
Whiting Lawyers	1735
Government and Outer Budget Sector	
Agencies Notices	1736
Orders in Council	1976
Crown Land (Reserves);	
Road Safety	

Advertisers Please Note

As from 17 September 2020

The last Special Gazette was No. 470 dated 16 September 2020.

The last Periodical Gazette was No. 1 dated 3 June 2020.

How To Submit Copy

- See our webpage www.gazette.vic.gov.au
 - or contact our office on 8523 4601
between 8.30 am and 5.30 pm Monday to Friday
-

PRIVATE ADVERTISEMENTS

THE DENVER TRUST – Victoria
THE DENVER TRUST
(ABN 25 123 082 326) (the Trust).

U-I Australia Pty Ltd (ACN 161 800 068) as trustee of The Denver Trust (ABN 25 123 082 326) (the Trust), which previously owned property at Building 10, 658 Church Street, Richmond, Victoria, intends to distribute its the remaining Trust assets and terminate (wind up) the Trust and be wound up. Creditors, and others having claims in respect of the estate the Trust, are required by the trustee, U-I Australia Pty Ltd, care of McGrathNicol, GPO Box 9986, Sydney, New South Wales 2001, to send particulars of their claims, relating to the Trust, to them by 18 November 2020, after which date the trustee may convey or distribute the Trust assets, having regard only to the claims of which it he then has notice.

Please contact Louise Mann on +61(2)9338 2623 or lmann@mcgrathnicol.com if you have any queries.

Dated 17 September 2020

Creditors, next-of-kin and others having claims in respect of the estate of HELEN FAYE ELSTON, deceased, late of Elanora Aged Care, 7 Mair Street, Brighton East, Victoria, accountant, who died on 29 May 2020, are requested to send particulars of their claims to the executor, Raymond Alwyn Elston, care of the undersigned solicitors, by 20 November 2020, after which date he will convey or distribute the assets, having regard only to the claims of which he then has notice.

AITKEN PARTNERS, solicitors,
Level 28, 140 William Street, Melbourne 3000.

HANNE MARY CHENHALL, late of 4 Reserve Road, Mount Dandenong, Victoria 3767, retired, deceased.

Creditors, next-of-kin and others having claims in respect of the estate of the abovenamed deceased, who died on 31 March 2020, are required by the trustees, Antony James Chenhall and Christopher John Chenhall, to send particulars of their claims to the undermentioned firm by 22 November 2020, after which date the

said trustees may convey or distribute the estate, having regard only to the claims of which they then have notice. Probate was granted in Victoria on 7 September 2020.

ARGENT LAW,
2 Stawell Street, Richmond, Victoria 3121.
Ph: (03) 9571 7444. Contact: Helen Adoranti.

Re: Estate of BERYL MARY TWEED.

Creditors, next-of-kin and others having claims against the estate of BERYL MARY TWEED, late of Unit 63, 95 Outer Crescent, Brighton, Victoria, retired, deceased, who died on 6 July 2020, are requested to send particulars of their claims to the executor, care of the undermentioned lawyers, by 19 November 2020, after which date he will distribute the assets, having regard only to the claims of which he then has notice.

HICKS OAKLEY CHESSELL WILLIAMS,
lawyers,
PO Box 2165, Mount Waverley, Victoria 3149.

Trustee Act 1958

SECTION 33 NOTICE

Notice to Claimants

PAULINE MARY BAKES, late of 14 Abercairn Court, Deer Park, Victoria, retired nurse, deceased.

Creditors, next-of-kin and others having claims in respect of the estate of the deceased, who died on 17 March 2020, are required by Equity Trustees Wealth Services Limited, ACN 006 132 332, of Level 1, 575 Bourke Street, Melbourne, Victoria, the executor of the estate of the deceased, to send particulars of their claims by 17 November 2020, after which date the executor may convey or distribute the assets, having regard only to the claims of which it then has notice.

HUNT & HUNT,
Level 5, 114 William Street, Melbourne,
Victoria 3000.
Ref: 9632671.

NGAN YONG CHAN, late of Unit 2, 5 Lauri-ann Street, Templestowe Lower, Victoria 3107, retired, deceased.

Creditors, next-of-kin and others having claims in respect of the estate of the deceased, who died on 17 April 2020, are required by the

personal representative, Anna Oi Lin Wong, to send particulars of such claims to her, care of the undersigned, by 16 November 2020, after which date the personal representative may convey or distribute the assets, having regard only to the claims of which she then has notice.

HUTCHINSON LEGAL,
38 New Street, Ringwood, Victoria 3134.

NORMA ISOBEL ROBERTSON, late of 4 Oscar Place, Echuca, Victoria, home duties, deceased.

Creditors, next-of-kin and others having claims in respect of the estate of the abovenamed deceased, who died on 17 May 2020, are required by Amanda Doone Robertson and Jillian Ann Robertson, the executors of the Will of the deceased, to send particulars of their claims to them, care of the undermentioned address by 17 November 2020, after which date the executors may convey or distribute the assets, having regard only to the claims of which they then have notice.

J. A. MIDDLEMIS, barrister and solicitor,
30 Myers Street, Bendigo, Victoria 3550.

FRANK VESCIO, in the Will called Francesco Vescio, late of 42 Cambala Avenue, Lalor, Victoria 3075, tradesperson.

Creditors, next-of-kin and others having claims in respect of the estate of the abovementioned deceased, who died on 27 August 2019, are required by the personal representatives, Amando Vescio (in the Will called Armando Vescio) and Giovanna Manley (in the Will called Joan Manley), to send particulars of their claims to them, care of the undermentioned solicitors, by 21 November 2020, after which date the personal representatives may convey or distribute the assets, having regard only to the claims of which they then have notice.

JAB LAWYERS,
PO Box 16, Brunswick West 3055.
jablawyers@gmail.com

Re: Estate of SUSANNA HENDERSON.

Creditors, next-of-kin or others having claims in respect of the estate of SUSANNA HENDERSON, late of Cunningham Downs, 21 Hartshorn Drive, Echuca, in the State of Victoria, retired, deceased, who died on 13 July 2020, are to send particulars of their claim to the executors, care of the undermentioned legal

practitioners, by 30 November 2020, after which the executors will distribute the assets, having regard only to the claims of which they then have notice.

JOLIMAN LAWYERS,
Beveridge Dome, 194–208 Beveridge Street,
Swan Hill 3585.

Re: Estate of OLGA FRANCES SCHODDE.

Creditors, next-of-kin or others having claims in respect of the estate of OLGA FRANCES SCHODDE, late of 19 Armstrong Street, Boort, in the State of Victoria, widow, deceased, who died on 10 August 2020, are to send particulars of their claim to the executors, care of the undermentioned legal practitioners, by 2 December 2020, after which the executors will distribute the assets, having regard only to the claims of which they then have notice.

JOLIMAN LAWYERS,
Beveridge Dome, 194–208 Beveridge Street,
Swan Hill 3585.

EVAN SKLIROS, late of 101 Punt Road, Windsor, Victoria 3181, deceased.

Creditors, next-of-kin and all others having claims in respect of the estate of the deceased, who died on 20 February 2019, are required by the executors, Jenny Velakoulis and Bill Evan Skliros (otherwise known as Vasillios Skliros), to send particulars of such claims to the executors, care of the undermentioned solicitors, within 60 days from the publication hereof, after which date the executors will distribute the assets, having regard only to the claims of which the executors have notice.

KCL LAW,
Level 4, 555 Lonsdale Street, Melbourne 3000.
nfedyszyn@kcllaw.com.au

Re: SHIRLEY ELLEN DREDGE, late of 23 Alexandra Avenue, Lakes Entrance, Victoria, deceased.

Creditors, next-of-kin and others having claims in respect of the estate of the deceased, who died on 22 October 2019, are required by the trustee, Equity Trustees Wealth Services Limited, ACN 006 132 332, of 1/575 Bourke Street, Melbourne, Victoria, to send particulars

to the trustee, care of the undermentioned solicitors, by 20 November 2020, after which date the trustee may convey or distribute the assets, having regard only to the claims of which the trustee then has notice.

KHQ LAWYERS,
Level 4, 600 Bourke Street, Melbourne,
Victoria 3000.

Re: FRANCISCO JOSE AMENEIRO PALACIOS, also known as Frank Ameneiro, late of Thailand, deceased.

Creditors, next-of-kin and others having claims in respect of the estate of the deceased, who died on 3 March 2019 are required by the trustee, Suthasinee Pradutnam, care of Level 4, 600 Bourke Street, Melbourne, Victoria, to send particulars to the trustee, care of the undermentioned solicitors, by 18 November 2020, after which date the trustee may convey or distribute the assets, having regard only to the claims of which the trustee then has notice.

KHQ LAWYERS,
Level 4, 600 Bourke Street, Melbourne,
Victoria 3000.

Re: PHILLIP WILLIAM JONES, late of 34 Station Road, Williamstown, in the State of Victoria, teacher, deceased.

Creditors, next-of-kin and others having claims in respect of the estate of the abovenamed deceased, who died on 23 April 2020, are required by the trustee, Robyn Cottrill, to send particulars to their claims, care of the undermentioned solicitors, by 17 November 2020, after which date the trustee may convey or distribute the assets, having regard only to the claims of which the trustee then has notice.

KATHY WILSON LEGAL,
113 Whitehorse Road, Deepdene, Victoria 3103.

Re: BETTY JEAN CLARK, late of Melton, Victoria.

Creditors, next-of-kin and others having claims in respect of the estate of the deceased, who died on 5 September 2018, are required to send particulars of their claims to the executor, care of Kennedy Guy Lawyers, 12 Hertford

Road, Sunshine, Victoria 3020, by 9 October 2020, after which date the executor may convey or distribute the assets, having regard only to the claims of which they may then have notice.

KENNEDY GUY LAWYERS,
12 Hertford Road, Sunshine, Victoria 3020.

GLORIA CORINNE GRAY, late of Unit 4, 12 Raynes Street, Balwyn, Victoria, pensioner, deceased.

Creditors, next-of-kin and others having claims in respect of the estate of the abovenamed deceased, who died on 31 December 2019, are required by the executor, Kim Hock Tay, to send particulars of their claims to him, care of the undermentioned solicitors, within two months from the date of publication of this notice, after which date the executor may convey or distribute the assets, having regard only to the claims of which he then has notice.

KENSINGTON LAWYERS,
301A Racecourse Road, Kensington,
Victoria 3031.

JOHN DOUGLAS HANNAFORD, late of Unit 9, 38 Grove Street, Eltham, in the State of Victoria, retired producer, deceased.

Creditors, next-of-kin and others having claims in respect of the estate of the deceased, who died on 11 February 2020, are required by the trustees, Richard Wainwright Hannaford and Cecily Hughenden Hannaford, to send particulars of their claims to them, care of the undermentioned solicitors, by 16 November 2020, after which date the trustees may convey or distribute the assets, having regard only to the claims of which they have notice.

MADDENS LAWYERS,
219 Koroit Street, Warrnambool, Victoria 3280.
Phone: (03) 5560 2000.

Re: LUDMILLA DUNCAN, deceased.

Creditors, next-of-kin and others having claims in respect of the estate of the deceased, who died on 4 July 2019, are required by the legal representative, Neil Clifford Duncan, to send particulars to the legal representative, care of Moores, Level 1, 5 Burwood Road, Hawthorn,

Victoria, by 21 November 2020, after which date the legal representative may convey or distribute the assets, having regard only to the claims of which the legal representative has notice.

MOORES,
Level 1, 5 Burwood Road, Hawthorn,
Victoria 3122.

PATRICIA MARGARET ASHLEY, late of 29 Wonga Road, Millgrove, Victoria 3799, social worker, deceased.

Creditors, next-of-kin and others having claims in respect of the Will/estate of the abovenamed deceased, who died on 29 March 2020, are required by the trustee, Carolyn Anne Ashley, care of 222 Maroondah Highway, Healesville, Victoria 3777, to send particulars of their claims to her by 10 November 2020, after which date the trustee may convey or distribute the assets, having regard only to the claims of which the trustee has notice. Probate was granted in Victoria on 6 August 2020.

BERYL JEAN FISK, late of 17 Crescent Road, Yarra Junction, Victoria 3797, home duties, deceased.

Creditors, next-of-kin and others having claims in respect of the Will/estate of the abovenamed deceased, who died on 17 February 2020, are required by the trustee, Jennifer Kay Cole, care of 222 Maroondah Highway, Healesville, Victoria 3777, to send particulars of their claims to her by 10 November 2020, after which date the trustee may convey or distribute the assets, having regard only to the claims of which the trustee has notice. Probate was granted in Victoria on 24 July 2020.

CHRISTIE ELIZABETH KERMEEN, late care of O'Hanlon Foster Lawyers, PO Box 3215, Victoria Gardens, Richmond, Victoria 3121, deceased.

Creditors, next-of-kin and others having claims in respect of the estate of the abovenamed deceased, who died on 24 May 2018, are required by the applicant for grant of administration, Maureen Anne Kermeen, care of O'Hanlon Foster Lawyers, PO Box 3215, Victoria Gardens, Richmond, Victoria 3121, to send particulars of their claims to her by 24 November 2020, after

which date the administrator may convey or distribute the assets and distribute the estate, having regard only to the claims of which she then has notice.

Letters of Administration were granted in Victoria on 26 November 2018.

Dated 9 September 2020

O'HANLON FOSTER LAWYERS,
PO Box 3215, Victoria Gardens, Victoria 3121.
Ph: 0416 258 442.
SOH:180158. Contact: Simon O'Hanlon.

Creditors, next-of-kin and others having claims in respect to the estate of HELENA PAWLICKI, late of 4 Krithia Street, Coburg North, Victoria 3073, pensioner, deceased, who died on 10 April 2020, are required to send particulars of such claims to the executor, care of the undermentioned solicitors, by 24 November 2020, after which date the executor will convey or distribute the assets, having regard only to the claims of which the executor then has notice.

PIETRZAK SOLICITORS,
832 High Street, Kew East, Victoria 3102.

Re: PATRICIA RUTH HART, late of 4 Ring Court, Dandenong North, in the State of Victoria, pensioner, deceased.

Creditors, next-of-kin and others having claims in respect of the estate of the deceased, who died on 20 May 2020, are required by Helen Louise Hart, the trustee of the estate of the deceased, to send particulars of their claims to her, care of the undermentioned lawyers, by 17 November 2020, by which date the trustee may convey or distribute the assets, having regard only to the claims of which the trustee has notice.

RUSSO PELLICANO CARLEI, lawyers,
43 Atherton Road, Oakleigh, Victoria 3166.

Re: GRIGORIA KLONIS, late of 14 David Street, Preston, widow, deceased.

Creditors, next-of-kin and others having claims in respect of the estate of the deceased, who died on 13 December 2019, are required by the executors, Nectarios Klonis and Evangelos Klonis, to send particulars to them, care of the undermentioned lawyers, by a date not later than

two months from the date of publication hereof, after which date the executors will convey or distribute the assets, having regard only to the claims of which they then have notice.

SUZANNE LYTTLETON LAWYERS,
PO Box 2181, St Kilda West, Victoria 3182.
Telephone: 9646 4477.

Re: ANTONIO TOMAINO, late of
10 Frederick Street, Dandenong, Victoria,
deceased.

Creditors, next-of-kin, grandchildren and others having claims in respect of the estate of the deceased, who died on 22 December 2019, are required by the personal representative, Filippo Tomaino, care of the undermentioned solicitors, to send particulars to him, care of the undermentioned solicitors, by 18 November 2020, after which date the trustee may convey or distribute the assets, having regard only to the claims of which he then has notice.

WHITING LAWYERS,
Level 4, 180 Queen Street, Melbourne 3000.

**GOVERNMENT AND OUTER BUDGET
SECTOR AGENCIES NOTICES**

MORELAND CITY COUNCIL
Road Discontinuance

Pursuant to section 206 and Schedule 10, Clause 3 of the **Local Government Act 1989**, the Moreland City Council at its ordinary meeting held on 9 September 2020, resolved to discontinue a subterranean stratum of Duckett Street, Brunswick, shown by hatching on the plan below and to sell the land from the road by private treaty to the abutting property owners.

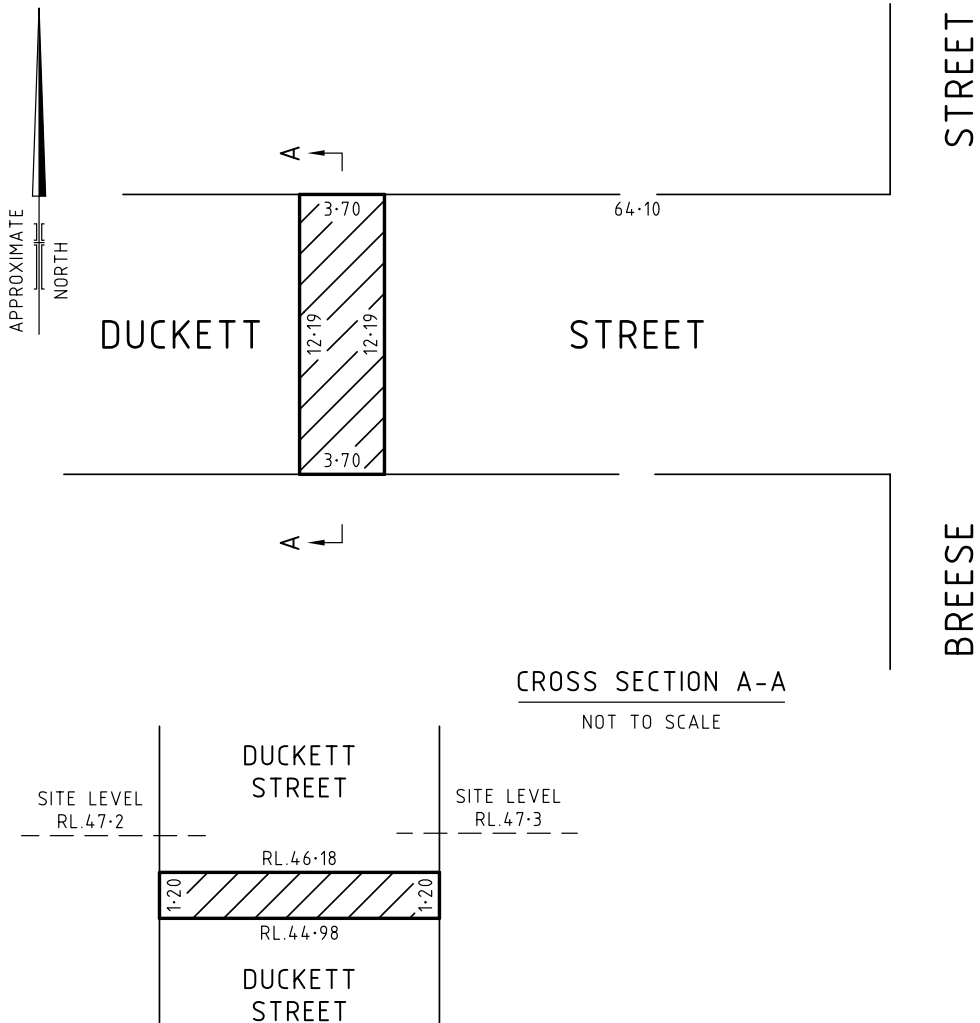

CATHY HENDERSON
Chief Executive Officer



ROAD DISCONTINUANCE

Pursuant to section 206, Schedule 10, Clause 3 of the **Local Government Act 1989**, the Whitehorse City Council at its meeting held on 24 August 2020, resolved to discontinue the sections of road and pedestrian pathway shown hatched on the plan below and to retain the land in the sections of discontinued road and pathway. The sections of road and pathway discontinued and retained are sections of road and pathway located within the property boundary of 379–399 Whitehorse Road, Nunawading, and also the northern section of Humphreys Avenue, Nunawading.

The sections of discontinued road and pathway retained by Council are subject to the right, power and interest held by the Whitehorse City Council, Yarra Valley Water, Multinet Gas, NBN Co, Telstra, Optus and United Energy in or near the sections of discontinued road and pathway in connection with any sewers, drains, pipes, wires or cables under the control of those authorities in or near the sections of discontinued road and pathway.

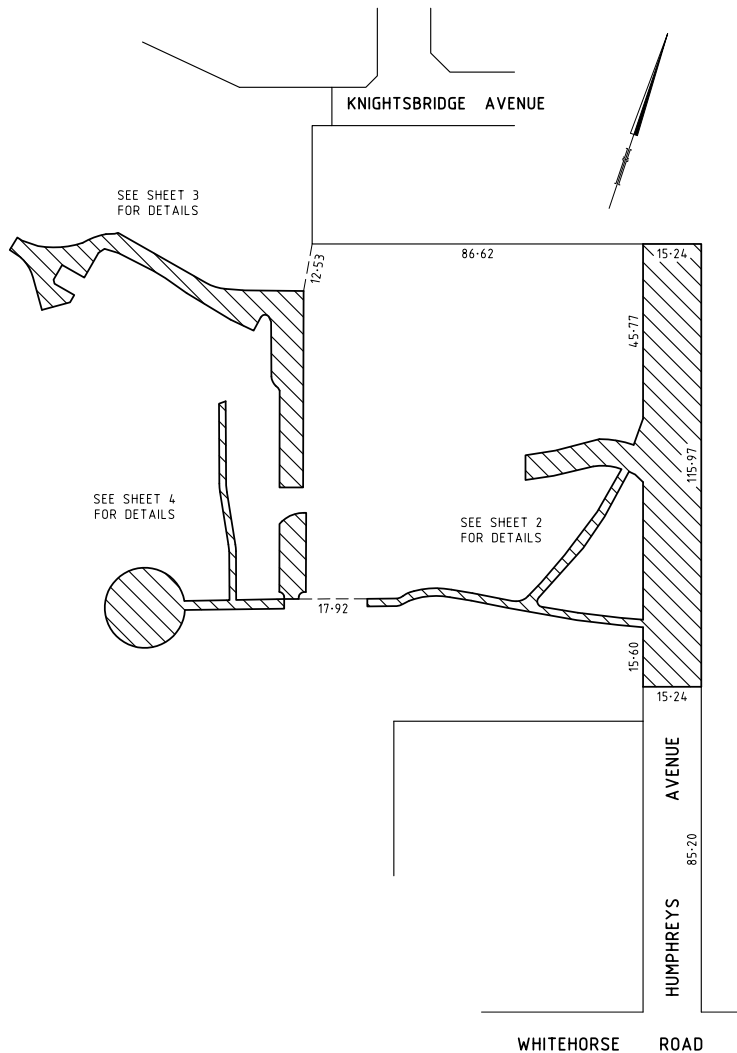

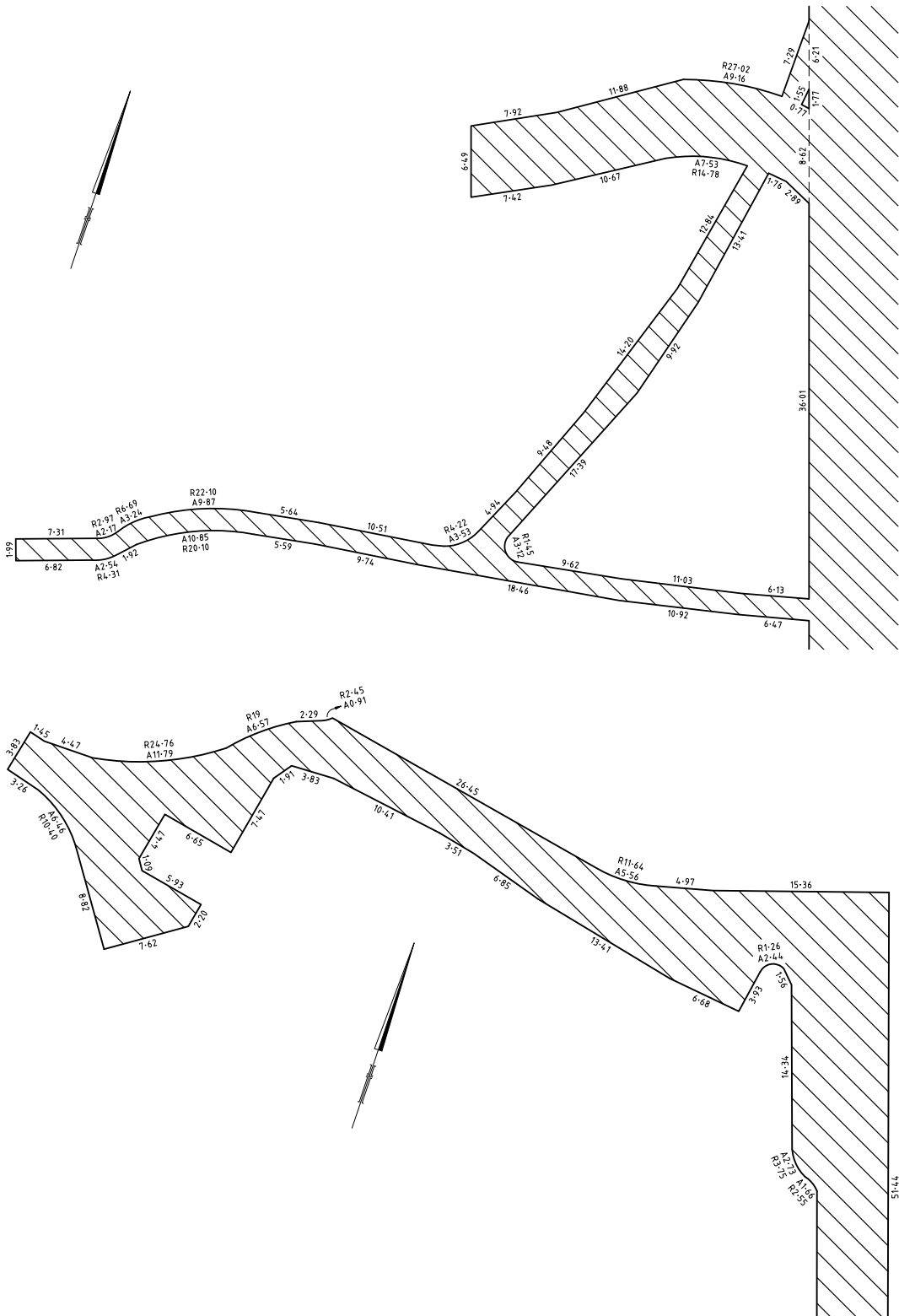

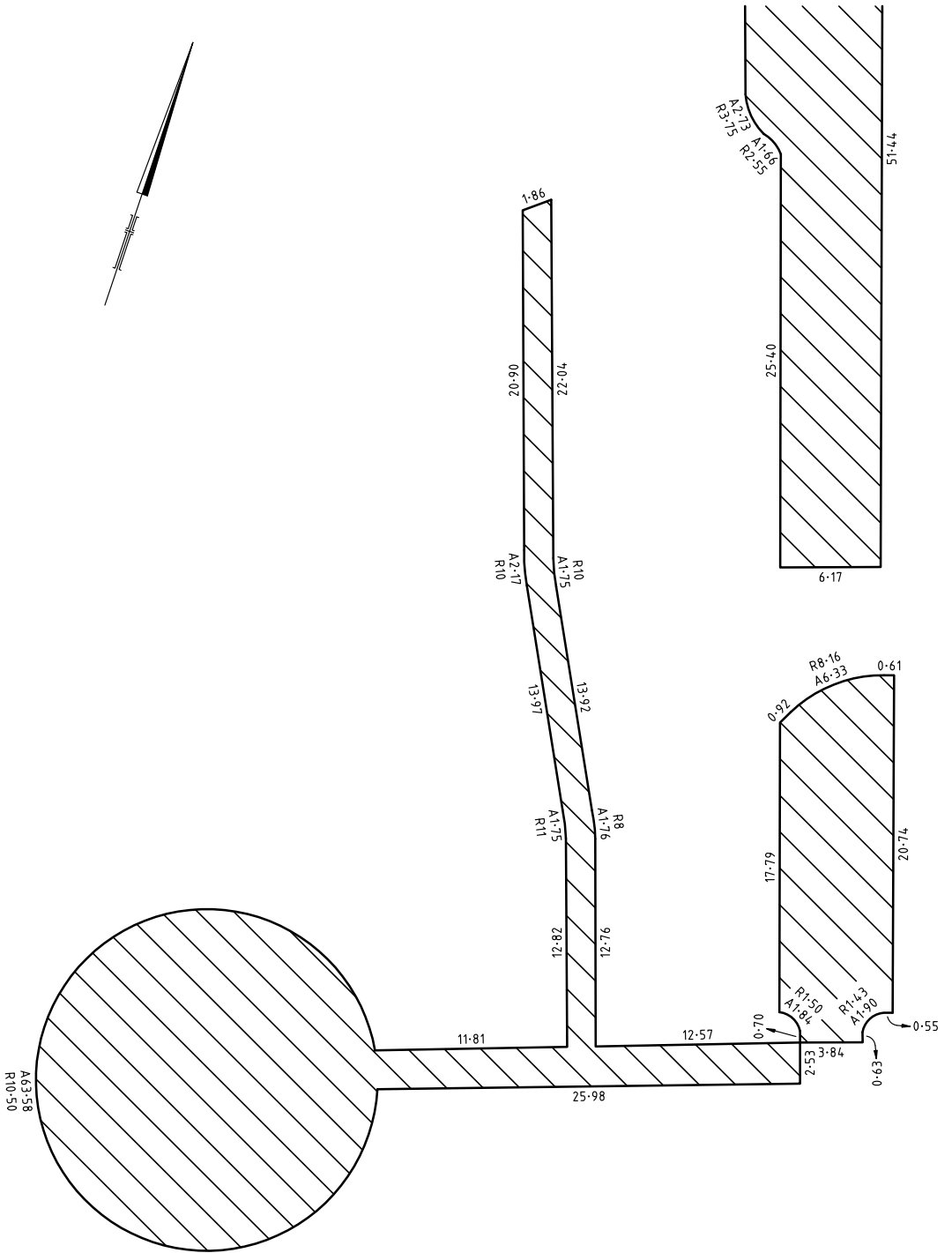

SIMON McMILLAN
Chief Executive Officer

ALPINE SHIRE COUNCIL

Notice of the Making of the
Governance Local Law (2020)

At the special council meeting on 25 August 2020, Alpine Shire Council resolved to make the Governance Local Law (2020), to come into operation on 1 September 2020.

In accordance with section 119(2) of the **Local Government Act 1989**, the objectives of the Local Law are to:

- Regulate the use of the Alpine Shire Council Common Seal;
- Provide for offences in relation to unauthorised use of the Common Seal or any device resembling the Common Seal; and
- Provide for offences in relation to Council meetings and Delegated Committee meetings.

A copy of the Governance Local Law (2020) is available on Council's website www.alpineshire.vic.gov.au. Hard copies may be inspected at the Bright Council Office, and Customer Service Centres / Libraries in Mount Beauty and Myrtleford once COVID-19 restrictions allow this. Interested persons may request a hard copy to be mailed to them, by contacting Council on (03) 5755 0555.

NOTICE OF MAKING OF MEETING
PROCEDURE LOCAL LAW 2020

Brimbank City Council, at its meeting on 18 August 2020, resolved to make the Meeting Procedure Local Law 2020, under section 111 of the **Local Government Act 1989**.

At its meeting on 18 August 2020, Council also resolved to revoke the Meeting Procedure Local Law No. 1 of 2015.

The Meeting Procedure Local Law 2020 replaces the Meeting Procedure Local Law No. 1 of 2015, and will operate throughout the municipal district of the City of Brimbank, from 1 September 2020.

**The objectives of the Meeting Procedure
Local Law 2020 are to:**

- Provide for the election of the Mayor and any Deputy Mayor.
- Provide for the appointment of any Acting Mayor.
- Provide for the procedures governing the conduct of Council Meetings, Delegated Committees and Community Asset Committees.

**The intended effect of the Meeting Procedure
Local Law 2020 is:**

- To ensure that Council adopts meeting procedures that are compliant with the Governance Principles in section 9 of the **Local Government Act 2020**.
- To ensure that any breach of the provisions in chapters 2, 3 and 4 of the Brimbank Governance Rules 2020, remains an offence under the Meeting Procedure Local Law 2020.

The Meeting Procedure Local Law 2020 is available on Council's website, www.brimbank.vic.gov.au

HELEN MORRISSEY
Chief Executive Officer

NOTICE OF MAKING A LOCAL LAW:
MEETING CONDUCT LOCAL LAW

Notice is given that at a meeting of Latrobe City Council (Council) held on 7 September 2020, Council resolved to adopt a new Local Law titled 'Local Law No. 1, Meeting Conduct Local Law' (Local Law) and incorporate the Governance Rules of Council.

Purpose of the Local Law

The purposes of the Local Law are to:

- regulate the use of the Council's common seal;
- prescribe enforcement measures in relation to procedures set out in the Governance Rules of Council governing the conduct of Council meetings, and Delegated Committee meetings and Community Asset Meetings where applicable.

General purport of the Local Law

The Local Law revokes Meeting Procedure Local Law No. 1 2017 and:

- Provides for the administration of Council's Common Seal;
- Creates offences for:
 - Misuse of Council's Common Seal;
 - Failure of a Councillor to withdraw an expression considered offensive or disorderly by the Chair;
 - Failure of a person who is not a Councillor to leave a meeting on the Chair's Order;
 - Failure of a Councillor to leave a meeting on the Chair's order or on Resolution of Council;
 - Failure of any person to comply with a lawful direction of the Chair at a meeting;
 - The fraudulent signing of a petition or joint letter which is presented to Council or has the intention of being presented to Council by any person;
 - Unauthorised recording or broadcasting of any part of a meeting.

Copies of the Local Law and Governance Rules may be obtained during office hours from: Latrobe City Council Headquarters, 141 Commercial Road, Morwell; Traralgon Service Centre, 34–38 Kay Street, Traralgon; Moe Service Centre, 1–29 George Street, Moe; Churchill Service Centre, 9–11 Philip Parade, Churchill (all by appointment only during COVID-19 restrictions); or may be viewed on Council's website, www.latrobe.vic.gov.au. To facilitate compliance with COVID-19 social distancing requirements, any person who wishes to obtain a hard copy is encouraged to request that it be posted to them. Requests can be made by phoning 1300 367 700.

The Local Law is to commence on the day after notice of the Local Law making appears in the Victoria Government Gazette.

STEVEN PIASENTE
Chief Executive Officer



GOVERNANCE LOCAL LAW 2, 2020

At its Scheduled Meeting on Wednesday 26 August 2020, Murrindindi Shire Council resolved to adopt the Governance Local Law 2, 2020. This is in accordance with sections 5, 91 and 111 of the **Local Government Act 1989** (now **Local Government Act 2020**).

The objectives of the Governance Local Law 2 are to:

- regulate the use of the Common Seal;
- prohibit unauthorised use of the Common Seal or any device resembling the Common Seal;
- provide for the penalties in relation to the conduct of Council Meetings and Delegated Committees.

The Governance Local Law 2, 2020 came into effect on 26 August 2020 and will expire on 26 August 2030 unless revoked earlier. Upon commencement of this Local Law, Council's Governance Local Law 2, 2014 is revoked.

A copy of the Local Law may be viewed online at murrindindi.vic.gov.au. All enquiries regarding the Governance Local Law 2, 2020 should be directed to Tara Carter, Manager Governance and Risk on (03) 5772 0333.



ADOPTED GOVERNANCE RULES

Notice is given that at a meeting held of the Strathbogrie Shire Council on 25 August 2020, the Council resolved to adopt Governance Rules under section 60 of the **Local Government Act 2020** (the Act).

Purpose of the Governance Rules:

The purpose of the Governance Rules is to:

- outline processes for Councillors, committee members and staff to declare conflicts of interest;
- provide for Council's Election (Caretaker) Period Policy;

- identify processes for the election of Mayor and (if required) Deputy Mayor and Chairs of Delegated Committees or Community Asset Committees;
- set out procedures for Council meetings, including the Audit and Risk Committee, any Delegated Committees and Community Asset Committees.

General purport of the Governance Rules:

Chapter 1 outlines processes to ensure orderly and inclusive Council meetings, which in turn support good governance and sound decision making. Community participation in Council meetings has been broadened to reinforce the importance of community input into our decision-making processes. The same meetings procedures apply to all Delegated Committees, Community Asset Committees and the Audit and Risk Committee unless otherwise resolved by Council. Procedures for the election of the Mayor and Deputy Mayor are also outlined in Chapter 1.

Conflicts of interest must be declared by Councillors, members of Committees and Council Staff (either providing advice to a Council or Committee meeting or making decisions under delegated powers). Chapter 2 sets out the process for transparently declaring these interests in accordance with the Act.

Chapter 3 deals with more informal meetings of Councillors and how records of those in attendance and a summary of the matters discussed at these meetings are to be made available to the public through the Council agenda and minutes. This chapter also deals with the classification of information as confidential by the Chief Executive Officer to ensure there is continuity with the 1989 Act.

The Election (Caretaker) Period Policy is outlined in Chapter 4 and is essentially the same as that adopted by Council in March 2020, with minor amendments to reflect the passing of the 2020 Act.

How can I get a copy of the Governance Rules?

Copies of the Governance Rules are available in hard copy from Council's Customer Service Centres at Euroa (109A Binney Street, Euroa) and Nagambie (293 High Street, Nagambie) during office hours.

An electronic copy can be found on Council's website, www.strathbogie.vic.gov.au. You can also request a hard or electronic copy of the document by calling our Customer Service team on 1800 065 993.

JULIE SALOMON
Chief Executive Officer



ADOPTION OF LOCAL LAW NO. 1 – USE OF THE COMMON SEAL 2020

Notice is given that, pursuant to section 119 of the **Local Government Act 1989** (the 1989 Act), at a meeting held of the Strathbogie Shire Council on 25 August 2020, the Council resolved to adopt Local Law No. 1 – Use of the Common Seal 2020.

The following information about the adopted Local Law is provided in accordance with section 119(2) of the 1989 Act:

Purpose of the Local Law:

The purpose of the Local Law is to:

- provide for continuity in regulation around the use of Council's Common Seal and to prohibit its unauthorised use; and
- repeal the existing Strathbogie Shire Council Meetings Procedures Local Law No. 1 of 2014, is being replaced by Governance Rules required under the **Local Government Act 2020** (the 2020 Act).

General purport of the Local Law:

The Local Law provides for the administration, storage and use of Council's Common Seal and repeals an existing local law that is required to be replaced by Governance Rules under the new 2020 Act. The Local Law creates an offence for the misuse of the Common Seal.

How can I get a copy of the Local Law?

Copies of the Local Law are available in hard copy from Council's Customer Service Centres at Euroa (109A Binney Street, Euroa) and Nagambie (293 High Street, Nagambie) during office hours.

An electronic copy can be found on Council's website www.strathbogie.vic.gov.au. You may also request a hard or electronic copy by calling our Customer Service Team on 1800 065 993.

JULIE SALOMON
Chief Executive Officer



Planning and Environment Act 1987
BAW BAW SHIRE PLANNING SCHEME
 Notice of the Preparation of an Amendment
 – Amended Notice
 Amendment C139

Baw Baw Shire Council has prepared Amendment C139 to the Baw Baw Shire Planning Scheme.

The entire Baw Baw Shire is affected by the Amendment.

The Amendment proposes to:

- replace the Municipal Strategic Statement and the Local Planning Policy Framework at Clause 21 and Clause 22 of the Baw Baw Shire Planning Scheme with a Municipal Planning Strategy and Planning Policy Framework;
- implement the recommendations of reports that underpin the Planning in the Economic Growth Zone project;
- update several schedules to the zones, overlays, and operational provisions to be consistent with the Ministerial Direction on Form and Content;
- revise several zones and overlay schedules to remove low risk permit triggers, introduce permit exemptions, and improve wording and efficacy of the provisions.

You may inspect the Amendment, any documents that support the Amendment and the explanatory report about the Amendment, free of charge, at: the Baw Baw Shire Council website at www.bawbawshire.vic.gov.au/Plan-and-Build/Planning-Scheme-Amendments/Current-Amendments/; during office hours, at the office of the planning authority, Baw Baw Shire Council, 33 Young Street, Drouin, Victoria 3818. Please note, this option is dependent on COVID-19 restrictions at the time and is subject to change; at the Department of Environment, Land, Water and Planning website, www.delwp.vic.gov.au/public-inspection

Any person who may be affected by the Amendment may make a submission to the planning authority about the Amendment. Submissions must be made in writing giving the submitter's name and contact address, clearly stating the grounds on which the Amendment is supported or opposed and indicating what changes (if any) the submitter wishes to make.

Name and contact details of submitters are required for Council to consider submissions and to notify such persons of the opportunity to attend Council meetings and any public hearing held to consider submissions.

Amendment C139 will be on exhibition until Friday 20 November 2020. However, you will not be able to view the Amendment or make a submission between Tuesday 22 September and Monday 26 October, due to pending Council elections.

A submission must be sent to Baw Baw Shire Council, PO Box 304, Warragul, Victoria 3820; or via email to Strategic.Planning@bawbawshire.vic.gov.au (Please mention 'Planning Scheme Amendment C139' in the subject line).

The planning authority must make a copy of every submission available at its office and/or on its website for any person to inspect, free of charge, for two months after the Amendment comes into operation or lapses.

Creditors, next-of-kin and others having claims against the estate of any of the undermentioned deceased persons are required to send particulars of their claims to State Trustees Limited, ABN 68 064 593 148, of 1 McNab Avenue, Footscray, Victoria 3011, the personal representative, on or before 17 November 2020, after which date State Trustees Limited may convey or distribute the assets, having regard only to the claims of which State Trustees Limited then has notice.

CADIEN, Kim Elizabeth Beverly, late of 4/12 Kiewa Avenue, Red Cliffs, Victoria 3496, deceased, who died on 9 July 2020.

FENSOM, Stanley Arthur, late of Bupa Coburg, 24 Sutherland Street, Coburg, Victoria 3058, deceased, who died on 12 April 2020.

GILLAN, Walter James, late of Kirrak House, 55 Baillieu Street West, Wonthaggi, Victoria 3995, pensioner, deceased, who died on 16 May 2020.

SALERMAN, Harold, late of Estia Aged Care, 6A Perrett Street, Grovedale, Victoria 3216, retired, deceased, who died on 31 July 2020.

SIMPSON, Dawn Loraine, late of 97 Hume Street, Corowa, New South Wales 2646, deceased, who died on 31 January 2020.

SPELLER, Ellen Ann, late of Bupa Aged Care Edithvale, 256–260 Station Street, Edithvale, Victoria 3196, retired, deceased, who died on 3 February 2020. Date of Grant 7 September 2020.

Dated 8 September 2020

Creditors, next-of-kin and others having claims against the estate of any of the undermentioned deceased persons are required to send particulars of their claims to State Trustees Limited, ABN 68 064 593 148, of 1 McNab Avenue, Footscray, Victoria 3011, the personal representative, on or before 19 November 2020, after which date State Trustees Limited may convey or distribute the assets, having regard only to the claims of which State Trustees Limited then has notice.

EVANS, Michael John, late of 123 Manningham Street, Parkville, Victoria 3052, deceased, who died on 23 April 2019.

JACKSON, Bevan Thomas, late of Cumberland View, 123–127 Whalley Drive, Wheelers Hill, Victoria 3150, deceased, who died on 15 July 2019.

MELLON, Albert Scott, late of Unit 4, 4A Colonsay Road, Springvale, Victoria 3171, deceased, who died on 23 May 2020.

NIELSEN, Monique, late of Unit 3, 8 Widdop Crescent, Hampton East, Victoria 3188, deceased, who died on 15 March 2020.

SAUNDERS, Patricia Ann, late of Opal Care, 79 Harnham Drive, Bairnsdale, Victoria 3875, deceased, who died on 15 May 2020.

SPITERI, Paul, late of Unit 7, 8 Sydney Street, Albion, Victoria 3020, deceased, who died on 22 April 2020.

Dated 10 September 2020

Cemeteries and Crematoria Act 2003

SECTION 41(1)

Notice of Approval of Cemetery Trust Fees and Charges

I, Bryan Crampton, as Delegate of the Secretary to the Department of Health and Human Services for the purposes of section 40(2) of the **Cemeteries and Crematoria Act 2003**, give notice that I have approved the scales of fees and charges fixed by the following cemetery trusts.

The approved scales of fees and charges will take effect from the date of publication of this notice in the Victoria Government Gazette and will be published on the internet.

The fees will be published on the internet at <http://www.health.vic.gov.au/cemeteries>

The Castlemaine Cemetery Trust

Dated 14 September 2020

BRYAN CRAMPTON

Manager

Cemetery Sector Governance Support Program

Corrections Act 1986

NOTICE OF AN AWARD OF DAMAGES TO A PRISONER

In accordance with section 104Y of the **Corrections Act 1986** notice is given that an award of damages has been made to former prisoner Christopher Bentley in a claim against the State of Victoria. The award money, excluding legal costs and medical expenses, has been paid into the Prisoner Compensation Quarantine Fund, where it will be held for an initial period of 12 months from 17 September 2020.

Creditors and victims in relation to criminal acts of Christopher Bentley are invited to seek further information from the Secretary to the Department of Justice and Community Safety. To do so, please contact the Co-ordinator, Victims Register and Prisoner Compensation Quarantine Fund, at Victim Services, Support and Reform on 1800-819-817.

Dated 17 September 2020

Corrections Act 1986

NOTICE OF AN AWARD OF DAMAGES TO A PRISONER

In accordance with section 104Y of the **Corrections Act 1986** notice is given that an award of damages has been made to former prisoner Richard Bowden in a claim against the State of Victoria. The award money, excluding legal costs and medical expenses, has been paid into the Prisoner Compensation Quarantine Fund, where it will be held for an initial period of 12 months from 17 September 2020.

Creditors and victims in relation to criminal acts of Richard Bowden are invited to seek further information from the Secretary to the Department of Justice and Community Safety. To do so, please contact the Co-ordinator, Victims Register and Prisoner Compensation Quarantine Fund, at Victim Services, Support and Reform on 1800-819-817.

Dated 17 September 2020

Crown Land (Reserves) Act 1978

ORDER GIVING APPROVAL TO GRANT A LICENCE UNDER SECTIONS 17B AND 17DA

Under section 17B and 17DA of the **Crown Land (Reserves) Act 1978**, I, Lily D'Ambrosio MP, Minister for Energy, Environment and Climate Change, being satisfied that there are special reasons which make the granting of a licence reasonable and appropriate in the particular circumstances and to do this will not be substantially detrimental to the use and enjoyment of any adjacent land reserved under the **Crown Land (Reserves) Act 1978**, approve the granting of a licence by the Melbourne City Council as committee of management over the Alexandra Gardens Reserve described in the schedule below for the purpose of the facilitation of a community focused culturally significant event that celebrates Melbourne's LGBTQIA+ communities in accordance with section 17B(3)(a) of the **Crown Land (Reserves) Act 1978**, state that:

- there are special reasons which make granting of a licence reasonable and appropriate in the particular circumstances; and
- to do this will not be substantially detrimental to the use and enjoyment of any adjacent land reserved under the **Crown Land (Reserves) Act 1978**.

SCHEDULE

The land, being the land shown hatched on the attached plans, which is part of the Crown land temporarily reserved for the purposes of ornamental plantation by Order in Council of 17 February 1981, published in the Government Gazette at 25 February 1981, page 577.

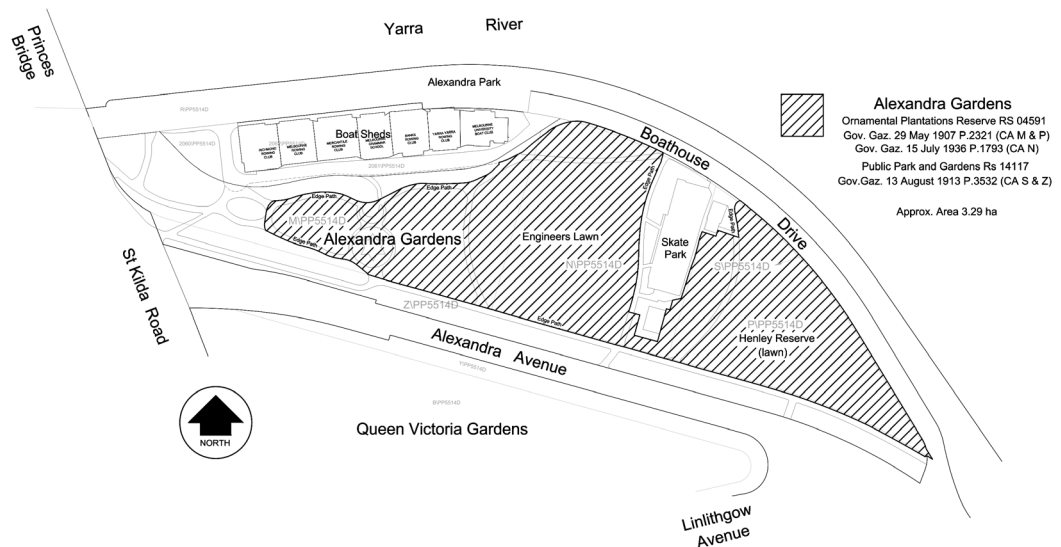

1204636

Dated 11 September 2020

LILY D'AMBROSIO MP
Minister for Energy, Environment and Climate Change

Crown Land (Reserves) Act 1978

ORDER GIVING APPROVAL TO GRANT A LEASE UNDER SECTIONS 17D AND 17DA

Under section 17D and 17DA of the **Crown Land (Reserves) Act 1978**, I, Lily D’Ambrosio MP, Minister for Energy, Environment and Climate Change, being satisfied that there are special reasons which make the granting of a lease reasonable and appropriate in the particular circumstances and to do this will not be substantially detrimental to the use and enjoyment of any adjacent land reserved under the **Crown Land (Reserves) Act 1978**, approve the granting of a lease by the Melbourne City Council as committee of management over the Royal Park Reserve described in the schedule below for the purpose of an urban camp and associated activities providing low cost accommodation for school and community groups and sporting organisation purposes and, in accordance with section 17D(3)(a) of the **Crown Land (Reserves) Act 1978**, state that:

- (a) there are special reasons which make granting of a lease reasonable and appropriate in the particular circumstances; and
- (b) to do this will not be substantially detrimental to the use and enjoyment of any adjacent land reserved under the **Crown Land (Reserves) Act 1978**.

SCHEDULE

The land shown hatched on the attached plan, which is part of the Crown land permanently reserved for the purposes of public park by Order in Council dated 20 November 1876, published in the Government Gazette at 24 November 1876, page 2158.

PLAN

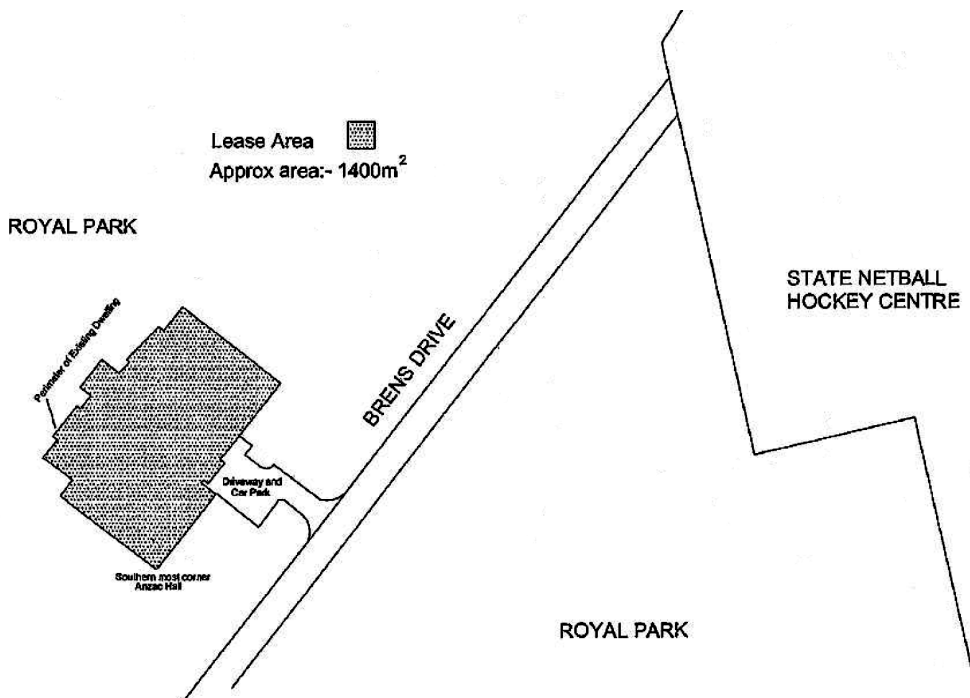

1204333
Dated 30 August 2020

LILY D’AMBROSIO MP
Minister for Energy, Environment and Climate Change

Education and Training Reform Act 2006

Pursuant to section 2.6.29(1)(b) of the **Education and Training Reform Act 2006** ('the Act'), all registrations held by a person under Part 2.6 of the Act are cancelled if the person has been given a negative notice within the meaning of the **Working With Children Act 2005**.

Pursuant to section 2.6.29(3) of the Act, a person whose registration is cancelled by the operation of section 2.6.29(1)(b) is disqualified from teaching in a school or early childhood service and is not entitled to apply to be registered under Part 2.6 of the Act for a period of 5 years after the date on which the negative notice is given. The disqualification from making an application to be registered under Part 2.6 of the Act does not apply if the negative notice is subsequently set aside or an assessment notice under the **Working with Children Act 2005** is subsequently given.

On 26 August 2020, Working with Children Check Victoria confirmed that Dalan John Oldaker was given a negative notice within the meaning of the **Working with Children Act 2005**.

On 7 September 2020, Dalan John Oldaker, a 44 year old male, ceased to be registered as a teacher and was disqualified from teaching in a school or early childhood service.

Electoral Act 2002

CHANGE TO REGISTER OF POLITICAL PARTIES

In accordance with section 51(5)(e) of the **Electoral Act 2002** (the Act), I hereby give notice of the following change to the Register of Political Parties.

Name of registered political party: Liberal Democratic Party.

New registered officer: Tim Quilty.

New address: Level 6, 40 City Road, Southbank, Victoria 3006.

Dated 8 September 2020

WARWICK GATELY, AM
Victorian Electoral Commission

Essential Services Commission Act 2001

ESSENTIAL SERVICES COMMISSION

Notice of determination: taxi non-cash payment surcharge

The Essential Services Commission has amended a determination on the maximum non-cash payment surcharge for taxis. Taxis are allowed to collect a surcharge from passengers who pay using debit card, credit card and other forms of non-cash payment.

The determination sets the maximum surcharge at:

- four per cent (including GST) for all non-cash payment methods except commercial passenger vehicle specific payment instruments and
- six per cent (no GST payable) for commercial passenger vehicle specific payment instruments (such as Cabcharge payment instruments).

The determination will now take effect from Monday 1 February 2021.

View the determination at www.esc.vic.gov.au

The commission has published this notice of the determination in accordance with section 35 of the **Essential Services Commission Act 2001**.

Health Complaints Act 2016

Section 90

INTERIM PROHIBITION ORDER

This Interim Prohibition Order is made pursuant to section 90 of the **Health Complaints Act 2016**.

The Health Complaints Commissioner (Commissioner) has made this Interim Prohibition Order because the Commissioner reasonably believes that the general health service provider named below has contravened a code of conduct applying to the general health service being provided and is satisfied that it is necessary to make this order to avoid a serious risk to the health, safety or welfare of the public.

Name of the general health service provider on whom the Interim Prohibition Order is imposed:	Brian Hickman of Wodonga in the State of Victoria
Date this Interim Prohibition Order is made:	2 September 2020
Date on which this Interim Prohibition Order expires:	An Interim Prohibition Order can remain in force for up to 12 weeks. This Interim Prohibition Order will remain in force until 24 November 2020 while an investigation is conducted unless it is varied or revoked before that date.
Effect of this Interim Prohibition Order:	<ol style="list-style-type: none"> 1. The general health service provider named above must not (either directly or indirectly): <ol style="list-style-type: none"> a. advertise or cause to be advertised, or b. offer or cause to be offered, or c. provide or cause to be provided any general health service (paid or otherwise, in a clinical or non-clinical capacity). 2. The general health service provider named above must not, directly or indirectly, provide or cause to be provided any professional supervision to other health service providers, in a formal or informal capacity, paid or otherwise. 3. The general health service provider named above must not operate any business that conducts any of the activities referred to in paragraphs 1 and 2 above. 4. The general health service provider named above must prominently display a copy of this Interim Prohibition Order at his business premises. 5. The general health service provider named above must publish a copy of this Interim Prohibition Order on any website he uses to offer or promote any general health service that he provides.

This Interim Prohibition Order takes effect on the service of the order on the general health service provider to whom it applies.

This Order will be published in the Victoria Government Gazette and on the internet site of the Health Complaints Commissioner, www.hcc.vic.gov.au

KAREN CUSACK
Health Complaints Commissioner

Health Services Act 1988

HEALTH PURCHASING VICTORIA

Notice of Purchasing Policy Exemption

Pursuant to section 134A of the **Health Services Act 1988**, Health Purchasing Victoria (HPV) now grants exemption to Mildura Base Public Hospital from the requirements specified at section 3 of HPV Health Purchasing Policy 1: Procurement Governance and subparagraph 2.4(d) of HPV Health Purchasing Policy 5: Collective Purchasing. This exemption supports the public hospital's transition to the HPV Health Purchasing Policies in which compliance monitoring and reporting requirements will commence on 17 September 2021.

This exemption becomes effective from the date of publication in the Government Gazette and ceases on 17 September 2021.

**West Gippsland
Libraries**

NOTICE OF INTENTION TO MAKE A LOCAL LAW –
MEETINGS PROCEDURE LOCAL LAW NO. 1 – 2020 AND
OPERATION AND USE OF LIBRARY SERVICES LOCAL LAW NO. 2 – 2020

Notice is given pursuant to section 119(3) of the **Local Government Act 1989** that West Gippsland Regional Library Corporation Board at its ordinary meeting held on 11 September 2020, resolved to invite public submissions in accordance with section 223 of the Act regarding its intention to make a new local law, Meetings Procedure Local Law No. 1 – 2020 and Operation and Use of Library Services Local Law No. 2 – 2020.

The purpose of this Local Law is to:

- facilitate good governance of the Library, its facilities and its Board;
- regulate proceedings for the election of the Chair;
- regulate proceedings at all Ordinary and Special Meetings of the Board and meetings of Special Committees;
- regulate the use of the Common Seal and Prohibit its unauthorised use;
- revoke Local Law No. 2 (Meetings Procedure and management of Libraries Local Law) 2008.

Copies of the proposed Local Law may be viewed online at www.wgrlc.vic.gov.au. If you are not able to access an electronic copy, please contact us for a request for a hard copy. Any person affected by this proposed Local Law may, pursuant to section 223 of the Act, lodge a formal written submission by Friday 6 November 2020 at 5.00 pm, to the Chief Executive Officer, West Gippsland Regional Library Corporation, 65 Victoria Street Warragul, Victoria 3820, or email ceo@wgrlc.vic.gov.au

Land Acquisition and Compensation Act 1986
FORM 7

S. 21(a)
 Reg. 16

Notice of Acquisition

Compulsory Acquisition of Interest in Land

Yarra Valley Water Corporation declares that by this notice it acquires the following interests in part of the land described in Certificate of Title Volume 11394 Folio 371 shown as Reserve No. 1 on the Plan of Subdivision PS836061S (Ref. 20354-SEC35-11) and in part of the land described in Certificate of Title Volume 11394 Folio 388 shown as Reserve No. 1 on the Plan of Subdivision PS839250X (Ref. 20345-SEC35-12).

Interests Acquired: The freehold interest of Deloraine Rural Pty Ltd (ACN 147 899 894) and all other interests.

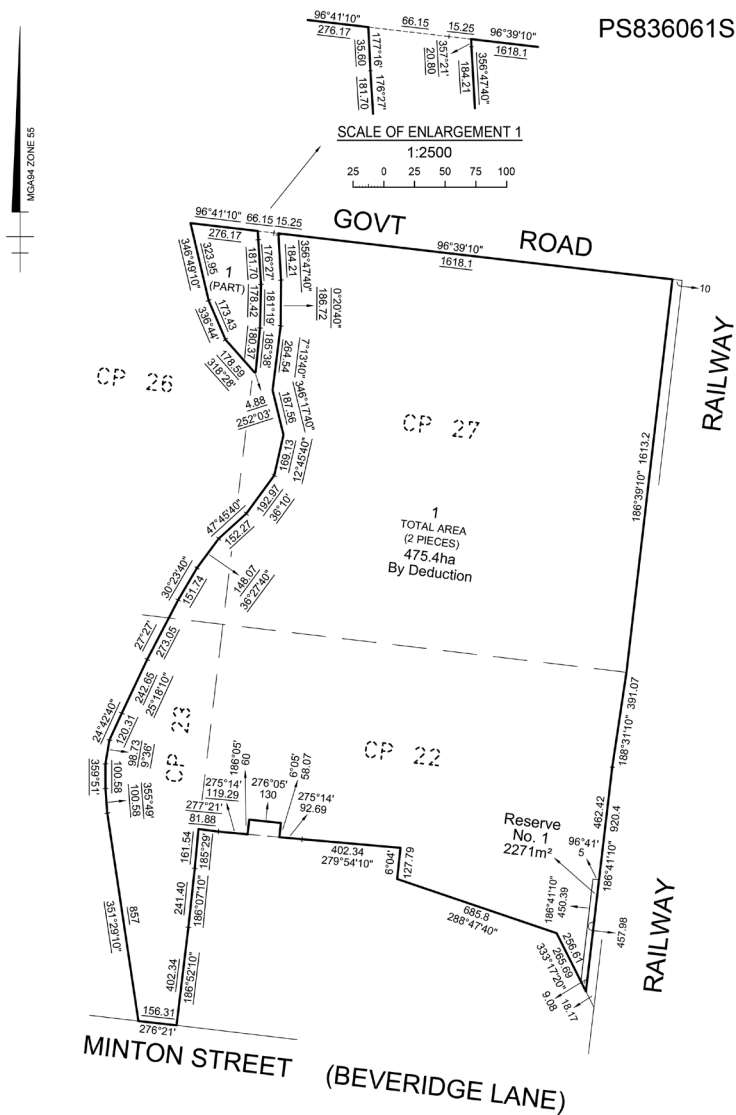

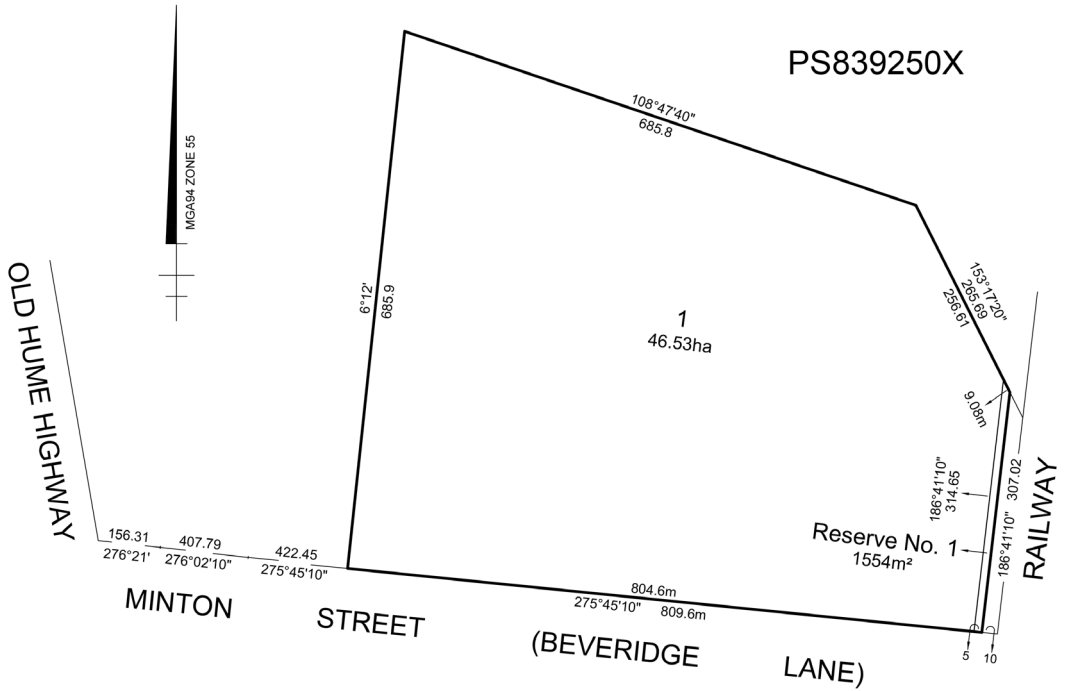

Published with the authority of Yarra Valley Water Corporation.
For and on behalf of Yarra Valley Water Corporation
Signed PAT McCafferty
Name Pat McCafferty, Managing Director
Dated 17 September 2020



Water Act 1989

NOTICE OF DECLARATION OF SERVICED PROPERTIES DECLARATION NO. 806

Central Highlands Water declares the properties as described below to be serviced properties for the purpose of the **Water Act 1989** on and from Thursday 17 September 2020.

PROPERTY	TOWNS	TYPE
PS818737L Lot 1 and 2	Ballan	water/sewer
PS840003J Lot 1 and 2	Ballarat North	water/sewer
PS832047H Lot 1 and 2	Buninyong	water/sewer
PS800291B Lot 1–4 incl.	Buninyong	water
PS820908W Lot 1–4 and 20–22 incl.	Canadian	water/sewer
PS829306D Lot 1 and 2	Cardigan	water
PS838380P Lot 1 and 2	Daylesford	water/sewer
PS836343G Lot 1–5 incl.	Delacombe	water/sewer
PS837480Q Lot 1 and 2	Hepburn Springs	water
PS738628L Lot 1	Learmonth	water/sewer
PS825909S Lot 5,1449 and 1414–1434 incl.	Lucas	water/sewer
PS825928N Lot 1 and 2	Maryborough	water/sewer
PS830208V Lot 2	Mitchell Park	water/sewer
PS830208V Lot 1	Mitchell Park	water/sewer
PS738311S Lot 1–4 incl.	Mount Clear	water/sewer
PS818522J Lot 1–4 incl.	Mount Pleasant	water/sewer
PS828002F Lot 1–22 incl.	Nerrina	water/sewer
PS839765M Lot 1 and 2	Smythes Creek	water/sewer
Crown Allotment 2 Section 89	Smythesdale	sewer
Crown Allotment 3 Section 6	Timor	water
PS835472A Lot 1 and 2	Wendouree	water/sewer
PS824621W Lot 697–724 incl.	Winter Valley	water/sewer

For more information contact Central Highlands Water on 1800 061 514.



East Gippsland Water

Water Act 1989

DECLARATION OF SERVICED PROPERTIES

In accordance with section 144 of the **Water Act 1989**, I advise that the following properties have been provided with Reticulated Services and are now liable to be rated as a serviced property for sewerage and/or water service purposes as from the following dates:

PROPERTY DESCRIPTION	PROPERTY ADDRESS	DATE	SERVICE
Lots 1–2 PS840654	Essington Close and Metung Road, Metung	03.08.2020	Water and Sewer
Lots 5–6 PS603381	Clara Street and Wattlebird Close, Kalimna	05.08.2020	Water and Sewer
PC379895	Curlew Grove, Metung	12.08.2020	Water and Sewer
Lots 3–4 PS824723	Merry Street and Bengworden Road, Bairnsdale	03.08.2020	Water
PC378239	Grevillea Avenue, Metung	18.08.2020	Water and Sewer
Lots 1–5 PS808287	Lanes Road, Lucknow	07.05.2020	Sewer
Lots 1–2 PS734369	Mathiesons Road, Eagle Point	21.08.2020	Water
Lots 1–2 PS835756	Ross Street, Lindenow	25.08.2020	Water and Sewer

A plan of the serviced properties is available by contacting the Corporation's office on 1800 671 841.

STEVE McKENZIE
Managing Director

Wildlife Act 1975

**REVOCATION OF THE PORT PHILLIP BAY WHALE (DOLPHIN)
SWIM TOUR LIMITED PERMIT AREA 2010**

I, James Todd, as delegate of the Secretary to the Department of Environment, Land, Water and Planning, revoke the Port Phillip Bay Whale (Dolphin) Swim Tour Limited Permit Area made on Friday 30 July 2010 in accordance with section 83GB of the **Wildlife Act 1975**.

Dated 16 April 2020

JAMES TODD
Executive Director, Biodiversity

Wildlife Act 1975**DETERMINATION OF THE PORT PHILLIP BAY WHALE (DOLPHIN)
SWIM TOUR LIMITED PERMIT AREA**

I, James Todd, as delegate of the Secretary to the Department of Environment, Land, Water and Planning, make the following determination under section 83F of the **Wildlife Act 1975**:

1. the area described in Schedule 1 is the Port Phillip Bay Whale (Dolphin) Swim Tour Limited Permit Area; and
2. the maximum number of whale swim tour permits to be granted in this area is four (4); and
3. 'dolphin' for the purposes of the determination means any wildlife that is a member of the family *Delphinidae* of the sub-order *Odontoceti* of the Order *Cetacea*, excluding *Orcinus orca* and members of the sub-family *Globicephalinae* (small toothed whales).

Dated 16 April 2020

JAMES TODD
Executive Director, Biodiversity

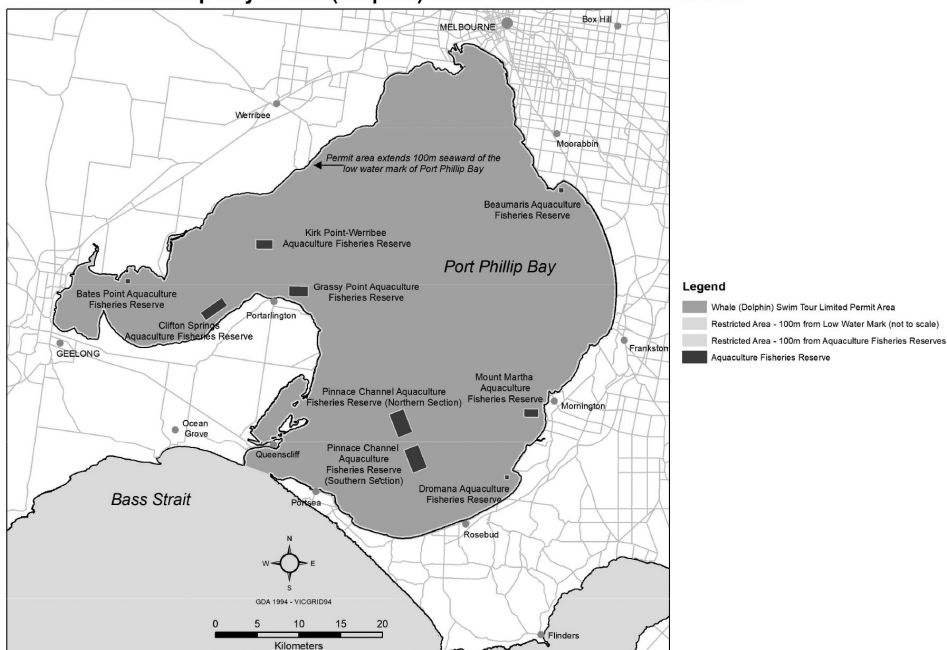
SCHEDULE 1**Port Phillip Bay Whale (Dolphin) Swim Tour Limited Permit Area**

All of the waters of Port Phillip Bay that are more than 100 m seaward of the low water mark of Port Phillip Bay, except the waters of the following areas that are declared as fisheries reserves for aquaculture purposes under section 88 of the **Fisheries Act 1975**, and the waters surrounding the following declared fisheries reserves to a distance of 100 m:

- Grassy Point Aquaculture Fisheries Reserve
- Clifton Springs Aquaculture Fisheries Reserve
- Kirk Point–Werribee Aquaculture Fisheries Reserve
- Bates Point Aquaculture Fisheries Reserve
- Beaumaris Aquaculture Fisheries Reserve
- Mount Martha Aquaculture Fisheries Reserve
- Dromana Aquaculture Fisheries Reserve
- Pinnacle Channel Aquaculture Fisheries Reserve.

Wildlife Act 1975**DETERMINATION OF THE PORT PHILLIP BAY WHALE (DOLPHIN) WATCHING (VESSEL) TOUR LIMITED PERMIT AREA**

I, James Todd, as delegate of the Secretary to the Department of Environment, Land, Water and Planning, make the following determination under section 83F of the **Wildlife Act 1975**:

1. the area described in Schedule 1 is the Port Phillip Bay Whale (Dolphin) Watching (Vessel) Tour Limited Permit Area; and
2. the maximum number of whale (dolphin) watching (vessel) tour permits to be granted in this area is zero (0); and
3. 'dolphin' for the purposes of the determination means any wildlife that is a member of the family *Delphinidae* of the sub-order *Odontoceti* of the Order *Cetacea*, excluding *Orcinus orca* and members of the sub-family *Globicephalinae* (small toothed whales).

Dated 16 April 2020

JAMES TODD
Executive Director, Biodiversity

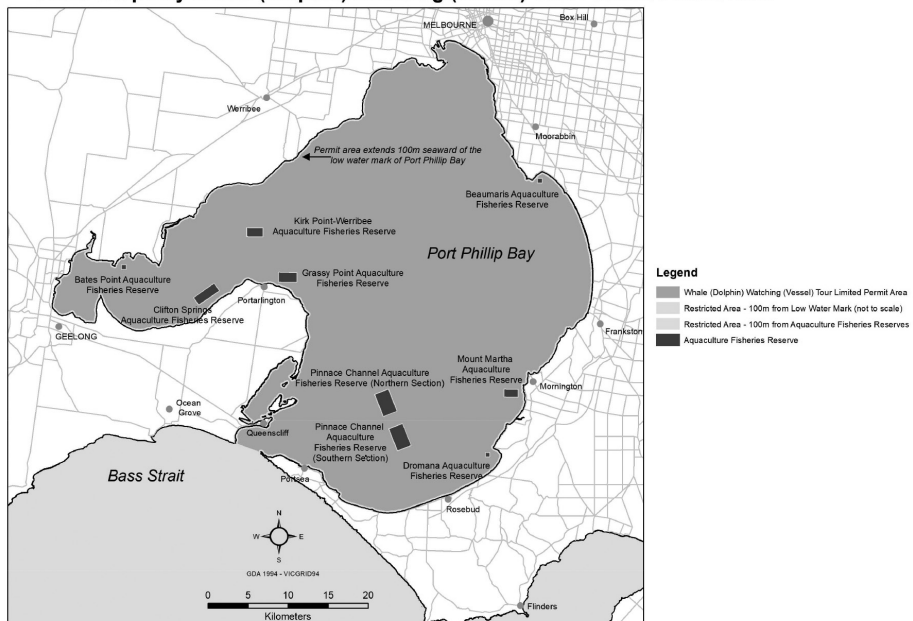
SCHEDULE 1**Port Phillip Bay Whale (Dolphin) Watching (Vessel) Tour Limited Permit Area**

All of the waters of Port Phillip Bay that are more than 100 m seaward of the low water mark of Port Phillip Bay, except the waters of the following areas that are declared as fisheries reserves for aquaculture purposes under section 88 of the **Fisheries Act 1975**, and the waters surrounding the following declared fisheries reserves to a distance of 100 m:

- Grassy Point Aquaculture Fisheries Reserve
- Clifton Springs Aquaculture Fisheries Reserve
- Kirk Point-Werribee Aquaculture Fisheries Reserve
- Bates Point Aquaculture Fisheries Reserve
- Beaumaris Aquaculture Fisheries Reserve
- Mount Martha Aquaculture Fisheries Reserve
- Dromana Aquaculture Fisheries Reserve
- Pinnacle Channel Aquaculture Fisheries Reserve.

Wildlife Act 1975**NOTICE OF DETERMINATION INVITING APPLICATIONS FOR THE
PORT PHILLIP BAY WHALE (DOLPHIN) SWIM TOUR LIMITED PERMIT AREA**

The Secretary to the Department of Environment, Land, Water and Planning, in accordance with section 83GC of the **Wildlife Act 1975**, gives notice that:

- i. The area described in Schedule 1 as the Port Phillip Bay Whale (Dolphin) Swim Tour Limited Permit Area (the Permit Area) was determined as a whale swim permit area and published in this Government Gazette on 17 September 2020;
- ii. The maximum number of whale (dolphin) swim tour permits available to be granted for the Permit Area is four (4);
- iii. Applications for whale swim tour permits are now invited and must be:
 - a. in the form called Whale (Dolphin) Swim Tour Application form, which can be obtained by contacting the Department of Environment, Land, Water and Planning on 136 186 or may be downloaded from www.wildlife.vic.gov.au; and
 - b. submitted via email to wildlifelicensing@delwp.vic.gov.au by no later than 2.00 pm on Thursday 8 October 2020; and
 - c. marked CONFIDENTIAL – Dolphin Swim Tour Permit Application;
- iv. Late and/or incomplete applications will not be considered;
- v. All applications will be assessed based on specific criteria as outlined in the Dolphin Swim Tour Permit Application Form;
- vi. Applicants seeking more information on the assessment criteria, and the rules and restrictions successful applicants must adhere to when operating dolphin swim tours under the permit, can be found in the Wildlife (Marine Mammal) Regulations 2019;
- vii. Note that additional permit conditions may be imposed;
- viii. Permits will be valid from 1 November 2020 to 30 June 2025; and
- ix. The fee for a whale swim tour permit is the fee prescribed in Regulation 32(3) of the Wildlife (Marine Mammal) Regulations 2019. The fee for the permit is \$8,213.

I, Wayne Robins, as delegate of the Secretary to the Department of Environment, Land, Water and Planning make this determination under section 83GC of the **Wildlife Act 1975**.

Dated 14 September 2020

WAYNE ROBINS
Director, Regulatory Strategy and Permissions

SCHEDULE 1

Port Phillip Bay Whale (Dolphin) Swim Tour Limited Permit Area

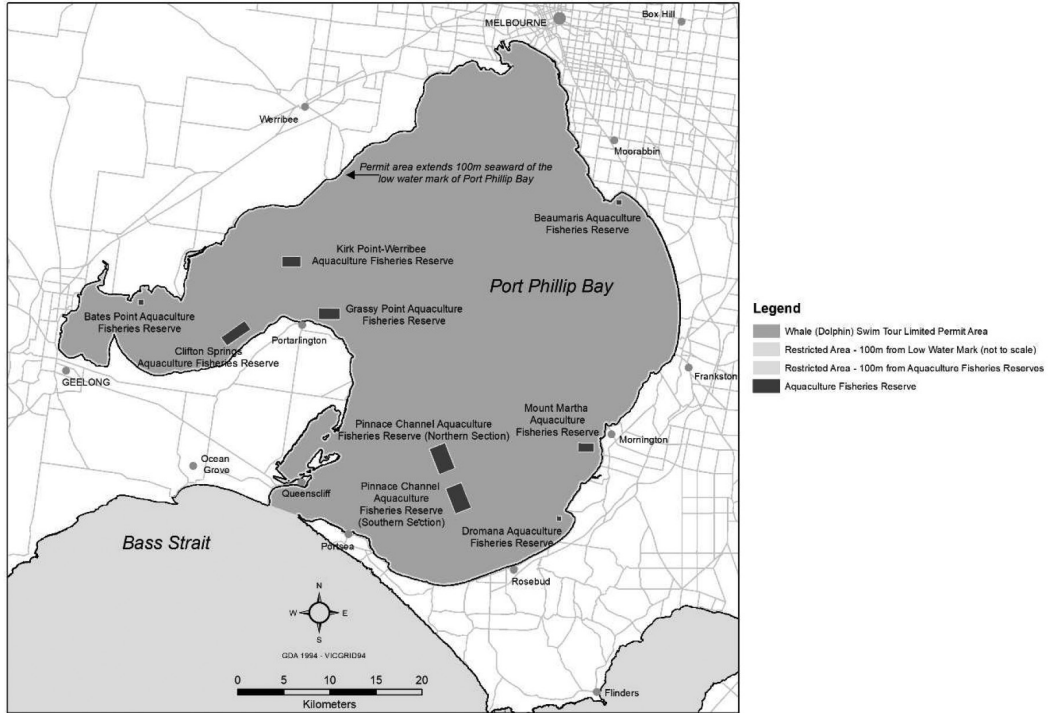

All of the waters of Port Phillip Bay that are more than 100 m seaward of the low water mark of Port Phillip Bay, except the waters of the following areas that are declared as fisheries reserves for aquaculture purposes under section 88 of the **Fisheries Act 1975**, and the waters surrounding the following declared fisheries reserves to a distance of 100 m:

- Grassy Point Aquaculture Fisheries Reserve
- Clifton Springs Aquaculture Fisheries Reserve
- Kirk Point-Werribee Aquaculture Fisheries Reserve
- Bates Point Aquaculture Fisheries Reserve
- Beaumaris Aquaculture Fisheries Reserve
- Mount Martha Aquaculture Fisheries Reserve
- Dromana Aquaculture Fisheries Reserve
- Pinnacle Channel Aquaculture Fisheries Reserve.

AGREEMENT FOR THE MELBOURNE CITY LINK AND AGREEMENT FOR THE
EXHIBITION STREET EXTENSION PROJECT

Notice under Schedule 4 of the Agreement for Integrating and Facilitating the Project and the Exhibition Street Extension Project between the Crown in right of the State of Victoria, CityLink Melbourne Limited, Transurban Infrastructure Management Limited and City Link Extension Pty Limited (the 'IFA') (as substituted for (and as if incorporated in lieu of) Schedule 3 of the Agreement for the Melbourne City Link between the Crown in right of the State of Victoria, CityLink Melbourne Limited and Transurban Infrastructure Management Limited (the 'Concession Deed') and Schedule 1 of the Agreement for the Exhibition Street Extension Project between the Crown in right of the State of Victoria and City Link Extension Pty Limited ('the ESEP Deed')).

CityLink Melbourne Limited (ABN 65 070 810 678) (for itself and as agent of City Link Extension Pty Limited (ABN 40 082 058 615)) ('CityLink Melbourne') gives notice of the following Charge Tolls, Maximum Charge Tolls and Day Tolls for the Melbourne City Link and the Exhibition Street Extension:

Schedule of Charge Tolls, Maximum Charge Tolls and Day Tolls

Charge Tolls (\$/vehicle)

Category of Vehicle Tollable Section	Car (including a Taxi)	Light Commercial Vehicle	Heavy Commercial Vehicle – Day	Heavy Commercial Vehicle – Night	Motor Cycle
Tullamarine Freeway Upgrade, between Moreland Road and Brunswick Road	2.65	4.24	7.96	5.31	1.33
Western Link Section 1, between Racecourse Road and Dynon Road	2.65	4.24	7.96	5.31	1.33
Western Link Section 2, between Footscray Road and West Gate Freeway	3.32	5.31	9.95	6.64	1.66
Domain Tunnel and that part of the Southern Link leading into that Tunnel between the eastern portal of that Tunnel and Punt Road, other than that part of Southern Link Section 1: (a) between Punt Road and the exit to Boulton Parade; and (b) comprising Boulton Parade	3.32	5.31	9.95	6.64	1.66
Burnley Tunnel and that part of the Southern Link leading out of that Tunnel between the eastern portal of that Tunnel and Burnley Street	5.97	9.55	17.91	11.94	2.98
Southern Link Section 1, between Burnley Street and Punt Road and including that part of Southern Link Section 1: (a) between Punt Road and the exit to Boulton Parade; and (b) comprising Boulton Parade	2.65	4.24	7.96	5.31	1.33
Southern Link Section 5, between Punt Road and Burnley Street other than that part of the Southern Link leading out of the Burnley Tunnel between the eastern portal of that Tunnel and Burnley Street	2.65	4.24	7.96	5.31	1.33
Southern Link Section 1, between Glenferrie Road and Burnley Street	2.65	4.24	7.96	5.31	1.33
Southern Link Section 5, between Burnley Street and Glenferrie Road	2.65	4.24	7.96	5.31	1.33
Exhibition Street Extension	1.66	2.65	4.98	3.32	0.83

Southern Link Section 1, between Punt Road and Swan Street Intersection, other than: (a) that part of Southern Link Section 1: (i) between Punt Road and the exit to Boulton Parade; and (ii) comprising Boulton Parade; and (b) that part of the Southern Link leading into the Domain Tunnel between the eastern portal of that Tunnel and Punt Road	1.66	2.65	4.98	3.32	0.83
Southern Link Section 5, between Swan Street Intersection and Punt Road	1.66	2.65	4.98	3.32	0.83

Notes:

1. When travelling on Southern Link Section 1 between Burnley Street and Punt Road and then onto Batman Avenue, the Tollable Sections may be combined for the purposes of levying Tolls.
2. When travelling on Southern Link Section 1 and into the Domain Tunnel, the Tollable Sections may be combined for the purposes of levying Tolls.
3. A reference in the description of a Tollable Section to a part of the Southern Link between a particular street or road and Burnley Street, includes that part of the Southern Link between that particular street or road and where Burnley Street would cross the Southern Link if Burnley Street continued in a straight southerly direction from its southernmost extremity.
4. In this table:
 - ‘Heavy Commercial Vehicle – Day’ refers to where the passage of the Heavy Commercial Vehicle on the Tollable Section occurs between 6.00 am and 8.00 pm.
 - ‘Heavy Commercial Vehicle – Night’ refers to where the passage of the Heavy Commercial Vehicle on the Tollable Section occurs between 8.00 pm and 6.00 am.
 - ‘Boulton Parade’ includes the off-ramp connecting the rest of the Southern Link to Boulton Parade;
 - ‘Burnley Tunnel’ means the eastbound tunnel between Sturt Street and Burnley Street;
 - ‘Domain Tunnel’ means the westbound tunnel between Punt Road and Sturt Street; and
 - ‘Swan Street Intersection’ means the intersection between Swan Street and Batman Avenue.

Maximum Charge Tolls (\$/vehicle)

Category of Vehicle	Car (including a Taxi)	Light Commercial Vehicle	Heavy Commercial Vehicle	Motor Cycle
Trips where the passage of the Vehicle on the last Tollable Section comprising the Trip before exiting the Total Link occurs between 6.00 am and 8.00 pm	9.95	15.92	29.85	4.98
Trips where the passage of the Vehicle on the last Tollable Section comprising the Trip before exiting the Total Link occurs between 8.00 pm and 6.00 am	9.95	15.92	19.90	4.98

Day Tolls (\$/vehicle)

Category of Vehicle	Car (including a Taxi)	Light Commercial Vehicle	Heavy Commercial Vehicle	Motor Cycle
Day Toll	19.08	41.40	77.12	9.54

CityLink Melbourne intends that each Charge Toll, Maximum Charge Toll, and Day Toll specified above will first apply in the quarter ending 31 December 2020.

Capitalised terms in this notice that are defined in:

- (a) the Concession Deed have, subject to paragraph (b), that meaning in this notice;
- (b) the ESEP Deed have that meaning in this notice, but only to the extent that the provision applies to the ESEP Deed,

subject to the provisions of the IFA.

FIONA LAST
Company Secretary
CityLink Melbourne Limited
(ABN 65 070 810 678)

HENRY BYRNE
Director
CityLink Melbourne Limited
(ABN 65 070 810 678)

AGREEMENT FOR THE EXHIBITION STREET EXTENSION PROJECT

Notice under Schedule 1 of the Agreement for the Exhibition Street Extension Project between the Crown in right of the State of Victoria and City Link Extension Pty Limited (the 'ESEP Deed').

City Link Extension Pty Limited (ABN 40 082 058 615) ('Clepc') gives notice of the following Charge Tolls for the Exhibition Street Extension:

Charge Tolls (\$/vehicle)

Category of Vehicle	Car (including a Taxi)	Light Commercial Vehicle	Heavy Commercial Vehicle – Day	Heavy Commercial Vehicle – Night	Motor Cycle
Tollable Section					
Exhibition Street Extension	1.66	2.65	4.98	3.32	0.83

Note:

In this table:

'Heavy Commercial Vehicle – Day' refers to where the passage of the Heavy Commercial Vehicle on the Tollable Section occurs between 6.00 am and 8.00 pm.

'Heavy Commercial Vehicle – Night' refers to where the passage of the Heavy Commercial Vehicle on the Tollable Section occurs between 8.00 pm and 6.00 am.

Clepc intends that these Charge Tolls will first apply in the quarter ending 31 December 2020.

Capitalised terms in this notice that are defined in the ESEP Deed have the same meaning as given by the ESEP Deed.

FIONA LAST
Company Secretary
City Link Extension Pty Limited
ABN 40 082 058 615

HENRY BYRNE
Director
City Link Extension Pty Limited
ABN 40 082 058 615

AGREEMENT FOR THE MELBOURNE CITY LINK

Notice under Schedule 3 of the Agreement for the Melbourne City Link between the Crown in right of the State of Victoria, CityLink Melbourne Limited and Transurban Infrastructure Management Limited (the 'Concession Deed').

CityLink Melbourne Limited (ABN 65 070 810 678) ('CityLink Melbourne') gives notice of the following Charge Tolls, Maximum Charge Tolls, and Day Tolls for the Melbourne City Link:

Charge Tolls (\$/vehicle)

Category of Vehicle Tollable Section	Car (including a Taxi)	Light Commercial Vehicle	Heavy Commercial Vehicle – Day	Heavy Commercial Vehicle – Night	Motor Cycle
Tullamarine Freeway Upgrade, between Moreland Road and Brunswick Road	2.65	4.24	7.96	5.31	1.33
Western Link Section 1, between Racecourse Road and Dynon Road	2.65	4.24	7.96	5.31	1.33
Western Link Section 2, between Footscray Road and West Gate Freeway	3.32	5.31	9.95	6.64	1.66
Domain Tunnel and that part of the Southern Link leading into that Tunnel between the eastern portal of that Tunnel and Punt Road, other than that part of Southern Link Section 1:	3.32	5.31	9.95	6.64	1.66
(a) between Punt Road and the exit to Boulton Parade; and					
(b) comprising Boulton Parade					
Burnley Tunnel and that part of the Southern Link leading out of that Tunnel between the eastern portal of that Tunnel and Burnley Street	5.97	9.55	17.91	11.94	2.98
Southern Link Section 1, between Burnley Street and Punt Road and including that part of Southern Link Section 1:	2.65	4.24	7.96	5.31	1.33
(a) between Punt Road and the exit to Boulton Parade; and					
(b) comprising Boulton Parade					

Southern Link Section 5, between Punt Road and Burnley Street other than that part of the Southern Link leading out of the Burnley Tunnel between the eastern portal of that Tunnel and Burnley Street	2.65	4.24	7.96	5.31	1.33
Southern Link Section 1, between Glenferrie Road and Burnley Street	2.65	4.24	7.96	5.31	1.33
Southern Link Section 5, between Burnley Street and Glenferrie Road	2.65	4.24	7.96	5.31	1.33
Southern Link Section 1, between Punt Road and Swan Street Intersection, other than: (a) that part of Southern Link Section 1: (i) between Punt Road and the exit to Boulton Parade; and (ii) comprising Boulton Parade; and (b) that part of the Southern Link leading into the Domain Tunnel between the eastern portal of that Tunnel and Punt Road	1.66	2.65	4.98	3.32	0.83
Southern Link Section 5, between Swan Street Intersection and Punt Road	1.66	2.65	4.98	3.32	0.83

Notes:

- When travelling on Southern Link Section 1 between Burnley Street and Punt Road and then onto Batman Avenue, the Tollable Sections may be combined for the purposes of levying Tolls.
- When travelling on Southern Link Section 1 and into the Domain Tunnel, the Tollable Sections may be combined for the purposes of levying Tolls.
- A reference in the description of a Tollable Section to a part of the Southern Link between a particular street or road and Burnley Street, includes that part of the Southern Link between that particular street or road and where Burnley Street would cross the Southern Link if Burnley Street continued in a straight southerly direction from its southernmost extremity.
- In this table:
 - ‘Heavy Commercial Vehicle – Day’ refers to where the passage of the Heavy Commercial Vehicle on the Tollable Section occurs between 6.00 am and 8.00 pm.
 - ‘Heavy Commercial Vehicle – Night’ refers to where the passage of the Heavy Commercial Vehicle on the Tollable Section occurs between 8.00 pm and 6.00 am.
 - ‘Boulton Parade’ includes the off-ramp connecting the rest of the Southern Link to Boulton Parade;
 - ‘Burnley Tunnel’ means the eastbound tunnel between Sturt Street and Burnley Street;
 - ‘Domain Tunnel’ means the westbound tunnel between Punt Road and Sturt Street; and
 - ‘Swan Street Intersection’ means the intersection between Swan Street and Batman Avenue.

Maximum Charge Tolls (\$/vehicle)

Category of Vehicle	Car (including a Taxi)	Light Commercial Vehicle	Heavy Commercial Vehicle	Motor Cycle
Trips where the passage of the Vehicle on the last Tollable Section comprising the Trip before exiting the Link occurs between 6.00 am and 8.00 pm	9.95	15.92	29.85	4.98
Trips where the passage of the Vehicle on the last Tollable Section comprising the Trip before exiting the Link occurs between 8.00 pm and 6.00 am	9.95	15.92	19.90	4.98

Day Tolls (\$/vehicle)

Category of Vehicle	Car (including a Taxi)	Light Commercial Vehicle	Heavy Commercial Vehicle	Motor Cycle
Day Toll	19.09	41.40	77.12	9.54

CityLink Melbourne intends that each Charge Toll, Maximum Charge Toll, and Day Toll specified above will first apply in the quarter ending 31 December 2020.

Capitalised terms in this notice that are defined in the Concession Deed have the same meaning as given by the Concession Deed.

FIONA LAST
Company Secretary
CityLink Melbourne Limited
(ABN 65 070 810 678)

HENRY BYRNE
Director
CityLink Melbourne Limited
(ABN 65 070 810 678)

Melbourne City Link Act 1995

NOTICE UNDER SECTION 71(1)

Under section 71(1)(b) of the **Melbourne City Link Act 1995** ('the Act'), CityLink Melbourne Limited ABN 65 070 810 678 (the relevant corporation in relation to the Link road) hereby fixes tolls which are payable in respect of the use of vehicles (as set out herein) on toll zones on the Link road.

For the purposes of this Notice, the following definitions apply:

Boulton Parade includes the off-ramp connecting the rest of the Link road to Boulton Parade;

Burnley Tunnel means the eastbound tunnel between Sturt Street and Burnley Street;

Bus is a Motor Vehicle having more than 12 seating positions (including that of the driver);

Car:

- (a) is a Motor Vehicle, other than a Motor Cycle, a Light Commercial Vehicle or a Heavy Commercial Vehicle, even if such a Motor Vehicle is towing a trailer or caravan; and
- (b) notwithstanding paragraph (a), includes all Taxis, irrespective of vehicle classification.

Domain Tunnel means the westbound tunnel between Punt Road and Sturt Street;

Extension road has the same meaning as in the Act;

Full Link road is the road included within both the Link road and the Extension road;

HCV – Day refers to where the passage of the Heavy Commercial Vehicle on the toll zone occurs between 6.00 am and 8.00 pm.

HCV – Night refers to where the passage of the Heavy Commercial Vehicle on the toll zone occurs between 8.00 pm and 6.00 am.

Heavy Commercial Vehicle or **HCV** is a Motor Vehicle, other than a Taxi, which is:

- (a) a rigid Truck with three or more axles;
- (b) an articulated Truck;
- (c) a Bus; or
- (d) a two-axle rigid Truck having a gross vehicle mass which exceeds 4.5 tonnes;

Light Commercial Vehicle or **LCV** is a Motor Vehicle, other than a Taxi, which is a two-axle rigid Truck having a gross vehicle mass which exceeds 1.5 tonnes, but does not exceed 4.5 tonnes;

Link road has the same meaning as in the Act;

Motor Cycle is a two-wheeled Motor Vehicle (and includes such a Motor Vehicle even if it has a trailer, fore car or side car attached) other than a Taxi;

Motor Vehicle is a vehicle which is used or intended to be used on a highway or in a public place and which has its own motive power (other than human or animal power) but does not include:

- (a) a vehicle intended to be used on a railway or tramway; or
- (b) a motorised wheelchair capable of a speed of not more than 10 kilometres per hour which is used solely for the conveyance of an injured or disabled person;

Swan Street Intersection means the intersection between Swan Street and Batman Avenue;

Taxi is, at any particular time, a Motor Vehicle in relation to which a commercial passenger vehicle licence (issued under the **Transport Act 1983**) then subsists, being a licence allowing for the operation of the Motor Vehicle as a Taxi-Cab (within the meaning of the **Transport Act 1983**);

the Agreement has the same meaning as in the Act;

the Integration and Facilitation Agreement has the same meaning as in the Act;

toll zone has the same meaning as in the Act;

Trip is the passage of a vehicle on one or more toll zones:

- (a) uninterrupted by exit and subsequent re-entry; or

- (b) if so interrupted, the interruption consists only of travel directly between:
- (i) that part of the Link road between Bulla Road and the West Gate Freeway; and
 - (ii) that part of the Link road between Sturt Street and Glenferrie Road;

Truck is a Motor Vehicle other than a Bus which has a cab-chassis construction and a gross vehicle mass which exceeds 1.5 tonnes; and

vehicle has the same meaning as in the Act.

Under section 71(1)(b) of the Act and in accordance with the Agreement, the tolls listed in Table One are payable in respect of the use of vehicles on toll zones on the Link road, where those vehicles are a Car, a LCV, a HCV or a Motor Cycle:

Table One					
Toll Zone	Toll				
	Car (including a Taxi)	LCV	HCV – Day	HCV – Night	Motor Cycle
1. That part of the Link road between Moreland Road and Brunswick Road.	\$2.65	\$4.24	\$7.96	\$5.31	\$1.33
2. That part of the Link road between Racecourse Road and Dynon Road.	\$2.65	\$4.24	\$7.96	\$5.31	\$1.33
3. That part of the Link road between Footscray Road and the West Gate Freeway.	\$3.32	\$5.31	\$9.95	\$6.64	\$1.66
4. That part of the Link road being the Domain Tunnel and that part of the Link road leading into that Tunnel between the eastern portal of that Tunnel and Punt Road, other than that part of the Link road – (a) being the eastbound carriageways of the Link road; (b) between Punt Road and the exit to Boulton Parade; and (c) comprising Boulton Parade.	\$3.32	\$5.31	\$9.95	\$6.64	\$1.66
5. That part of the Link road being the Burnley Tunnel and that part of the Link road leading out of that Tunnel between the eastern portal of that Tunnel and Burnley Street.	\$5.97	\$9.55	\$17.91	\$11.94	\$2.98

6. That part of the Link road being the eastbound carriageways between Punt Road and Burnley Street other than that part of the Link road being the Burnley Tunnel and that part of the Link road leading out of that Tunnel between the eastern portal of that Tunnel and Burnley Street.	\$2.65	\$4.24	\$7.96	\$5.31	\$1.33
7. That part of the Link road between Burnley Street and Punt Road and including that part of the Link road – (a) between Punt Road and the exit to Boulton Parade, other than the eastbound carriageways; and (b) comprising Boulton Parade, other than: (i) the eastbound carriageways between Burnley Street and Punt Road; and (ii) that part of the Link road being the Burnley Tunnel and that part of the Link road leading out of that Tunnel between the eastern portal of that Tunnel and Burnley Street.	\$2.65	\$4.24	\$7.96	\$5.31	\$1.33
8. That part of the Link road being the eastbound carriageways between Burnley Street and Glenferrie Road.	\$2.65	\$4.24	\$7.96	\$5.31	\$1.33
9. That part of the Link road between Glenferrie Road and Burnley Street, other than the eastbound carriageways.	\$2.65	\$4.24	\$7.96	\$5.31	\$1.33
10. That part of the Link road being the eastbound carriageways between Swan Street Intersection and Punt Road, other than – (a) that part of the Link road being the Burnley Tunnel; and (b) that part of the Link road comprising Boulton Parade.	\$1.66	\$2.65	\$4.98	\$3.32	\$0.83

11. That part of the Link road between Punt Road and Swan Street Intersection, other than – (a) the eastbound carriageways; (b) that part of the Link road being the Burnley Tunnel; (c) that part of the Link road: (1) between Punt Road and the exit to Boulton Parade; and (2) comprising Boulton Parade; and (d) that part of the Link road being the Domain Tunnel and that part of the Link road leading into that Tunnel between the eastern portal of that Tunnel and Punt Road.	\$1.66	\$2.65	\$4.98	\$3.32	\$0.83
---	--------	--------	--------	--------	--------

For the avoidance of doubt, a reference in this Notice to the specification of a toll zone by reference to Burnley Street refers to that point on the Link road where Burnley Street would cross the Link road if Burnley Street continued in a straight southerly direction from its southernmost extremity. For the avoidance of doubt, a reference in this Notice to ‘eastbound’ means in a general easterly direction from the eastern end of the West Gate Freeway towards Glenferrie Road.

Notwithstanding anything to the contrary in Table One, under section 71(1) (b) of the Act and in accordance with the Agreement, the maximum tolls payable in respect of the use of a vehicle on a toll zone on the Link road where that vehicle is a Car, a LCV, a HCV or a Motor Cycle for a Trip are as listed in Table Two:

Trip Cap	Toll			
	Car (including a Taxi)	LCV	HCV	Motor Cycle
1. Where the passage of the vehicle on the last toll zone comprising the Trip before exiting the Full Link road occurs between 6 am and 8 pm on the same day.	\$9.95	\$15.92	\$29.85	\$4.98
2. Where the passage of the vehicle on the last toll zone comprising the Trip before exiting the Full Link road occurs between 8 pm on the one day and 6 am on the next.	\$9.95	\$15.92	\$19.90	\$4.98

For the avoidance of doubt, this Notice does not set Charge Tolls or Maximum Charge Tolls for the purposes of Schedule 3 (the Toll Calculation Schedule) of the Agreement, or Schedule 4 (the Toll Calculation Schedule) of the Integration and Facilitation Agreement.

For the avoidance of doubt, this Notice also:

- (i) revokes or repeals; or, in the alternative
- (ii) amends –

the NOTICE UNDER SECTION 71(1) dated 22 June 2020 and published in the Victoria Government Gazette No. S 298 (pages 9 to 13) dated 23 June 2020 ('the Last Notice').

This notice takes effect on 1 October 2020 and for the avoidance of doubt, the Last Notice ceases to have effect when this Notice takes effect, and the revocation, repeal, amendment or ceasing to have effect of the Last Notice shall not:

- (a) revive anything not in force or existing at the time at which the revocation, repeal, amendment or ceasing to have effect becomes operative;
- (b) affect the previous operation of the Last Notice or anything duly done or suffered under the Last Notice;
- (c) affect any right, privilege, obligation or liability acquired, accrued or incurred under the Last Notice;
- (d) affect any penalty, forfeiture or punishment incurred in respect of any offence committed relating (directly or indirectly) to or in respect of the Last Notice; or
- (e) affect any investigation, legal proceeding or remedy in respect of any such right, privilege, obligation, liability, penalty, forfeiture or punishment as is mentioned in paragraphs (c) and (d) –

and any such investigation, legal proceeding or remedy may be instituted, continued or enforced, and any such penalty, forfeiture or punishment may be imposed, as if the Last Notice had not been revoked or repealed or amended or had not expired, lapsed or otherwise ceased to have effect.

For the avoidance of doubt, the revocation, repeal, amendment or ceasing to have effect of the Last Notice does not in any way affect the direct amendments made in or by the Last Notice to, or the operation or effect of those amendments to, any NOTICE UNDER SECTION 71(1) published in the Victoria Government Gazette prior to the publication of the Last Notice.

Dated 16 September 2020

FIONA LAST
Company Secretary
CityLink Melbourne Limited
(ABN 65 070 810 678)

HENRY BYRNE
Director
CityLink Melbourne Limited
(ABN 65 070 810 678)

Melbourne City Link Act 1995
NOTICE UNDER SECTION 71(1)

Under section 71(1)(b) of the **Melbourne City Link Act 1995** ('the Act'), City Link Extension Pty Limited ABN 40 082 058 615 (the relevant corporation in relation to the Extension road) hereby fixes tolls which are payable in respect of the use of vehicles (as set out herein) on the toll zone on the Extension road.

For the purposes of this Notice, the following definitions apply:

Bus is a Motor Vehicle having more than 12 seating positions (including that of the driver);

Car:

- (a) is a Motor Vehicle, other than a Motor Cycle, a Light Commercial Vehicle or a Heavy Commercial Vehicle, even if such a Motor Vehicle is towing a trailer or caravan; and
- (b) notwithstanding paragraph (a), includes all Taxis, irrespective of vehicle classification.

Extension road has the same meaning as in the Act;

HCV – Day refers to where the passage of the Heavy Commercial Vehicle on the toll zone occurs between 6.00 am and 8.00 pm.

HCV – Night refers to where the passage of the Heavy Commercial Vehicle on the toll zone occurs between 8.00 pm and 6.00 am.

Heavy Commercial Vehicle or **HCV** is a Motor Vehicle, other than a Taxi, which is:

- (a) a rigid Truck with three or more axles;
- (b) an articulated Truck;
- (c) a Bus; or
- (d) a two-axle rigid Truck having a gross vehicle mass which exceeds 4.5 tonnes;

Light Commercial Vehicle or **LCV** is a Motor Vehicle, other than a Taxi, which is a two-axle rigid Truck having a gross vehicle mass which exceeds 1.5 tonnes, but does not exceed 4.5 tonnes;

Motor Cycle is a two-wheeled Motor Vehicle (and includes such a Motor Vehicle even if it has a trailer, fore car or side car attached) other than a Taxi;

Motor Vehicle is a vehicle which is used or intended to be used on a highway or in a public place and which has its own motive power (other than human or animal power) but does not include:

- (a) a vehicle intended to be used on a railway or tramway; or
- (b) a motorised wheelchair capable of a speed of not more than 10 kilometres per hour which is used solely for the conveyance of an injured or disabled person;

Taxi is, at any particular time, a Motor Vehicle in relation to which a commercial passenger vehicle licence (issued under the **Transport Act 1983**) then subsists, being a licence allowing for the operation of the Motor Vehicle as a Taxi-Cab (within the meaning of the **Transport Act 1983**);

the Extension Agreement has the same meaning as in the Act;

the Integration and Facilitation Agreement has the same meaning as in the Act;

toll zone has the same meaning as in the Act;

Truck is a Motor Vehicle other than a Bus which has a cab-chassis construction and a gross vehicle mass which exceeds 1.5 tonnes; and

vehicle has the same meaning as in the Act.

Under section 71(1)(b) of the Act and in accordance with the Extension Agreement, the tolls listed in Table One are payable in respect of the use of vehicles on the toll zone on the Extension road, where those vehicles are a Car, a LCV, a HCV or a Motor Cycle:

Table One					
Toll Zone	Toll				
	Car (including a Taxi)	LCV	HCV – Day	HCV – Night	Motor Cycle
12. The Extension road	\$1.66	\$2.65	\$4.98	\$3.32	\$0.83

For the avoidance of doubt, this Notice does not set Charge Tolls for the purposes of Schedule 1 (the Toll Calculation Schedule) of the Extension Agreement, or Schedule 4 (the Toll Calculation Schedule) of the Integration and Facilitation Agreement.

For the avoidance of doubt, this Notice also:

- (i) revokes or repeals; or, in the alternative
- (ii) amends –

the NOTICE UNDER SECTION 71(1) dated 22 June 2020 and published in the Victoria Government Gazette No. S 298 (pages 14 to 15) dated 23 June 2020 ('the Last Notice').

This notice takes effect on 1 October 2020 and for the avoidance of doubt, the Last Notice ceases to have effect when this Notice takes effect, and the revocation, repeal, amendment or ceasing to have effect of the Last Notice shall not:

- (a) revive anything not in force or existing at the time at which the revocation, repeal, amendment or ceasing to have effect becomes operative;
- (b) affect the previous operation of the Last Notice or anything duly done or suffered under the Last Notice;
- (c) affect any right, privilege, obligation or liability acquired, accrued or incurred under the Last Notice;
- (d) affect any penalty, forfeiture or punishment incurred in respect of any offence committed relating (directly or indirectly) to or in respect of the Last Notice; or
- (e) affect any investigation, legal proceeding or remedy in respect of any such right, privilege, obligation, liability, penalty, forfeiture or punishment as is mentioned in paragraphs (c) and (d) –

and any such investigation, legal proceeding or remedy may be instituted, continued or enforced, and any such penalty, forfeiture or punishment may be imposed, as if the Last Notice had not been revoked or repealed or amended or had not expired, lapsed or otherwise ceased to have effect.

For the avoidance of doubt, the revocation, repeal, amendment or ceasing to have effect of the Last Notice does not in any way affect the direct amendments made in or by the Last Notice to, or the operation or effect of those amendments to, any NOTICE UNDER SECTION 71(1) published in the Victoria Government Gazette prior to the publication of the Last Notice.

Dated 16 September 2020

FIONA LAST
Company Secretary
City Link Extension Pty Limited
(ABN 40 082 058 615)

HENRY BYRNE
Director
City Link Extension Pty Limited
(ABN 40 082 058 615)

Melbourne City Link Act 1995
NOTICE UNDER SECTION 71(1)

Under section 71(1)(b) of the **Melbourne City Link Act 1995** ('the Act'), CityLink Melbourne Limited ABN 65 070 810 678 (the relevant corporation in relation to the Link road) ('CityLink Melbourne') hereby fixes tolls which are payable in respect of the use of vehicles on toll zones on the Link road where those vehicles are the subject of a CityLink Pass for that use.

For the purposes of this Notice, the following definitions apply:

Bus is a Motor Vehicle having more than 12 seating positions (including that of the driver);

Car:

- (a) is a Motor Vehicle, other than a Motor Cycle, a Light Commercial Vehicle or a Heavy Commercial Vehicle, even if such a Motor Vehicle is towing a trailer or caravan; and
- (b) notwithstanding paragraph (a), includes all Taxis, irrespective of vehicle classification.

CityLink Pass is a 24 Hour Pass, a Tulla Pass or a Weekend Pass;

Extension road has the same meaning as in the Act;

Full Link road is the road included within both the Link road and the Extension road;

Heavy Commercial Vehicle or **HCV** is a Motor Vehicle, other than a Taxi, which is:

- (a) a rigid Truck with three or more axles;
- (b) an articulated Truck;
- (c) a Bus; or
- (d) a two-axle rigid Truck having a gross vehicle mass which exceeds 4.5 tonnes;

Light Commercial Vehicle or **LCV** is a Motor Vehicle, other than a Taxi, which is a two-axle rigid Truck having a gross vehicle mass which exceeds 1.5 tonnes, but does not exceed 4.5 tonnes;

Link road has the same meaning as in the Act;

Motor Cycle is a two-wheeled Motor Vehicle (and includes such a Motor Vehicle even if it has a trailer, fore car or side car attached) other than a Taxi;

Motor Vehicle is a vehicle which is used or intended to be used on a highway or in a public place and which has its own motive power (other than human or animal power) but does not include:

- (a) a vehicle intended to be used on a railway or tramway; or
- (b) a motorised wheel chair capable of a speed of not more than 10 kilometres per hour which is used solely for the conveyance of an injured or disabled person;

Taxi is, at any particular time, a Motor Vehicle in relation to which a commercial passenger vehicle licence (issued under the **Transport Act 1983**) then subsists, being a licence allowing for the operation of the Motor Vehicle as a Taxi-Cab (within the meaning of the **Transport Act 1983**);

the Agreement has the same meaning as in the Act;

the Integration and Facilitation Agreement has the same meaning as in the Act;

toll zone has the same meaning as in the Act;

Trip is the passage of a vehicle on one or more toll zones:

- (a) uninterrupted by exit and subsequent re-entry; or
- (b) if so interrupted, consists only of travel directly between:
 - (i) that part of the Link road between Bulla Road and the West Gate Freeway; and
 - (ii) that part of the Link road between Sturt Street and Glenferrie Road;

Truck is a Motor Vehicle other than a Bus which has a cab-chassis construction and a gross vehicle mass which exceeds 1.5 tonnes;

Tulla Pass is an agreement with CityLink Melbourne for CityLink Melbourne to register a Car, Light Commercial Vehicle or Motor Cycle under Part 4 of the Act for use only on that part of the Link road being the Tullamarine Freeway Upgrade, between Bulla Road and Flemington Road including the toll zone between Moreland Road and Brunswick Road, for a fixed 24-hour period commencing at the time of the first Tulla Trip by that Car, Light Commercial Vehicle or Motor Cycle on a specified day;

Tulla Trip is the passage of a Car, Light Commercial Vehicle or Motor Cycle on that part of the Link road being the toll zone between Moreland Road and Brunswick Road;

24 Hour Pass is an agreement with CityLink Melbourne to register a vehicle under Part 4 of the Act for use of any or all toll zones comprising the Full Link road for a fixed 24-hour period commencing at the time of the first Trip by the vehicle on a specified day;

vehicle has the same meaning as in the Act; and

Weekend Pass is an agreement with CityLink Melbourne to register a Car, Light Commercial Vehicle or Motor Cycle under Part 4 of the Act for use of any or all toll zones comprising the Full Link road for a fixed period commencing at 12.00 pm on the Friday immediately before a specified Saturday and ending at midnight on the Sunday immediately following that specified Saturday. The fact that CityLink Melbourne also registers a Car, Light Commercial Vehicle or Motor Cycle for an additional period at no extra charge does not prevent the agreement from being a Weekend Pass.

Under section 71(1)(b) of the Act and in accordance with the Agreement, the tolls listed in Table One are payable in respect of the use of vehicles on toll zones on the Link road where the vehicle is the subject of a 24 Hour Pass for that use.

Table One				
24 Hour Pass	Toll			
	Car (including a Taxi)	LCV	HCV	Motor Cycle
	19.09	41.40	77.12	9.54

Under section 71(1)(b) of the Act and in accordance with the Agreement, the tolls listed in Table Two are payable in respect of the use of vehicles on toll zones on the Link road where the vehicle is the subject of a Weekend Pass for that use.

Table Two			
Weekend Pass	Toll		
	Car (including a Taxi)	LCV	Motor Cycle
	19.09	41.40	9.54

Under section 71(1)(b) of the Act and in accordance with the Agreement, the tolls listed in Table Three are payable in respect of the use of Cars, Light Commercial Vehicles or Motor Cycles on the toll zone, consisting of that part of the Link road between Moreland Road and Brunswick Road, where the Car, Light Commercial Vehicle or Motor Cycle is the subject of a Tulla Pass for that use.

Table Three			
Tulla Pass	Toll		
	Car (including a Taxi)	LCV	Motor Cycle
	6.79	10.87	3.37

For the avoidance of doubt, this Notice does not set Charge Tolls or Day Tolls for the purpose of Schedule 3 (the Toll Calculation Schedule) of the Agreement or Schedule 4 (the Toll Calculation Schedule) of the Integration and Facilitation Agreement.

For the avoidance of doubt, this Notice also:

- (i) revokes or repeals; or, in the alternative
- (ii) amends –

the NOTICE UNDER SECTION 71(1) dated 22 June 2020 and published in the Victoria Government Gazette No. S 298 (pages 16 to 18) dated 23 June 2020 (‘the Last Notice’).

This notice takes effect on 1 October 2020 and for the avoidance of doubt, the Last Notice ceases to have effect when this Notice takes effect, and the revocation, repeal, amendment or ceasing to have effect of the Last Notice shall not:

- (a) revive anything not in force or existing at the time at which the revocation, repeal, amendment or ceasing to have effect becomes operative;
- (b) affect the previous operation of the Last Notice or anything duly done or suffered under the Last Notice;
- (c) affect any right, privilege, obligation or liability acquired, accrued or incurred under the Last Notice;
- (d) affect any penalty, forfeiture or punishment incurred in respect of any offence committed relating (directly or indirectly) to or in respect of the Last Notice; or
- (e) affect any investigation, legal proceeding or remedy in respect of any such right, privilege, obligation, liability, penalty, forfeiture or punishment as is mentioned in paragraphs (c) and (d) –

and any such investigation, legal proceeding or remedy may be instituted, continued or enforced, and any such penalty, forfeiture or punishment may be imposed, as if the Last Notice had not been revoked or repealed or amended or had not expired, lapsed or otherwise ceased to have effect.

For the avoidance of doubt, the revocation, repeal, amendment or ceasing to have effect of the Last Notice does not in any way affect the direct amendments made in or by the Last Notice to, or the operation or effect of those amendments to, any NOTICE UNDER SECTION 71(1) published in the Victoria Government Gazette prior to the publication of the Last Notice.

Dated 16 September 2020

FIONA LAST
Company Secretary
CityLink Melbourne Limited
(ABN 65 070 810 678)

HENRY BYRNE
Director
CityLink Melbourne Limited
(ABN 65 070 810 678)

Melbourne City Link Act 1995

NOTICE UNDER SECTION 71(1)

Under section 71(1)(b) of the **Melbourne City Link Act 1995** ('the Act'), City Link Extension Pty Limited ABN 40 082 058 615 (the relevant corporation in relation to the Extension road) hereby fixes tolls which are payable in respect of the use of vehicles on the toll zone on the Extension road where those vehicles are the subject of a CityLink Pass for that use.

For the purposes of this Notice, the following definitions apply:

Bus is a Motor Vehicle having more than 12 seating positions (including that of the driver);

Car:

- (a) is a Motor Vehicle, other than a Motor Cycle, a Light Commercial Vehicle or a Heavy Commercial Vehicle, even if such a Motor Vehicle is towing a trailer or caravan; and
- (b) notwithstanding paragraph (a), includes all Taxis, irrespective of vehicle classification.

CityLink is CityLink Melbourne Limited ABN 65 070 810 678, the relevant corporation for the purposes of section 73C of the Act;

CityLink Pass is a 24 Hour Pass or a Weekend Pass;

Extension road has the same meaning as in the Act;

Full Link road is the road included within both the Link road and the Extension road;

Heavy Commercial Vehicle or **HCV** is a Motor Vehicle, other than a Taxi, which is:

- (a) a rigid Truck with three or more axles;
- (b) an articulated Truck;
- (c) a Bus; or
- (d) a two-axle rigid Truck having a gross vehicle mass which exceeds 4.5 tonnes;

Light Commercial Vehicle or **LCV** is a Motor Vehicle, other than a Taxi, which is a two-axle rigid Truck having a gross vehicle mass which exceeds 1.5 tonnes, but does not exceed 4.5 tonnes;

Link road has the same meaning as in the Act;

Motor Cycle is a two-wheeled Motor Vehicle (and includes such a Motor Vehicle even if it has a trailer, fore car or side car attached) other than a Taxi;

Motor Vehicle is a vehicle which is used or intended to be used on a highway or in a public place and which has its own motive power (other than human or animal power) but does not include:

- (a) a vehicle intended to be used on a railway or tramway; or
- (b) a motorised wheelchair capable of a speed of not more than 10 kilometres per hour which is used solely for the conveyance of an injured or disabled person;

Taxi is, at any particular time, a Motor Vehicle in relation to which a commercial passenger vehicle licence (issued under the **Transport Act 1983**) then subsists, being a licence allowing for the operation of the Motor Vehicle as a Taxi-Cab (within the meaning of the **Transport Act 1983**);

the Extension Agreement has the same meaning as in the Act;

the Integration and Facilitation Agreement has the same meaning as in the Act;

toll zone has the same meaning as in the Act;

Trip is the passage of a vehicle on one or more toll zones:

- (a) uninterrupted by exit and subsequent re-entry; or
- (b) if so interrupted, consists only of travel directly between:
 - (i) that part of the Link road between Bulla Road and the West Gate Freeway; and
 - (ii) that part of the Link road between Sturt Street and Glenferrie Road;

Truck is a Motor Vehicle other than a Bus which has a cab-chassis construction and a gross vehicle mass which exceeds 1.5 tonnes;

24 Hour Pass is an agreement with CityLink to register a vehicle under Part 4 of the Act for use of any or all toll zones comprising the Full Link road for a fixed 24 hour period commencing at the time of the first Trip by the vehicle on a specified day;

vehicle has the same meaning as in the Act; and

Weekend Pass is an agreement with CityLink to register a Car, Light Commercial Vehicle or Motor Cycle under Part 4 of the Act for use of any or all toll zones comprising the Full Link road for a fixed period commencing at 12.00 pm on the Friday immediately before a specified Saturday and ending at midnight on the Sunday immediately following that specified Saturday. The fact that CityLink also registers that Car, Light Commercial Vehicle or Motor Cycle for an additional period at no extra charge does not prevent the agreement from being a Weekend Pass.

Under section 71(1)(b) of the Act and in accordance with the Extension Agreement, the tolls listed in Table One are payable in respect of the use of vehicles on the toll zone on the Extension road where the vehicle is the subject of a 24 Hour Pass for that use.

Table One				
24 Hour Pass	Toll			
	Car (including a Taxi)	LCV	HCV	Motor Cycle
	19.09	41.40	77.12	9.54

Under section 71(1)(b) of the Act and in accordance with the Extension Agreement, the tolls listed in Table Two are payable in respect of the use of vehicles on the toll zone on the Extension road where the vehicle is the subject of a Weekend Pass for that use.

Table Two			
Weekend Pass	Toll		
	Car (including a Taxi)	LCV	Motor Cycle
	19.09	41.40	9.54

For the avoidance of doubt, this Notice does not set Charge Tolls or Day Tolls for the purpose of Schedule 1 (the Toll Calculation Schedule) of the Extension Agreement or Schedule 4 (the Toll Calculation Schedule) of the Integration and Facilitation Agreement.

For the avoidance of doubt, this Notice also:

- (i) revokes or repeals; or, in the alternative
- (ii) amends –

the NOTICE UNDER SECTION 71(1) dated 22 June 2020 and published in the Victoria Government Gazette No. S 298 (pages 19 to 21) dated 23 June 2020 ('the Last Notice').

This notice takes effect on 1 October 2020 and for the avoidance of doubt, the Last Notice ceases to have effect when this Notice takes effect, and the revocation, repeal, amendment or ceasing to have effect of the Last Notice shall not:

- (a) revive anything not in force or existing at the time at which the revocation, repeal, amendment or ceasing to have effect becomes operative;
- (b) affect the previous operation of the Last Notice or anything duly done or suffered under the Last Notice;
- (c) affect any right, privilege, obligation or liability acquired, accrued or incurred under the Last Notice;
- (d) affect any penalty, forfeiture or punishment incurred in respect of any offence committed relating (directly or indirectly) to or in respect of the Last Notice; or

- (e) affect any investigation, legal proceeding or remedy in respect of any such right, privilege, obligation, liability, penalty, forfeiture or punishment as is mentioned in paragraphs (c) and (d) –

and any such investigation, legal proceeding or remedy may be instituted, continued or enforced, and any such penalty, forfeiture or punishment may be imposed, as if the Last Notice had not been revoked or repealed or amended or had not expired, lapsed or otherwise ceased to have effect.

For the avoidance of doubt, the revocation, repeal, amendment or ceasing to have effect of the Last Notice does not in any way affect the direct amendments made in or by the Last Notice to, or the operation or effect of those amendments to, any NOTICE UNDER SECTION 71(1) published in the Victoria Government Gazette prior to the publication of the Last Notice.

Dated 16 September 2020

FIONA LAST
Company Secretary
City Link Extension Pty Limited
(ABN 40 082 058 615)

HENRY BYRNE
Director
City Link Extension Pty Limited
(ABN 40 082 058 615)

Major Transport Projects Facilitation Act 2009
NOTICE OF DECISION TO DISCONTINUE PART OF ROAD
 Portion of Grange Road, Caulfield East

Under section 186 of the **Major Transport Projects Facilitation Act 2009** (Act), I, Kevin Devlin, Chief Executive Officer, Level Crossing Removal Project, as delegate of the project authority for the Caulfield Dandenong Rail Upgrade Project (Project), give notice of my decision to discontinue the part of the road as shown shaded on the below plan GP24007A for the purposes of the Project.

This decision takes effect upon publication of this notice under section 189(1) of the Act, and the land is taken to be unalienated land of the Crown freed and discharged from all trusts, limitations, reservations, restrictions, encumbrances, estates and interests.

If you have any questions or would like more information, please phone our Community Information Line on 1800 105 105 or contact us via email at contact@levelcrossings.vic.gov.au

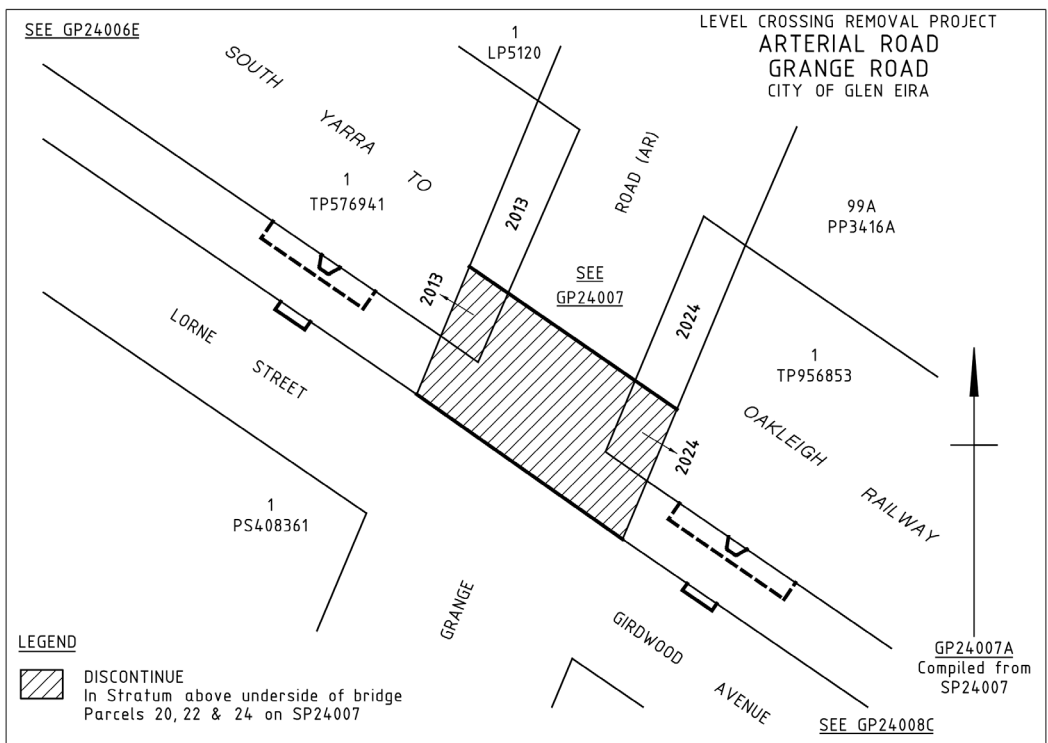

KEVIN DEVLIN
 Chief Executive Officer
 Level Crossing Removal Project

**Major Transport Projects Facilitation Act 2009, Transport Integration Act 2010 and
Land Acquisition and Compensation Act 1986**

INSTRUMENT OF DELEGATION BY SECRETARY

CHILDS ROAD UPGRADE

I, Paul Younis, Secretary to the Department of Transport (**Secretary**) as project authority of the Childs Road Upgrade project (**Project**), a declared project for which designation of the project area in accordance with Part 4 of the **Major Transport Projects Facilitation Act 2009** (Vic.) (**MTPF Act**) occurred on 27 March 2020, and as project authority being also:

- taken to be specified as a determining referral authority in the Whittlesea Planning Scheme under the **Planning and Environment Act 1987** (Vic.) (**Planning and Environment Act 1987**) by operation of section 102A of the MTPF Act (**determining referral authority**); and
- the Authority for the purpose of the **Land Acquisition and Compensation Act 1986** (Vic.) (**LACA**) as applied by section 113 of the MTPF Act (**Authority**) –

in exercise of the powers vested in me under section 104 of the MTPF Act, section 39 of the **Transport Integration Act 2010** and any and all other enabling powers, hereby delegate to the person(s) from time to time employed within the Department of Transport (**DOT**) (which includes the Major Transport Infrastructure Authority, the administrative office existing in relation to DOT that is responsible for delivery of the Project (**MTIA**) and occupying the positions specified in Column 3 of the Schedule to this instrument (each a **Delegate**) such of:

- the project functions and powers conferred on me under the MTPF Act in respect of the Project;
- my powers, duties and functions as determining referral authority in relation to land in the project area; and
- my powers and functions as the Authority –

as are specified for the Delegate in Column 1 and summarised in Column 2 of the Schedule to this instrument, subject to the following conditions and limitations:

1. any condition or limitation that is specified in Column 4 of the Schedule to this instrument with respect to a power, duty or function that is specified in Column 1 of the Schedule to this instrument; and
2. the condition that the power, duty or function may only be exercised for the purpose of the Project.

If the Delegate considers that a project function is one that, in the particular circumstances, requires referral to the Secretary, then before exercising the project function the Delegate should inform and consult with the Secretary.

In the interpretation of this instrument, the summary of a provision set out in Column 2 of the Schedule to this instrument is for convenience only and, unless a contrary intention appears, does not amend, substitute or delete any part of a provision of the MTPF Act or LACA set out in Column 1 of the Schedule to this instrument or otherwise affect the scope or effect of the power, duty or function delegated.

A Delegate is not authorised to delegate or sub-delegate any power delegated under this instrument.

This delegation will remain valid until it is revoked.

The delegation I signed on 23 April 2020 delegating to persons employed within DOT certain powers, duties and functions in respect of the Project, is hereby revoked.

Dated 2 September 2020

PAUL YOUNIS
Secretary to the Department of Transport

SCHEDULE

MTPF Act			
Column 1 MTPF Act Provision	Column 2 Summary of Provision	Column 3 Delegates	Column 4 Conditions or Limitations
Section 96	The project authority may request the Planning Minister to vary the project area for the approved project.	<ul style="list-style-type: none"> • Director General, MTIA • Chief Executive Officer, Major Road Projects Victoria (MRPV) • Director, Commercial & Legal, MRPV 	
Section 101	<p>The project authority may exercise the project authority's functions, summarised as follows:</p> <ul style="list-style-type: none"> • section 101(a): facilitating development of the approved project; • sections 101(b), (c): evaluating submissions from and negotiating with interested parties; • sections 101(d), (e), (f): making recommendations in relation to, and entering and administering contractual arrangements for, development or delivery of the approved project; • sections 101(g), (h), (i): facilitating and coordinating consultations, and negotiating and entering into arrangements, and coordinating, with statutory authorities, agencies of the State and other bodies or persons involved in, or affected by, development or operation of the approved project; • section 101(i): making recommendations to the Project Minister in relation to facilitating the approved project; • section 101(j): ensuring that agreements and arrangements between the State and any other person for, or relating to, the development or delivery of the approved project are performed in accordance with their terms; • section 101(k): commissioning transport infrastructure that is developed as part of the approved project; • section 101(l): undertaking any other functions conferred on the project authority under the MTPF Act or any other Act. 	<ul style="list-style-type: none"> • Director General, MTIA • Chief Executive Officer, MRPV • Director, Commercial & Legal, MRPV <p>and the following class of positions:</p> <ul style="list-style-type: none"> • Director, Delivery, MRPV 	

MTPF Act			
Column 1 MTPF Act Provision	Column 2 Summary of Provision	Column 3 Delegates	Column 4 Conditions or Limitations
Section 102	<p>For the purpose of performing its functions, and in addition to all other powers conferred on it by or under any other Act or law, exercising:</p> <ul style="list-style-type: none"> • section 102(1): a specified project power or power conferred on it by or under the MTPF Act; and • Section 102(2): do all other things necessary or convenient to be done for, or in connection with, or as incidental to, the performance of project functions under the MTPF Act. 	<ul style="list-style-type: none"> • Director General, MTIA • Chief Executive Officer, MRPV • Director, Commercial & Legal, MRPV • Director, Transport Property, DOT <p>and the following class of positions:</p> <ul style="list-style-type: none"> • Director, Delivery, MRPV 	
Section 102A	<p>The project authority for an approved project is taken to be specified as a determining referral authority in any planning scheme under the Planning and Environment Act.</p>	<ul style="list-style-type: none"> • Director General, MTIA • Chief Executive Officer, MRPV • Director, Commercial and Legal, MRPV <p>and the following class of positions:</p> <ul style="list-style-type: none"> • Director, Delivery, MRPV • Program Director, MRPV • Project Director, MRPV 	
Section 110	<p>On completion of an approved project, the project authority must notify the Project Minister of the project's completion.</p>	<ul style="list-style-type: none"> • Director General, MTIA • Chief Executive Officer, MRPV 	
Section 112	<p>The project authority may acquire an interest in land in the project area by agreement or by a compulsory process for the purposes of an approved project or any purpose connected with the approved project.</p>	<ul style="list-style-type: none"> • Director, Transport Property, DOT • Director General, MTIA • Chief Executive Officer, MRPV <p>and the following class of positions:</p> <ul style="list-style-type: none"> • Director, Delivery, MRPV 	<p>To be exercised by the Director, Transport Property, DOT, unless this is not practicable.</p> <p>Before acquiring an interest in any land, the delegate must give the Secretary particulars of the land and obtain the Secretary's approval in writing for the acquisition of that land.</p>

MTPF Act			
Column 1 MTPF Act Provision	Column 2 Summary of Provision	Column 3 Delegates	Column 4 Conditions or Limitations
Section 120(4), 120(5)	<p>The project authority must:</p> <ul style="list-style-type: none"> • section 120(4): make an offer for the payment of rent to the owner of the land for the authority's occupation of that land; and • section 120(5): if an amount of rent to be paid is not agreed upon, notify the Valuer-General in writing of any disagreement with an owner of land as to the amount of rent to be paid. 	<ul style="list-style-type: none"> • Director General, MTIA • Chief Executive Officer, MRPV • Director, Transport Property, DOT <p>and the following class of positions:</p> <ul style="list-style-type: none"> • Director, Delivery, MRPV 	
Section 121	<p>The project authority must:</p> <ul style="list-style-type: none"> • give the owner of land a condition report; • negotiate the contents of the condition report should the owner disagree; and • failing which, notify the Valuer General of a dispute under this section. 	<ul style="list-style-type: none"> • Director General, MTIA • Chief Executive Officer, MRPV • Director, Transport Property, DOT <p>and the following class of positions:</p> <ul style="list-style-type: none"> • Director, Delivery, MRPV • Program Director, MRPV • Project Director, MRPV 	
Section 123	<p>A project authority may transfer a building or structure in full or in part settlement of any compensation that the project authority is liable to pay.</p>	<ul style="list-style-type: none"> • Director General, MTIA • Chief Executive Officer, MRPV • Director, Transport Property, DOT 	
Section 124	<p>If a project authority acquires compulsorily under Division 1 of Part 6 to the MTPF Act part of a parcel of land owned by a person, the project authority may require that person to take as compensation land that adjoins the part of the parcel that was not acquired; and that is owned by the project authority or is surplus land.</p>	<ul style="list-style-type: none"> • Director General, MTIA • Chief Executive Officer, MRPV • Director, Transport Property, DOT 	

MTPF Act			
Column 1 MTPF Act Provision	Column 2 Summary of Provision	Column 3 Delegates	Column 4 Conditions or Limitations
Sections 127, 129	<p>The project authority is authorised to:</p> <ul style="list-style-type: none"> • section 127: compulsorily acquire a native title right or interest in land in the project area for the purposes of an approved project or any purpose connected with an approved project; • section 129: comply with relevant procedures under the Native Title Act 1993 (Vic.) for acquisition of native title rights and interests. 	<ul style="list-style-type: none"> • Director General, MTIA • Chief Executive Officer, MRPV • Director, Transport Property, DOT 	<p>To be exercised by the Director, Transport Property, DOT, unless this is not practicable.</p> <p>Before acquiring a native title right or interest in land in the project area, the delegate must give the Secretary particulars of the land and obtain the Secretary's approval in writing for the acquisition of that right or interest.</p>
Section 133	<p>The project authority may purchase land outside the project area for the purposes of an approved project, or preservation, restoration or provision of native habitat.</p>	<ul style="list-style-type: none"> • Director General, MTIA • Chief Executive Officer, MRPV • Director, Transport Property, DOT <p>and the following class of positions:</p> <ul style="list-style-type: none"> • Director, Delivery, MRPV 	<p>To be exercised by the Director, Transport Property, DOT, unless this is not practicable.</p> <p>Before purchasing any land outside the project area, the delegate must give the Secretary particulars of the land and obtain the Secretary's approval in writing for the purchase of that land.</p>
Section 137B	<p>The project authority may request the consent of the Project Minister to the surrender to the Crown of land held in fee simple if the land is intended to form part of a lease of land under section 177 of the MTPF Act.</p>	<ul style="list-style-type: none"> • Director General, MTIA • Chief Executive Officer, MRPV • Director, Transport Property, DOT 	
Section 143	<p>The project authority must notify the Minister administering the Crown Land (Reserves) Act 1978 (Vic.) of reservation of land under Subdivision 1, 2 or 2A or Division 6 of the MTPF Act.</p>	<ul style="list-style-type: none"> • Director General, MTIA • Chief Executive Officer, MRPV • Director, Transport Property, DOT 	

MTPF Act			
Column 1 MTPF Act Provision	Column 2 Summary of Provision	Column 3 Delegates	Column 4 Conditions or Limitations
Section 147	The project authority may transfer a building or structure from project land or project authority-owned land or Council-owned land, to other land owned by the Council as compensation.	<ul style="list-style-type: none"> • Director General, MTIA • Chief Executive Officer, MRPV • Director, Transport Property, DOT 	
Section 148	The project authority may require that adjoining land is provided as compensation to Council for land acquired compulsorily.	<ul style="list-style-type: none"> • Director General, MTIA • Chief Executive Officer, MRPV • Director, Transport Property, DOT 	
Section 151	The project authority may enter into possession of project land.	<ul style="list-style-type: none"> • Director General, MTIA • Chief Executive Officer, MRPV • Director, Transport Property, DOT <p>and the following class of positions:</p> <ul style="list-style-type: none"> • Director, Delivery, MRPV 	
Section 152	The project authority must diligently endeavour to obtain agreement with the occupier of project land on terms for entry into possession of the land.	<ul style="list-style-type: none"> • Director General, MTIA • Chief Executive Officer, MRPV • Director, Transport Property, DOT <p>and the following class of positions:</p> <ul style="list-style-type: none"> • Director, Delivery, MRPV • Program Director, MRPV • Project Director, MRPV 	
Section 155(1)	The project authority may enter an agreement in relation to the time of entry into possession of project land, with the consent of the Project Minister.	<ul style="list-style-type: none"> • Coordinator General, MTIA • Chief Executive Officer, MRPV • Director, Transport Property, DOT <p>and the following class of positions:</p> <ul style="list-style-type: none"> • Director, Delivery, MRPV • Program Director, MRPV • Project Director, MRPV 	

MTPF Act			
Column 1 MTPF Act Provision	Column 2 Summary of Provision	Column 3 Delegates	Column 4 Conditions or Limitations
Section 155(3)	The project authority must serve a copy of the certificate provided under section 155(1)(a) of the MTPF Act on the occupier.	<ul style="list-style-type: none"> • Director General, MTIA • Chief Executive Officer, MRPV • Director, Transport Property, DOT <p>and the following class of positions:</p> <ul style="list-style-type: none"> • Director, Delivery, MRPV • Program Director, MRPV • Project Director, MRPV 	
Section 156	The occupation period for project land may be extended by agreement between the project authority and the occupier of the project land.	<ul style="list-style-type: none"> • Director General, MTIA • Chief Executive Officer, MRPV • Director, Transport Property, DOT <p>and the following class of positions:</p> <ul style="list-style-type: none"> • Director, Delivery, MRPV • Program Director, MRPV • Project Director, MRPV 	
Section 158	Rent payable under the applicable Subdivision of the MTPF Act may be recovered as a debt due to the project authority in any court of competent jurisdiction.	<ul style="list-style-type: none"> • Director General, MTIA • Chief Executive Officer, MRPV • Director, Transport Property, DOT • Director, Commercial & Legal, MRPV 	
Section 159	The project authority may issue a warrant to the sheriff where entitled under the applicable Division to enter into possession of project land and an occupier of project land refuses to give up possession of the land or hinders entry to that land.	<ul style="list-style-type: none"> • Director General, MTIA • Chief Executive Officer, MRPV • Director, Commercial & Legal, MRPV 	

MTPF Act			
Column 1 MTPF Act Provision	Column 2 Summary of Provision	Column 3 Delegates	Column 4 Conditions or Limitations
Section 167	<p>The project authority:</p> <ul style="list-style-type: none"> section 167(1): may carry out or authorise works on public land inside or outside the project area for the purposes of the approved project; and section 167(2): must notify any Minister, public authority or Council that owns or manages the public land prior to works being carried out or performed. 	<ul style="list-style-type: none"> Director General, MTIA Chief Executive Officer, MRPV Director, Commercial & Legal, MRPV <p>and the following class of positions:</p> <ul style="list-style-type: none"> Director, Delivery, MRPV Program Director, MRPV Project Director, MRPV 	
Section 168A	<p>The project authority may carry out or authorise associated works where an applicable approval has been granted for those works or is not required.</p>	<ul style="list-style-type: none"> Director General, MTIA Chief Executive Officer, MRPV Director, Commercial & Legal, MRPV <p>and the following class of positions:</p> <ul style="list-style-type: none"> Director, Delivery, MRPV Program Director, MRPV Project Director, MRPV 	
Section 170	<p>The project authority may use or authorise use of any Crown land for the purposes of an approved project.</p>	<ul style="list-style-type: none"> Director General, MTIA Chief Executive Officer, MRPV Director, Commercial & Legal, MRPV <p>and the following class of positions:</p> <ul style="list-style-type: none"> Director, Delivery, MRPV Program Director, MRPV Project Director, MRPV 	

MTPF Act			
Column 1 MTPF Act Provision	Column 2 Summary of Provision	Column 3 Delegates	Column 4 Conditions or Limitations
Section 171	The project authority may carry out or authorise works on any land within an easement acquired under the applicable Part of the MTPF Act.	<ul style="list-style-type: none"> • Director General, MTIA • Chief Executive Officer, MRPV • Director, Commercial & Legal, MRPV <p>and the following class of positions:</p> <ul style="list-style-type: none"> • Director, Delivery, MRPV • Program Director, MRPV • Project Director, MRPV 	
Section 171A	The project authority may transfer to a utility any easement acquired over project land for the purposes of relocating utility infrastructure as a result of an approved project.	<ul style="list-style-type: none"> • Director General, MTIA • Chief Executive Officer, MRPV • Director, Transport Property, DOT • Director, Commercial & Legal, MRPV <p>and the following class of positions:</p> <ul style="list-style-type: none"> • Director, Delivery, MRPV • Program Director, MRPV • Project Director, MRPV 	
Section 173	The project authority may issue a licence to any person to enter and use all or any part of project land that is Crown land, or land that the project authority holds in fee simple, for the purposes of the approved project.	<ul style="list-style-type: none"> • Director General, MTIA • Chief Executive Officer, MRPV • Director, Transport Property, DOT <p>and the following class of positions:</p> <ul style="list-style-type: none"> • Director, Delivery, MRPV • Program Director, MRPV • Project Director, MRPV 	
Section 184	The project authority may enter into an agreement concerning the use or development of surplus land upon or in anticipation of disposing of the whole of its interest in the land.	<ul style="list-style-type: none"> • Director General, MTIA • Chief Executive Officer, MRPV • Director, Transport Property, DOT 	

MTPF Act			
Column 1 MTPF Act Provision	Column 2 Summary of Provision	Column 3 Delegates	Column 4 Conditions or Limitations
Section 185	The project authority may sell, lease or licence any surplus land held in fee simple.	<ul style="list-style-type: none"> • Director General, MTIA • Chief Executive Officer, MRPV • Director, Transport Property, DOT 	
Section 186	<p>The project authority may:</p> <ul style="list-style-type: none"> • open, discontinue, construct, relocate or realign roads, and close any road to traffic; • carry out improvements to roads in the project area; • construct roads over or under roads constructed or to be constructed in the project area; • construct any road in the project area over or under any other roads; and • cause fences, posts, or other structures to be erected along any road constructed or to be constructed in the project area, or across any entrance, approach or means of access to, any road constructed or to be constructed in the project area. 	<ul style="list-style-type: none"> • Director General, MTIA • Chief Executive Officer, MRPV • Director, Commercial & Legal, MRPV <p>and the following class of positions:</p> <ul style="list-style-type: none"> • Director, Delivery, MRPV • Program Director, MRPV • Project Director, MRPV 	
Section 187	The project authority must advise the coordinating road authority before exercising any power under section 186.	<ul style="list-style-type: none"> • Director General, MTIA • Chief Executive Officer, MRPV • Director, Commercial & Legal, MRPV <p>and the following class of positions:</p> <ul style="list-style-type: none"> • Director, Delivery, MRPV • Program Director, MRPV • Project Director, MRPV 	

MTPF Act			
Column 1 MTPF Act Provision	Column 2 Summary of Provision	Column 3 Delegates	Column 4 Conditions or Limitations
Section 189	The project authority must cause notice of a decision under section 186 to be published in the Government Gazette and in a newspaper being circulated throughout the area affected by the decision.	<ul style="list-style-type: none"> • Director General, MTIA • Chief Executive Officer, MRPV • Director, Commercial & Legal, MRPV <p>and the following class of positions:</p> <ul style="list-style-type: none"> • Director, Delivery, MRPV • Program Director, MRPV • Project Director, MRPV 	
Section 190	The project authority may temporarily close a road to traffic for the purposes of an approved project if considered necessary to do so for works on the road or neighbouring land to be carried out.	<ul style="list-style-type: none"> • Director General, MTIA • Chief Executive Officer, MRPV • Director, Commercial & Legal, MRPV <p>and the following class of positions:</p> <ul style="list-style-type: none"> • Director, Delivery, MRPV • Program Director, MRPV • Project Director, MRPV 	
Section 196	The project authority may establish or cause to be established as a 'restricted access area' a the project area or land temporarily occupied under section 75 of the Land Acquisition Compensation Act 1986 by use of fencing, barriers, other temporary or permanent means of physical demarcation or signage on or in proximity to the area.	<ul style="list-style-type: none"> • Director General, MTIA • Chief Executive Officer, MRPV • Director, Commercial & Legal, MRPV <p>and the following class of positions:</p> <ul style="list-style-type: none"> • Director, Delivery, MRPV • Program Director, MRPV • Project Director, MRPV 	

MTPF Act			
Column 1 MTPF Act Provision	Column 2 Summary of Provision	Column 3 Delegates	Column 4 Conditions or Limitations
Section 198	The project authority must issue identity cards to authorised officers appointed for the purposes of exercising functions in respect of restricted access areas.	<ul style="list-style-type: none"> • Director General, MTIA • Chief Executive Officer, MRPV • Director, Commercial & Legal, MRPV <p>and the following class of positions:</p> <ul style="list-style-type: none"> • Director, Delivery, MRPV • Program Director, MRPV • Project Director, MRPV 	
Section 199	The project authority may, by issuing a certificate or making a declaration, authorise a person or class of person to enter and remain in a restricted access area for the purposes of preparing or conducting activities for the purposes of an approved project or carrying out ancillary activities.	<ul style="list-style-type: none"> • Director General, MTIA • Chief Executive Officer, MRPV • Director, Commercial & Legal, MRPV <p>and the following class of positions:</p> <ul style="list-style-type: none"> • Director, Delivery, MRPV • Program Director, MRPV • Project Director, MRPV 	
Sections 200, 201	The project authority may warn any person (other than owner of land or a person authorised in writing by the owner or under the MTPF Act) to leave any part of the restricted access area under the applicable Division of the MTPF Act.	<ul style="list-style-type: none"> • Director General, MTIA • Chief Executive Officer, MRPV • Director, Commercial & Legal, MRPV <p>and the following class of positions:</p> <ul style="list-style-type: none"> • Director, Delivery, MRPV • Program Director, MRPV • Project Director, MRPV 	

MTPF Act			
Column 1 MTPF Act Provision	Column 2 Summary of Provision	Column 3 Delegates	Column 4 Conditions or Limitations
Sections 211, 211A	<p>The project authority:</p> <ul style="list-style-type: none"> section 211: must take all reasonable steps to identify all utility infrastructure, and every utility that owns such infrastructure, that may be affected by the development of the declared project; and section 211A: may give a notice to a utility identified under section 211 of the MTPF Act requiring it state whether it owns, operates or controls the relevant utility infrastructure in the specified area, describe the nature of that infrastructure and its location, and provide plans showing the location of that infrastructure. 	<ul style="list-style-type: none"> Director General, MTIA Chief Executive Officer, MRPV Director, Commercial & Legal, MRPV <p>and the following class of positions:</p> <ul style="list-style-type: none"> Director, Delivery, MRPV Program Director, MRPV Project Director, MRPV 	
Section 213	<p>Following the applicable notice period, the project authority may give written notice to a utility of an intention to commence negotiations with the utility for the purpose of entering a utility agreement.</p>	<ul style="list-style-type: none"> Director General, MTIA Chief Executive Officer, MRPV Director, Commercial & Legal, MRPV <p>and the following class of positions:</p> <ul style="list-style-type: none"> Director, Delivery, MRPV Program Director, MRPV Project Director, MRPV 	
Section 214	<p>The project authority (and the relevant utility) must use all reasonable endeavours to negotiate a utility agreement within 50 business days after notice is given under section 213 of the MTPF Act.</p>	<ul style="list-style-type: none"> Director General, MTIA Chief Executive Officer, MRPV Director, Commercial & Legal, MRPV <p>and the following class of positions:</p> <ul style="list-style-type: none"> Director, Delivery, MRPV Program Director, MRPV Project Director, MRPV 	

MTPF Act			
Column 1 MTPF Act Provision	Column 2 Summary of Provision	Column 3 Delegates	Column 4 Conditions or Limitations
Section 215	The project authority must give written notice to the Project Minister and Utility Minister for the utility if a utility agreement is not entered into between the parties within the applicable 50 business day period.	<ul style="list-style-type: none"> • Director General, MTIA • Chief Executive Officer, MRPV • Director, Commercial & Legal, MRPV <p>and the following class of positions:</p> <ul style="list-style-type: none"> • Director, Delivery, MRPV • Program Director, MRPV • Project Director, MRPV 	
Sections 216, 217, 218, 224, 225, 227	<p>The project authority may exercise the following project functions for dispute resolution and termination in relation to a utility agreement:</p> <ul style="list-style-type: none"> • section 216: give notice to the other party that a dispute exists; • section 217: use reasonable endeavours to agree on an expert for resolving the dispute; • section 218: inform the Project Minister if the parties have agreed on an expert to be appointed, or otherwise if there has been no such agreement; • section 224: provide a draft utility agreement that identifies the applicable matters in relation to which the parties do not agree; • section 225: make a submission to the expert in relation to the dispute; and • section 227: agree to termination or revocation of a utility agreement approved in accordance with section 226(4) of the MTPF Act. 	<ul style="list-style-type: none"> • Director General, MTIA • Chief Executive Officer, MRPV • Director, Commercial & Legal, MRPV <p>and the following class of positions:</p> <ul style="list-style-type: none"> • Director, Delivery, MRPV • Program Director, MRPV • Project Director, MRPV 	

MTPF Act			
Column 1 MTPF Act Provision	Column 2 Summary of Provision	Column 3 Delegates	Column 4 Conditions or Limitations
Sections 232, 233, 234	<p>The project authority may exercise the following project functions in relation to unnotified utility infrastructure:</p> <ul style="list-style-type: none"> • section 232: give written notice to utilities of the project authority's intention to remove, relocate or protect the infrastructure (as the case may be), and require the utility to agree to the relevant works or carry out the works itself; • section 233: if the project authority does not receive a response or the utility does not agree to the relevant works specified in a notice provided under section 232 of the MTPF Act, remove, relocate or carry out works in relation to utility infrastructure, and give the utility an estimate of costs for which the utility is liable for; and • section 234: notify the relevant utility of any damage caused to unnotified utility infrastructure, and undertake the applicable protection, relocation or removal activities in respect of utility infrastructure (including, if an emergency situation occurs, taking all reasonable steps to end the emergency). 	<ul style="list-style-type: none"> • Director General, MTIA • Chief Executive Officer, MRPV • Director, Commercial & Legal, MRPV <p>and the following class of positions:</p> <ul style="list-style-type: none"> • Director, Delivery, MRPV • Program Director, MRPV • Project Director, MRPV 	

LACA			
Column 1 LACA Provision	Column 2 Summary of Provision	Column 3 Delegates	Column 4 Conditions or Limitations
Section 74 (as modified by section 118(5) of the MTPF Act)	<p>The project authority may, or may authorise another person to:</p> <ul style="list-style-type: none"> enter and remain upon any land (with assistants, vehicles, machinery or equipment); affix or establish any trigonometric stations, survey pegs, marks or poles; undertake flora and fauna surveys, and archaeological investigations; and dig or bore land, and take samples of soil, rock, ground water or minerals. 	<ul style="list-style-type: none"> Director General, MTIA Chief Executive Officer, MRPV Director, Commercial & Legal, MRPV Director, Transport Property, DOT <p>and the following class of positions:</p> <ul style="list-style-type: none"> Director, Delivery, MRPV 	<p>To be exercised by the Director, Transport Property, DOT, unless this is not practicable.</p>
Section 75 (as modified by section 119 of the MTPF Act)	<p>The project authority may, or may authorise another person to enter upon and occupy any land for the purposes:</p> <ul style="list-style-type: none"> digging and taking from the land any clay, stone, gravel, earth or other substance; depositing any material on the land; making cuttings or excavations; taking timber from the land; making and using roads on the land; manufacturing on the land any materials required; demolishing structures (other than places of residence or business); carrying out works on drainage channels, streams or other waterways, or works relating to the diversion of drainage channels, streams or other waterways; or erecting temporary workshops, sheds and buildings. 	<ul style="list-style-type: none"> Director General, MTIA Chief Executive Officer, MRPV Director, Commercial & Legal, MRPV Director, Transport Property, DOT <p>and the following class of positions:</p> <ul style="list-style-type: none"> Director, Delivery, MRPV 	<p>To be exercised by the Director, Transport Property, DOT, unless this is not practicable.</p>

**Major Transport Projects Facilitation Act 2009, Transport Integration Act 2010 and
Land Acquisition and Compensation Act 1986**

INSTRUMENT OF DELEGATION BY SECRETARY

FITZSIMONS LANE UPGRADE

I, Paul Younis, Secretary to the Department of Transport (**Secretary**) as project authority of the Fitzsimons Lane Upgrade project (**Project**), a declared project for which designation of the project area in accordance with Part 4 of the **Major Transport Projects Facilitation Act 2009** (Vic.) (**MTPF Act**) occurred on 27 March 2020, and as project authority being also:

- taken to be specified as a determining referral authority in the Banyule Planning Scheme, Manningham Planning Scheme and Nillumbik Planning Scheme under the **Planning and Environment Act 1987** (Vic.) (**Planning and Environment Act 1987**) by operation of section 102A of the MTPF Act (**determining referral authority**); and
- the Authority for the purpose of the **Land Acquisition and Compensation Act 1986** (Vic.) (**LACA**) as applied by section 113 of the MTPF Act (**Authority**) –

in exercise of the powers vested in me under section 104 of the MTPF Act, section 39 of the **Transport Integration Act 2010** and any and all other enabling powers, hereby delegate to the person(s) from time to time employed within the Department of Transport (**DOT**) (which includes the Major Transport Infrastructure Authority, the administrative office existing in relation to DOT that is responsible for delivery of the Project (**MTIA**) and occupying the positions specified in Column 3 of the Schedule to this instrument (each a **Delegate**) such of:

- the project functions and powers conferred on me under the MTPF Act in respect of the Project;
- my powers, duties and functions as determining referral authority in relation to land in the project area; and
- my powers and functions as the Authority –

as are specified for the Delegate in Column 1 and summarised in Column 2 of the Schedule to this instrument, subject to the following conditions and limitations:

11. any condition or limitation that is specified in Column 4 of the Schedule to this instrument with respect to a power, duty or function that is specified in Column 1 of the Schedule to this instrument; and
12. the condition that the power, duty or function may only be exercised for the purpose of the Project.

If the Delegate considers that a project function is one that, in the particular circumstances, requires referral to the Secretary, then before exercising the project function the Delegate should inform and consult with the Secretary.

In the interpretation of this instrument, the summary of a provision set out in Column 2 of the Schedule to this instrument is for convenience only and, unless a contrary intention appears, does not amend, substitute or delete any part of a provision of the MTPF Act or LACA set out in Column 1 of the Schedule to this instrument or otherwise affect the scope or effect of the power, duty or function delegated.

A Delegate is not authorised to delegate or sub-delegate any power delegated under this instrument.

This delegation will remain valid until it is revoked.

The delegation I signed on 23 April 2020 delegating to persons employed within DOT certain powers, duties and functions in respect of the Project, is hereby revoked.

Dated 2 September 2020

PAUL YOUNIS
Secretary to the Department of Transport

SCHEDULE

MTPF Act			
Column 1 MTPF Act Provision	Column 2 Summary of Provision	Column 3 Delegates	Column 4 Conditions or Limitations
Section 96	The project authority may request the Planning Minister to vary the project area for the approved project.	<ul style="list-style-type: none"> • Director General, MTIA • Chief Executive Officer, Major Road Projects Victoria (MRPV) • Director, Commercial & Legal, MRPV 	
Section 101	<p>The project authority may exercise the project authority's functions, summarised as follows:</p> <ul style="list-style-type: none"> • section 101(a): facilitating development of the approved project; • sections 101(b), (c): evaluating submissions from and negotiating with interested parties; • sections 101(d), (e), (f): making recommendations in relation to, and entering and administering contractual arrangements for, development or delivery of the approved project; • sections 101(g), (h), (i): facilitating and coordinating consultations, and negotiating and entering into arrangements, and coordinating, with statutory authorities, agencies of the State and other bodies or persons involved in, or affected by, development or operation of the approved project; • section 101(i): making recommendations to the Project Minister in relation to facilitating the approved project; • section 101(j): ensuring that agreements and arrangements between the State and any other person for, or relating to, the development or delivery of the approved project are performed in accordance with their terms; • section 101(k): commissioning transport infrastructure that is developed as part of the approved project; • section 101(l): undertaking any other functions conferred on the project authority under the MTPF Act or any other Act. 	<ul style="list-style-type: none"> • Director General, MTIA • Chief Executive Officer, MRPV • Director, Commercial & Legal, MRPV <p>and the following class of positions:</p> <ul style="list-style-type: none"> • Director, Delivery, MRPV 	

MTPF Act			
Column 1 MTPF Act Provision	Column 2 Summary of Provision	Column 3 Delegates	Column 4 Conditions or Limitations
Section 102	<p>For the purpose of performing its functions, and in addition to all other powers conferred on it by or under any other Act or law, exercising:</p> <ul style="list-style-type: none"> • section 102(1): a specified project power or power conferred on it by or under the MTPF Act; and • Section 102(2): do all other things necessary or convenient to be done for, or in connection with, or as incidental to, the performance of project functions under the MTPF Act. 	<ul style="list-style-type: none"> • Director General, MTIA • Chief Executive Officer, MRPV • Director, Commercial & Legal, MRPV • Director, Transport Property, DOT <p>and the following class of positions:</p> <ul style="list-style-type: none"> • Director, Delivery, MRPV 	
Section 102A	<p>The project authority for an approved project is taken to be specified as a determining referral authority in any planning scheme under the Planning and Environment Act.</p>	<ul style="list-style-type: none"> • Director General, MTIA • Chief Executive Officer, MRPV • Director, Commercial and Legal, MRPV <p>and the following class of positions:</p> <ul style="list-style-type: none"> • Director, Delivery, MRPV • Program Director, MRPV • Project Director, MRPV 	
Section 110	<p>On completion of an approved project, the project authority must notify the Project Minister of the project's completion.</p>	<ul style="list-style-type: none"> • Director General, MTIA • Chief Executive Officer, MRPV 	
Section 112	<p>The project authority may acquire an interest in land in the project area by agreement or by a compulsory process for the purposes of an approved project or any purpose connected with the approved project.</p>	<ul style="list-style-type: none"> • Director, Transport Property, DOT • Director General, MTIA • Chief Executive Officer, MRPV <p>and the following class of positions:</p> <ul style="list-style-type: none"> • Director, Delivery, MRPV 	<p>To be exercised by the Director, Transport Property, DOT, unless this is not practicable.</p> <p>Before acquiring an interest in any land, the delegate must give the Secretary particulars of the land and obtain the Secretary's approval in writing for the acquisition of that land.</p>

MTPF Act			
Column 1 MTPF Act Provision	Column 2 Summary of Provision	Column 3 Delegates	Column 4 Conditions or Limitations
Section 120(4), 120(5)	<p>The project authority must:</p> <ul style="list-style-type: none"> • section 120(4): make an offer for the payment of rent to the owner of the land for the authority's occupation of that land; and • section 120(5): if an amount of rent to be paid is not agreed upon, notify the Valuer-General in writing of any disagreement with an owner of land as to the amount of rent to be paid. 	<ul style="list-style-type: none"> • Director General, MTIA • Chief Executive Officer, MRPV • Director, Transport Property, DOT <p>and the following class of positions:</p> <ul style="list-style-type: none"> • Director, Delivery, MRPV 	
Section 121	<p>The project authority must:</p> <ul style="list-style-type: none"> • give the owner of land a condition report; • negotiate the contents of the condition report should the owner disagree; and • failing which, notify the Valuer General of a dispute under this section. 	<ul style="list-style-type: none"> • Director General, MTIA • Chief Executive Officer, MRPV • Director, Transport Property, DOT <p>and the following class of positions:</p> <ul style="list-style-type: none"> • Director, Delivery, MRPV • Program Director, MRPV • Project Director, MRPV 	
Section 123	<p>A project authority may transfer a building or structure in full or in part settlement of any compensation that the project authority is liable to pay.</p>	<ul style="list-style-type: none"> • Director General, MTIA • Chief Executive Officer, MRPV • Director, Transport Property, DOT 	
Section 124	<p>If a project authority acquires compulsorily under Division 1 of Part 6 to the MTPF Act part of a parcel of land owned by a person, the project authority may require that person to take as compensation land that adjoins the part of the parcel that was not acquired; and that is owned by the project authority or is surplus land.</p>	<ul style="list-style-type: none"> • Director General, MTIA • Chief Executive Officer, MRPV • Director, Transport Property, DOT 	

MTPF Act			
Column 1 MTPF Act Provision	Column 2 Summary of Provision	Column 3 Delegates	Column 4 Conditions or Limitations
Sections 127, 129	<p>The project authority is authorised to:</p> <ul style="list-style-type: none"> section 127: compulsorily acquire a native title right or interest in land in the project area for the purposes of an approved project or any purpose connected with an approved project; section 129: comply with relevant procedures under the Native Title Act 1993 (Vic.) for acquisition of native title rights and interests. 	<ul style="list-style-type: none"> Director General, MTIA Chief Executive Officer, MRPV Director, Transport Property, DOT 	<p>To be exercised by the Director, Transport Property, DOT, unless this is not practicable.</p> <p>Before acquiring a native title right or interest in land in the project area, the delegate must give the Secretary particulars of the land and obtain the Secretary's approval in writing for the acquisition of that right or interest.</p>
Section 133	<p>The project authority may purchase land outside the project area for the purposes of an approved project, or preservation, restoration or provision of native habitat.</p>	<ul style="list-style-type: none"> Director General, MTIA Chief Executive Officer, MRPV Director, Transport Property, DOT <p>and the following class of positions:</p> <ul style="list-style-type: none"> Director, Delivery, MRPV 	<p>To be exercised by the Director, Transport Property, DOT, unless this is not practicable.</p> <p>Before purchasing any land outside the project area, the delegate must give the Secretary particulars of the land and obtain the Secretary's approval in writing for the purchase of that land.</p>
Section 137B	<p>The project authority may request the consent of the Project Minister to the surrender to the Crown of land held in fee simple if the land is intended to form part of a lease of land under section 177 of the MTPF Act.</p>	<ul style="list-style-type: none"> Director General, MTIA Chief Executive Officer, MRPV Director, Transport Property, DOT 	
Section 143	<p>The project authority must notify the Minister administering the Crown Land (Reserves) Act 1978 (Vic.) of reservation of land under Subdivision 1, 2 or 2A or Division 6 of the MTPF Act.</p>	<ul style="list-style-type: none"> Director General, MTIA Chief Executive Officer, MRPV Director, Transport Property, DOT 	

MTPF Act			
Column 1 MTPF Act Provision	Column 2 Summary of Provision	Column 3 Delegates	Column 4 Conditions or Limitations
Section 147	The project authority may transfer a building or structure from project land or project authority-owned land or Council-owned land, to other land owned by the Council as compensation.	<ul style="list-style-type: none"> • Director General, MTIA • Chief Executive Officer, MRPV • Director, Transport Property, DOT 	
Section 148	The project authority may require that adjoining land is provided as compensation to Council for land acquired compulsorily.	<ul style="list-style-type: none"> • Director General, MTIA • Chief Executive Officer, MRPV • Director, Transport Property, DOT 	
Section 151	The project authority may enter into possession of project land.	<ul style="list-style-type: none"> • Director General, MTIA • Chief Executive Officer, MRPV • Director, Transport Property, DOT <p>and the following class of positions:</p> <ul style="list-style-type: none"> • Director, Delivery, MRPV 	
Section 152	The project authority must diligently endeavour to obtain agreement with the occupier of project land on terms for entry into possession of the land.	<ul style="list-style-type: none"> • Director General, MTIA • Chief Executive Officer, MRPV • Director, Transport Property, DOT <p>and the following class of positions:</p> <ul style="list-style-type: none"> • Director, Delivery, MRPV • Program Director, MRPV • Project Director, MRPV 	
Section 155(1)	The project authority may enter an agreement in relation to the time of entry into possession of project land, with the consent of the Project Minister.	<ul style="list-style-type: none"> • Coordinator General, MTIA • Chief Executive Officer, MRPV • Director, Transport Property, DOT <p>and the following class of positions:</p> <ul style="list-style-type: none"> • Director, Delivery, MRPV • Program Director, MRPV • Project Director, MRPV 	

MTPF Act			
Column 1 MTPF Act Provision	Column 2 Summary of Provision	Column 3 Delegates	Column 4 Conditions or Limitations
Section 155(3)	The project authority must serve a copy of the certificate provided under section 155(1)(a) of the MTPF Act on the occupier.	<ul style="list-style-type: none"> • Director General, MTIA • Chief Executive Officer, MRPV • Director, Transport Property, DOT <p>and the following class of positions:</p> <ul style="list-style-type: none"> • Director, Delivery, MRPV • Program Director, MRPV • Project Director, MRPV 	
Section 156	The occupation period for project land may be extended by agreement between the project authority and the occupier of the project land.	<ul style="list-style-type: none"> • Director General, MTIA • Chief Executive Officer, MRPV • Director, Transport Property, DOT <p>and the following class of positions:</p> <ul style="list-style-type: none"> • Director, Delivery, MRPV • Program Director, MRPV • Project Director, MRPV 	
Section 158	Rent payable under the applicable Subdivision of the MTPF Act may be recovered as a debt due to the project authority in any court of competent jurisdiction.	<ul style="list-style-type: none"> • Director General, MTIA • Chief Executive Officer, MRPV • Director, Transport Property, DOT • Director, Commercial & Legal, MRPV 	
Section 159	The project authority may issue a warrant to the sheriff where entitled under the applicable Division to enter into possession of project land and an occupier of project land refuses to give up possession of the land or hinders entry to that land.	<ul style="list-style-type: none"> • Director General, MTIA • Chief Executive Officer, MRPV • Director, Commercial & Legal, MRPV 	

MTPF Act			
Column 1 MTPF Act Provision	Column 2 Summary of Provision	Column 3 Delegates	Column 4 Conditions or Limitations
Section 167	<p>The project authority:</p> <ul style="list-style-type: none"> • section 167(1): may carry out or authorise works on public land inside or outside the project area for the purposes of the approved project; and • section 167(2): must notify any Minister, public authority or Council that owns or manages the public land prior to works being carried out or performed. 	<ul style="list-style-type: none"> • Director General, MTIA • Chief Executive Officer, MRPV • Director, Commercial & Legal, MRPV <p>and the following class of positions:</p> <ul style="list-style-type: none"> • Director, Delivery, MRPV • Program Director, MRPV • Project Director, MRPV 	
Section 168A	<p>The project authority may carry out or authorise associated works where an applicable approval has been granted for those works or is not required.</p>	<ul style="list-style-type: none"> • Director General, MTIA • Chief Executive Officer, MRPV • Director, Commercial & Legal, MRPV <p>and the following class of positions:</p> <ul style="list-style-type: none"> • Director, Delivery, MRPV • Program Director, MRPV • Project Director, MRPV 	
Section 170	<p>The project authority may use or authorise use of any Crown land for the purposes of an approved project.</p>	<ul style="list-style-type: none"> • Director General, MTIA • Chief Executive Officer, MRPV • Director, Commercial & Legal, MRPV <p>and the following class of positions:</p> <ul style="list-style-type: none"> • Director, Delivery, MRPV • Program Director, MRPV • Project Director, MRPV 	

MTPF Act			
Column 1 MTPF Act Provision	Column 2 Summary of Provision	Column 3 Delegates	Column 4 Conditions or Limitations
Section 171	The project authority may carry out or authorise works on any land within an easement acquired under the applicable Part of the MTPF Act.	<ul style="list-style-type: none"> • Director General, MTIA • Chief Executive Officer, MRPV • Director, Commercial & Legal, MRPV <p>and the following class of positions:</p> <ul style="list-style-type: none"> • Director, Delivery, MRPV • Program Director, MRPV • Project Director, MRPV 	
Section 171A	The project authority may transfer to a utility any easement acquired over project land for the purposes of relocating utility infrastructure as a result of an approved project.	<ul style="list-style-type: none"> • Director General, MTIA • Chief Executive Officer, MRPV • Director, Transport Property, DOT • Director, Commercial & Legal, MRPV <p>and the following class of positions:</p> <ul style="list-style-type: none"> • Director, Delivery, MRPV • Program Director, MRPV • Project Director, MRPV 	
Section 173	The project authority may issue a licence to any person to enter and use all or any part of project land that is Crown land, or land that the project authority holds in fee simple, for the purposes of the approved project.	<ul style="list-style-type: none"> • Director General, MTIA • Chief Executive Officer, MRPV • Director, Transport Property, DOT <p>and the following class of positions:</p> <ul style="list-style-type: none"> • Director, Delivery, MRPV • Program Director, MRPV • Project Director, MRPV 	
Section 184	The project authority may enter into an agreement concerning the use or development of surplus land upon or in anticipation of disposing of the whole of its interest in the land.	<ul style="list-style-type: none"> • Director General, MTIA • Chief Executive Officer, MRPV • Director, Transport Property, DOT 	

MTPF Act			
Column 1 MTPF Act Provision	Column 2 Summary of Provision	Column 3 Delegates	Column 4 Conditions or Limitations
Section 185	The project authority may sell, lease or licence any surplus land held in fee simple.	<ul style="list-style-type: none"> • Director General, MTIA • Chief Executive Officer, MRPV • Director, Transport Property, DOT 	
Section 186	<p>The project authority may:</p> <ul style="list-style-type: none"> • open, discontinue, construct, relocate or realign roads, and close any road to traffic; • carry out improvements to roads in the project area; • construct roads over or under roads constructed or to be constructed in the project area; • construct any road in the project area over or under any other roads; and • cause fences, posts, or other structures to be erected along any road constructed or to be constructed in the project area, or across any entrance, approach or means of access to, any road constructed or to be constructed in the project area. 	<ul style="list-style-type: none"> • Director General, MTIA • Chief Executive Officer, MRPV • Director, Commercial & Legal, MRPV <p>and the following class of positions:</p> <ul style="list-style-type: none"> • Director, Delivery, MRPV • Program Director, MRPV • Project Director, MRPV 	
Section 187	The project authority must advise the coordinating road authority before exercising any power under section 186.	<ul style="list-style-type: none"> • Director General, MTIA • Chief Executive Officer, MRPV • Director, Commercial & Legal, MRPV <p>and the following class of positions:</p> <ul style="list-style-type: none"> • Director, Delivery, MRPV • Program Director, MRPV • Project Director, MRPV 	

MTPF Act			
Column 1 MTPF Act Provision	Column 2 Summary of Provision	Column 3 Delegates	Column 4 Conditions or Limitations
Section 189	The project authority must cause notice of a decision under section 186 to be published in the Government Gazette and in a newspaper being circulated throughout the area affected by the decision.	<ul style="list-style-type: none"> • Director General, MTIA • Chief Executive Officer, MRPV • Director, Commercial & Legal, MRPV <p>and the following class of positions:</p> <ul style="list-style-type: none"> • Director, Delivery, MRPV • Program Director, MRPV • Project Director, MRPV 	
Section 190	The project authority may temporarily close a road to traffic for the purposes of an approved project if considered necessary to do so for works on the road or neighbouring land to be carried out.	<ul style="list-style-type: none"> • Director General, MTIA • Chief Executive Officer, MRPV • Director, Commercial & Legal, MRPV <p>and the following class of positions:</p> <ul style="list-style-type: none"> • Director, Delivery, MRPV • Program Director, MRPV • Project Director, MRPV 	
Section 196	The project authority may establish or cause to be established as a 'restricted access area' a the project area or land temporarily occupied under section 75 of the Land Acquisition Compensation Act 1986 by use of fencing, barriers, other temporary or permanent means of physical demarcation or signage on or in proximity to the area.	<ul style="list-style-type: none"> • Director General, MTIA • Chief Executive Officer, MRPV • Director, Commercial & Legal, MRPV <p>and the following class of positions:</p> <ul style="list-style-type: none"> • Director, Delivery, MRPV • Program Director, MRPV • Project Director, MRPV 	

MTPF Act			
Column 1 MTPF Act Provision	Column 2 Summary of Provision	Column 3 Delegates	Column 4 Conditions or Limitations
Section 198	The project authority must issue identity cards to authorised officers appointed for the purposes of exercising functions in respect of restricted access areas.	<ul style="list-style-type: none"> • Director General, MTIA • Chief Executive Officer, MRPV • Director, Commercial & Legal, MRPV <p>and the following class of positions:</p> <ul style="list-style-type: none"> • Director, Delivery, MRPV • Program Director, MRPV • Project Director, MRPV 	
Section 199	The project authority may, by issuing a certificate or making a declaration, authorise a person or class of person to enter and remain in a restricted access area for the purposes of preparing or conducting activities for the purposes of an approved project or carrying out ancillary activities.	<ul style="list-style-type: none"> • Director General, MTIA • Chief Executive Officer, MRPV • Director, Commercial & Legal, MRPV <p>and the following class of positions:</p> <ul style="list-style-type: none"> • Director, Delivery, MRPV • Program Director, MRPV • Project Director, MRPV 	
Sections 200, 201	The project authority may warn any person (other than owner of land or a person authorised in writing by the owner or under the MTPF Act) to leave any part of the restricted access area under the applicable Division of the MTPF Act.	<ul style="list-style-type: none"> • Director General, MTIA • Chief Executive Officer, MRPV • Director, Commercial & Legal, MRPV <p>and the following class of positions:</p> <ul style="list-style-type: none"> • Director, Delivery, MRPV • Program Director, MRPV • Project Director, MRPV 	

MTPF Act			
Column 1 MTPF Act Provision	Column 2 Summary of Provision	Column 3 Delegates	Column 4 Conditions or Limitations
Sections 211, 211A	<p>The project authority:</p> <ul style="list-style-type: none"> section 211: must take all reasonable steps to identify all utility infrastructure, and every utility that owns such infrastructure, that may be affected by the development of the declared project; and section 211A: may give a notice to a utility identified under section 211 of the MTPF Act requiring it state whether it owns, operates or controls the relevant utility infrastructure in the specified area, describe the nature of that infrastructure and its location, and provide plans showing the location of that infrastructure. 	<ul style="list-style-type: none"> Director General, MTIA Chief Executive Officer, MRPV Director, Commercial & Legal, MRPV <p>and the following class of positions:</p> <ul style="list-style-type: none"> Director, Delivery, MRPV Program Director, MRPV Project Director, MRPV 	
Section 213	<p>Following the applicable notice period, the project authority may give written notice to a utility of an intention to commence negotiations with the utility for the purpose of entering a utility agreement.</p>	<ul style="list-style-type: none"> Director General, MTIA Chief Executive Officer, MRPV Director, Commercial & Legal, MRPV <p>and the following class of positions:</p> <ul style="list-style-type: none"> Director, Delivery, MRPV Program Director, MRPV Project Director, MRPV 	
Section 214	<p>The project authority (and the relevant utility) must use all reasonable endeavours to negotiate a utility agreement within 50 business days after notice is given under section 213 of the MTPF Act.</p>	<ul style="list-style-type: none"> Director General, MTIA Chief Executive Officer, MRPV Director, Commercial & Legal, MRPV <p>and the following class of positions:</p> <ul style="list-style-type: none"> Director, Delivery, MRPV Program Director, MRPV Project Director, MRPV 	

MTPF Act			
Column 1 MTPF Act Provision	Column 2 Summary of Provision	Column 3 Delegates	Column 4 Conditions or Limitations
Section 215	The project authority must give written notice to the Project Minister and Utility Minister for the utility if a utility agreement is not entered into between the parties within the applicable 50 business day period.	<ul style="list-style-type: none"> • Director General, MTIA • Chief Executive Officer, MRPV • Director, Commercial & Legal, MRPV <p>and the following class of positions:</p> <ul style="list-style-type: none"> • Director, Delivery, MRPV • Program Director, MRPV • Project Director, MRPV 	
Sections 216, 217, 218, 224, 225, 227	<p>The project authority may exercise the following project functions for dispute resolution and termination in relation to a utility agreement:</p> <ul style="list-style-type: none"> • section 216: give notice to the other party that a dispute exists; • section 217: use reasonable endeavours to agree on an expert for resolving the dispute; • section 218: inform the Project Minister if the parties have agreed on an expert to be appointed, or otherwise if there has been no such agreement; • section 224: provide a draft utility agreement that identifies the applicable matters in relation to which the parties do not agree; • section 225: make a submission to the expert in relation to the dispute; and • section 227: agree to termination or revocation of a utility agreement approved in accordance with section 226(4) of the MTPF Act. 	<ul style="list-style-type: none"> • Director General, MTIA • Chief Executive Officer, MRPV • Director, Commercial & Legal, MRPV <p>and the following class of positions:</p> <ul style="list-style-type: none"> • Director, Delivery, MRPV • Program Director, MRPV • Project Director, MRPV 	

MTPF Act			
Column 1 MTPF Act Provision	Column 2 Summary of Provision	Column 3 Delegates	Column 4 Conditions or Limitations
<p>Sections 232, 233, 234</p>	<p>The project authority may exercise the following project functions in relation to unnotified utility infrastructure:</p> <ul style="list-style-type: none"> • section 232: give written notice to utilities of the project authority's intention to remove, relocate or protect the infrastructure (as the case may be), and require the utility to agree to the relevant works or carry out the works itself; • section 233: if the project authority does not receive a response or the utility does not agree to the relevant works specified in a notice provided under section 232 of the MTPF Act, remove, relocate or carry out works in relation to utility infrastructure, and give the utility an estimate of costs for which the utility is liable for; and • section 234: notify the relevant utility of any damage caused to unnotified utility infrastructure, and undertake the applicable protection, relocation or removal activities in respect of utility infrastructure (including, if an emergency situation occurs, taking all reasonable steps to end the emergency). 	<ul style="list-style-type: none"> • Director General, MTIA • Chief Executive Officer, MRPV • Director, Commercial & Legal, MRPV <p>and the following class of positions:</p> <ul style="list-style-type: none"> • Director, Delivery, MRPV • Program Director, MRPV • Project Director, MRPV 	

LACA			
Column 1 LACA Provision	Column 2 Summary of Provision	Column 3 Delegates	Column 4 Conditions or Limitations
Section 74 (as modified by section 118(5) of the MTPF Act)	<p>The project authority may, or may authorise another person to:</p> <ul style="list-style-type: none"> enter and remain upon any land (with assistants, vehicles, machinery or equipment); affix or establish any trigonometric stations, survey pegs, marks or poles; undertake flora and fauna surveys, and archaeological investigations; and dig or bore land, and take samples of soil, rock, ground water or minerals. 	<ul style="list-style-type: none"> Director General, MTIA Chief Executive Officer, MRPV Director, Commercial & Legal, MRPV Director, Transport Property, DOT <p>and the following class of positions:</p> <ul style="list-style-type: none"> Director, Delivery, MRPV 	<p>To be exercised by the Director, Transport Property, DOT, unless this is not practicable.</p>
Section 75 (as modified by section 119 of the MTPF Act)	<p>The project authority may, or may authorise another person to enter upon and occupy any land for the purposes:</p> <ul style="list-style-type: none"> digging and taking from the land any clay, stone, gravel, earth or other substance; depositing any material on the land; making cuttings or excavations; taking timber from the land; making and using roads on the land; manufacturing on the land any materials required; demolishing structures (other than places of residence or business); carrying out works on drainage channels, streams or other waterways, or works relating to the diversion of drainage channels, streams or other waterways; or erecting temporary workshops, sheds and buildings. 	<ul style="list-style-type: none"> Director General, MTIA Chief Executive Officer, MRPV Director, Commercial & Legal, MRPV Director, Transport Property, DOT <p>and the following class of positions:</p> <ul style="list-style-type: none"> Director, Delivery, MRPV 	<p>To be exercised by the Director, Transport Property, DOT, unless this is not practicable.</p>

**Major Transport Projects Facilitation Act 2009, Transport Integration Act 2010 and
Land Acquisition and Compensation Act 1986**

INSTRUMENT OF DELEGATION BY SECRETARY

HALLAM NORTH ROAD UPGRADE

I, Paul Younis, Secretary to the Department of Transport (**Secretary**) as project authority of the Hallam North Road Upgrade project (**Project**), a declared project for which designation of the project area in accordance with Part 4 of the **Major Transport Projects Facilitation Act 2009** (Vic.) (**MTPF Act**) occurred on 27 March 2020, and as project authority being also:

- taken to be specified as a determining referral authority in the Casey Planning Scheme under the **Planning and Environment Act 1987** (Vic.) (**Planning and Environment Act 1987**) by operation of section 102A of the MTPF Act (**determining referral authority**); and
- the Authority for the purpose of the **Land Acquisition and Compensation Act 1986** (Vic.) (**LACA**) as applied by section 113 of the MTPF Act (**Authority**) –

in exercise of the powers vested in me under section 104 of the MTPF Act, section 39 of the **Transport Integration Act 2010** and any and all other enabling powers, hereby delegate to the person(s) from time to time employed within the Department of Transport (**DOT**) (which includes the Major Transport Infrastructure Authority, the administrative office existing in relation to DOT that is responsible for delivery of the Project (**MTIA**) and occupying the positions specified in Column 3 of the Schedule to this instrument (each a **Delegate**) such of:

- the project functions and powers conferred on me under the MTPF Act in respect of the Project;
- my powers, duties and functions as determining referral authority in relation to land in the project area; and
- my powers and functions as the Authority –

as are specified for the Delegate in Column 1 and summarised in Column 2 of the Schedule to this instrument, subject to the following conditions and limitations:

17. any condition or limitation that is specified in Column 4 of the Schedule to this instrument with respect to a power, duty or function that is specified in Column 1 of the Schedule to this instrument; and
18. the condition that the power, duty or function may only be exercised for the purpose of the Project.

If the Delegate considers that a project function is one that, in the particular circumstances, requires referral to the Secretary, then before exercising the project function the Delegate should inform and consult with the Secretary.

In the interpretation of this instrument, the summary of a provision set out in Column 2 of the Schedule to this instrument is for convenience only and, unless a contrary intention appears, does not amend, substitute or delete any part of a provision of the MTPF Act or LACA set out in Column 1 of the Schedule to this instrument or otherwise affect the scope or effect of the power, duty or function delegated.

A Delegate is not authorised to delegate or sub-delegate any power delegated under this instrument.

This delegation will remain valid until it is revoked.

The delegation I signed on 23 April 2020 delegating to persons employed within DOT certain powers, duties and functions in respect of the Project, is hereby revoked.

Dated 2 September 2020

PAUL YOUNIS
Secretary to the Department of Transport

SCHEDULE

MTPF Act			
Column 1 MTPF Act Provision	Column 2 Summary of Provision	Column 3 Delegates	Column 4 Conditions or Limitations
Section 96	The project authority may request the Planning Minister to vary the project area for the approved project.	<ul style="list-style-type: none"> • Director General, MTIA • Chief Executive Officer, Major Road Projects Victoria (MRPV) • Director, Commercial & Legal, MRPV 	
Section 101	<p>The project authority may exercise the project authority's functions, summarised as follows:</p> <ul style="list-style-type: none"> • section 101(a): facilitating development of the approved project; • sections 101(b), (c): evaluating submissions from and negotiating with interested parties; • sections 101(d), (e), (f): making recommendations in relation to, and entering and administering contractual arrangements for, development or delivery of the approved project; • sections 101(g), (h), (i): facilitating and coordinating consultations, and negotiating and entering into arrangements, and coordinating, with statutory authorities, agencies of the State and other bodies or persons involved in, or affected by, development or operation of the approved project; • section 101(i): making recommendations to the Project Minister in relation to facilitating the approved project; • section 101(j): ensuring that agreements and arrangements between the State and any other person for, or relating to, the development or delivery of the approved project are performed in accordance with their terms; • section 101(k): commissioning transport infrastructure that is developed as part of the approved project; • section 101(l): undertaking any other functions conferred on the project authority under the MTPF Act or any other Act. 	<ul style="list-style-type: none"> • Director General, MTIA • Chief Executive Officer, MRPV • Director, Commercial & Legal, MRPV <p>and the following class of positions:</p> <ul style="list-style-type: none"> • Director, Delivery, MRPV 	

MTPF Act	Column 2 Summary of Provision	Column 3 Delegates	Column 4 Conditions or Limitations
Section 102	<p>For the purpose of performing its functions, and in addition to all other powers conferred on it by or under any other Act or law, exercising:</p> <ul style="list-style-type: none"> • section 102(1): a specified project power or power conferred on it by or under the MTPF Act; and • Section 102(2): do all other things necessary or convenient to be done for, or in connection with, or as incidental to, the performance of project functions under the MTPF Act. 	<ul style="list-style-type: none"> • Director General, MTIA • Chief Executive Officer, MRPV • Director, Commercial & Legal, MRPV • Director, Transport Property, DOT <p>and the following class of positions:</p> <ul style="list-style-type: none"> • Director, Delivery, MRPV 	
Section 102A	<p>The project authority for an approved project is taken to be specified as a determining referral authority in any planning scheme under the Planning and Environment Act.</p>	<ul style="list-style-type: none"> • Director General, MTIA • Chief Executive Officer, MRPV • Director, Commercial and Legal, MRPV <p>and the following class of positions:</p> <ul style="list-style-type: none"> • Director, Delivery, MRPV • Program Director, MRPV • Project Director, MRPV 	
Section 110	<p>On completion of an approved project, the project authority must notify the Project Minister of the project's completion.</p>	<ul style="list-style-type: none"> • Director General, MTIA • Chief Executive Officer, MRPV 	
Section 112	<p>The project authority may acquire an interest in land in the project area by agreement or by a compulsory process for the purposes of an approved project or any purpose connected with the approved project.</p>	<ul style="list-style-type: none"> • Director, Transport Property, DOT • Director General, MTIA • Chief Executive Officer, MRPV <p>and the following class of positions:</p> <ul style="list-style-type: none"> • Director, Delivery, MRPV 	<p>To be exercised by the Director, Transport Property, DOT, unless this is not practicable.</p> <p>Before acquiring an interest in any land, the delegate must give the Secretary particulars of the land and obtain the Secretary's approval in writing for the acquisition of that land.</p>

MTPF Act			
Column 1 MTPF Act Provision	Column 2 Summary of Provision	Column 3 Delegates	Column 4 Conditions or Limitations
Section 120(4), 120(5)	<p>The project authority must:</p> <ul style="list-style-type: none"> section 120(4): make an offer for the payment of rent to the owner of the land for the authority's occupation of that land; and section 120(5): if an amount of rent to be paid is not agreed upon, notify the Valuer-General in writing of any disagreement with an owner of land as to the amount of rent to be paid. 	<ul style="list-style-type: none"> Director General, MTIA Chief Executive Officer, MRPV Director, Transport Property, DOT <p>and the following class of positions:</p> <ul style="list-style-type: none"> Director, Delivery, MRPV 	
Section 121	<p>The project authority must:</p> <ul style="list-style-type: none"> give the owner of land a condition report; negotiate the contents of the condition report should the owner disagree; and failing which, notify the Valuer General of a dispute under this section. 	<ul style="list-style-type: none"> Director General, MTIA Chief Executive Officer, MRPV Director, Transport Property, DOT <p>and the following class of positions:</p> <ul style="list-style-type: none"> Director, Delivery, MRPV Program Director, MRPV Project Director, MRPV 	
Section 123	<p>A project authority may transfer a building or structure in full or in part settlement of any compensation that the project authority is liable to pay.</p>	<ul style="list-style-type: none"> Director General, MTIA Chief Executive Officer, MRPV Director, Transport Property, DOT 	
Section 124	<p>If a project authority acquires compulsorily under Division 1 of Part 6 to the MTPF Act part of a parcel of land owned by a person, the project authority may require that person to take as compensation land that adjoins the part of the parcel that was not acquired and that is owned by the project authority or is surplus land.</p>	<ul style="list-style-type: none"> Director General, MTIA Chief Executive Officer, MRPV Director, Transport Property, DOT 	

MTPF Act	Column 2 Summary of Provision	Column 3 Delegates	Column 4 Conditions or Limitations
<p>Column 1 MTPF Act Provision</p> <p>Sections 127, 129</p>	<p>The project authority is authorised to:</p> <ul style="list-style-type: none"> • section 127: compulsorily acquire a native title right or interest in land in the project area for the purposes of an approved project or any purpose connected with an approved project; • section 129: comply with relevant procedures under the Native Title Act 1993 (Vic.) for acquisition of native title rights and interests. 	<ul style="list-style-type: none"> • Director General, MTIA • Chief Executive Officer, MRPV • Director, Transport Property, DOT 	<p>To be exercised by the Director, Transport Property, DOT, unless this is not practicable.</p> <p>Before acquiring a native title right or interest in land in the project area, the delegate must give the Secretary particulars of the land and obtain the Secretary's approval in writing for the acquisition of that right or interest.</p>
<p>Section 133</p>	<p>The project authority may purchase land outside the project area for the purposes of an approved project, or preservation, restoration or provision of native habitat.</p>	<ul style="list-style-type: none"> • Director General, MTIA • Chief Executive Officer, MRPV • Director, Transport Property, DOT <p>and the following class of positions:</p> <ul style="list-style-type: none"> • Director, Delivery, MRPV 	<p>To be exercised by the Director, Transport Property, DOT, unless this is not practicable.</p> <p>Before purchasing any land outside the project area, the delegate must give the Secretary particulars of the land and obtain the Secretary's approval in writing for the purchase of that land.</p>
<p>Section 137B</p>	<p>The project authority may request the consent of the Project Minister to the surrender to the Crown of land held in fee simple if the land is intended to form part of a lease of land under section 177 of the MTPF Act.</p>	<ul style="list-style-type: none"> • Director General, MTIA • Chief Executive Officer, MRPV • Director, Transport Property, DOT 	
<p>Section 143</p>	<p>The project authority must notify the Minister administering the Crown Land (Reserves) Act 1978 (Vic.) of reservation of land under Subdivision 1, 2 or 2A or Division 6 of the MTPF Act.</p>	<ul style="list-style-type: none"> • Director General, MTIA • Chief Executive Officer, MRPV • Director, Transport Property, DOT 	
<p>Section 147</p>	<p>The project authority may transfer a building or structure from project land or project authority-owned land or Council-owned land, to other land owned by the Council as compensation.</p>	<ul style="list-style-type: none"> • Director General, MTIA • Chief Executive Officer, MRPV • Director, Transport Property, DOT 	

MTPF Act			
Column 1 MTPF Act Provision	Column 2 Summary of Provision	Column 3 Delegates	Column 4 Conditions or Limitations
Section 148	The project authority may require that adjoining land is provided as compensation to Council for land acquired compulsorily.	<ul style="list-style-type: none"> • Director General, MTIA • Chief Executive Officer, MRPV • Director, Transport Property, DOT 	
Section 151	The project authority may enter into possession of project land.	<ul style="list-style-type: none"> • Director General, MTIA • Chief Executive Officer, MRPV • Director, Transport Property, DOT <p>and the following class of positions:</p> <ul style="list-style-type: none"> • Director, Delivery, MRPV 	
Section 152	The project authority must diligently endeavour to obtain agreement with the occupier of project land on terms for entry into possession of the land.	<ul style="list-style-type: none"> • Director General, MTIA • Chief Executive Officer, MRPV • Director, Transport Property, DOT <p>and the following class of positions:</p> <ul style="list-style-type: none"> • Director, Delivery, MRPV • Program Director, MRPV • Project Director, MRPV 	
Section 155(1)	The project authority may enter an agreement in relation to the time of entry into possession of project land, with the consent of the Project Minister.	<ul style="list-style-type: none"> • Coordinator General, MTIA • Chief Executive Officer, MRPV • Director, Transport Property, DOT <p>and the following class of positions:</p> <ul style="list-style-type: none"> • Director, Delivery, MRPV • Program Director, MRPV • Project Director, MRPV 	

MTPF Act			
Column 1 MTPF Act Provision	Column 2 Summary of Provision	Column 3 Delegates	Column 4 Conditions or Limitations
Section 155(3)	The project authority must serve a copy of the certificate provided under section 155(1)(a) of the MTPF Act on the occupier.	<ul style="list-style-type: none"> • Director General, MTIA • Chief Executive Officer, MRPV • Director, Transport Property, DOT <p>and the following class of positions:</p> <ul style="list-style-type: none"> • Director, Delivery, MRPV • Program Director, MRPV • Project Director, MRPV 	
Section 156	The occupation period for project land may be extended by agreement between the project authority and the occupier of the project land.	<ul style="list-style-type: none"> • Director General, MTIA • Chief Executive Officer, MRPV • Director, Transport Property, DOT <p>and the following class of positions:</p> <ul style="list-style-type: none"> • Director, Delivery, MRPV • Program Director, MRPV • Project Director, MRPV 	
Section 158	Rent payable under the applicable Subdivision of the MTPF Act may be recovered as a debt due to the project authority in any court of competent jurisdiction.	<ul style="list-style-type: none"> • Director General, MTIA • Chief Executive Officer, MRPV • Director, Transport Property, DOT • Director, Commercial & Legal, MRPV 	
Section 159	The project authority may issue a warrant to the sheriff where entitled under the applicable Division to enter into possession of project land and an occupier of project land refuses to give up possession of the land or hinders entry to that land.	<ul style="list-style-type: none"> • Director General, MTIA • Chief Executive Officer, MRPV • Director, Commercial & Legal, MRPV 	

MTPF Act			
Column 1 MTPF Act Provision	Column 2 Summary of Provision	Column 3 Delegates	Column 4 Conditions or Limitations
Section 167	<p>The project authority:</p> <ul style="list-style-type: none"> • section 167(1): may carry out or authorise works on public land inside or outside the project area for the purposes of the approved project; and • section 167(2): must notify any Minister, public authority or Council that owns or manages the public land prior to works being carried out or performed. 	<ul style="list-style-type: none"> • Director General, MTIA • Chief Executive Officer, MRPV • Director, Commercial & Legal, MRPV <p>and the following class of positions:</p> <ul style="list-style-type: none"> • Director, Delivery, MRPV • Program Director, MRPV • Project Director, MRPV 	
Section 168A	<p>The project authority may carry out or authorise associated works where an applicable approval has been granted for those works or is not required.</p>	<ul style="list-style-type: none"> • Director General, MTIA • Chief Executive Officer, MRPV • Director, Commercial & Legal, MRPV <p>and the following class of positions:</p> <ul style="list-style-type: none"> • Director, Delivery, MRPV • Program Director, MRPV • Project Director, MRPV 	
Section 170	<p>The project authority may use or authorise use of any Crown land for the purposes of an approved project.</p>	<ul style="list-style-type: none"> • Director General, MTIA • Chief Executive Officer, MRPV • Director, Commercial & Legal, MRPV <p>and the following class of positions:</p> <ul style="list-style-type: none"> • Director, Delivery, MRPV • Program Director, MRPV • Project Director, MRPV 	

MTPF Act			
Column 1 MTPF Act Provision	Column 2 Summary of Provision	Column 3 Delegates	Column 4 Conditions or Limitations
Section 171	The project authority may carry out or authorise works on any land within an easement acquired under the applicable Part of the MTPF Act.	<ul style="list-style-type: none"> • Director General, MTIA • Chief Executive Officer, MRPV • Director, Commercial & Legal, MRPV <p>and the following class of positions:</p> <ul style="list-style-type: none"> • Director, Delivery, MRPV • Program Director, MRPV • Project Director, MRPV 	
Section 171A	The project authority may transfer to a utility any easement acquired over project land for the purposes of relocating utility infrastructure as a result of an approved project.	<ul style="list-style-type: none"> • Director General, MTIA • Chief Executive Officer, MRPV • Director, Transport Property, DOT • Director, Commercial & Legal, MRPV <p>and the following class of positions:</p> <ul style="list-style-type: none"> • Director, Delivery, MRPV • Program Director, MRPV • Project Director, MRPV 	
Section 173	The project authority may issue a licence to any person to enter and use all or any part of project land that is Crown land, or land that the project authority holds in fee simple, for the purposes of the approved project.	<ul style="list-style-type: none"> • Director General, MTIA • Chief Executive Officer, MRPV • Director, Transport Property, DOT <p>and the following class of positions:</p> <ul style="list-style-type: none"> • Director, Delivery, MRPV • Program Director, MRPV • Project Director, MRPV 	
Section 184	The project authority may enter into an agreement concerning the use or development of surplus land upon or in anticipation of disposing of the whole of its interest in the land.	<ul style="list-style-type: none"> • Director General, MTIA • Chief Executive Officer, MRPV • Director, Transport Property, DOT 	

MTPF Act			
Column 1 MTPF Act Provision	Column 2 Summary of Provision	Column 3 Delegates	Column 4 Conditions or Limitations
Section 185	The project authority may sell, lease or licence any surplus land held in fee simple.	<ul style="list-style-type: none"> • Director General, MTIA • Chief Executive Officer, MRPV • Director, Transport Property, DOT 	
Section 186	<p>The project authority may:</p> <ul style="list-style-type: none"> • open, discontinue, construct, relocate or realign roads, and close any road to traffic; • carry out improvements to roads in the project area; • construct roads over or under roads constructed or to be constructed in the project area; • construct any road in the project area over or under any other roads; and • cause fences, posts, or other structures to be erected along any road constructed or to be constructed in the project area, or across any entrance, approach or means of access to, any road constructed or to be constructed in the project area. 	<ul style="list-style-type: none"> • Director General, MTIA • Chief Executive Officer, MRPV • Director, Commercial & Legal, MRPV <p>and the following class of positions:</p> <ul style="list-style-type: none"> • Director, Delivery, MRPV • Program Director, MRPV • Project Director, MRPV 	
Section 187	The project authority must advise the coordinating road authority before exercising any power under section 186.	<ul style="list-style-type: none"> • Director General, MTIA • Chief Executive Officer, MRPV • Director, Commercial & Legal, MRPV <p>and the following class of positions:</p> <ul style="list-style-type: none"> • Director, Delivery, MRPV • Program Director, MRPV • Project Director, MRPV 	

MTPF Act			
Column 1 MTPF Act Provision	Column 2 Summary of Provision	Column 3 Delegates	Column 4 Conditions or Limitations
Section 189	The project authority must cause notice of a decision under section 186 to be published in the Government Gazette and in a newspaper being circulated throughout the area affected by the decision.	<ul style="list-style-type: none"> • Director General, MTIA • Chief Executive Officer, MRPV • Director, Commercial & Legal, MRPV <p>and the following class of positions:</p> <ul style="list-style-type: none"> • Director, Delivery, MRPV • Program Director, MRPV • Project Director, MRPV 	
Section 190	The project authority may temporarily close a road to traffic for the purposes of an approved project if considered necessary to do so for works on the road or neighbouring land to be carried out.	<ul style="list-style-type: none"> • Director General, MTIA • Chief Executive Officer, MRPV • Director, Commercial & Legal, MRPV <p>and the following class of positions:</p> <ul style="list-style-type: none"> • Director, Delivery, MRPV • Program Director, MRPV • Project Director, MRPV 	
Section 196	The project authority may establish or cause to be established as a 'restricted access area' a the project area or land temporarily occupied under section 75 of the Land Acquisition Compensation Act 1986 by use of fencing, barriers, other temporary or permanent means of physical demarcation or signage on or in proximity to the area.	<ul style="list-style-type: none"> • Director General, MTIA • Chief Executive Officer, MRPV • Director, Commercial & Legal, MRPV <p>and the following class of positions:</p> <ul style="list-style-type: none"> • Director, Delivery, MRPV • Program Director, MRPV • Project Director, MRPV 	

MTPF Act			
Column 1 MTPF Act Provision	Column 2 Summary of Provision	Column 3 Delegates	Column 4 Conditions or Limitations
Section 198	The project authority must issue identity cards to authorised officers appointed for the purposes of exercising functions in respect of restricted access areas.	<ul style="list-style-type: none"> • Director General, MTIA • Chief Executive Officer, MRPV • Director, Commercial & Legal, MRPV <p>and the following class of positions:</p> <ul style="list-style-type: none"> • Director, Delivery, MRPV • Program Director, MRPV • Project Director, MRPV 	
Section 199	The project authority may, by issuing a certificate or making a declaration, authorise a person or class of person to enter and remain in a restricted access area for the purposes of preparing or conducting activities for the purposes of an approved project or carrying out ancillary activities.	<ul style="list-style-type: none"> • Director General, MTIA • Chief Executive Officer, MRPV • Director, Commercial & Legal, MRPV <p>and the following class of positions:</p> <ul style="list-style-type: none"> • Director, Delivery, MRPV • Program Director, MRPV • Project Director, MRPV 	
Sections 200, 201	The project authority may warn any person (other than owner of land or a person authorised in writing by the owner or under the MTPF Act) to leave any part of the restricted access area under the applicable Division of the MTPF Act.	<ul style="list-style-type: none"> • Director General, MTIA • Chief Executive Officer, MRPV • Director, Commercial & Legal, MRPV <p>and the following class of positions:</p> <ul style="list-style-type: none"> • Director, Delivery, MRPV • Program Director, MRPV • Project Director, MRPV 	

MTPF Act			
Column 1 MTPF Act Provision	Column 2 Summary of Provision	Column 3 Delegates	Column 4 Conditions or Limitations
Sections 211, 211A	<p>The project authority:</p> <ul style="list-style-type: none"> • section 211: must take all reasonable steps to identify all utility infrastructure, and every utility that owns such infrastructure, that may be affected by the development of the declared project; and • section 211A: may give a notice to a utility identified under section 211 of the MTPF Act requiring it state whether it owns, operates or controls the relevant utility infrastructure in the specified area, describe the nature of that infrastructure and its location, and provide plans showing the location of that infrastructure. 	<ul style="list-style-type: none"> • Director General, MTIA • Chief Executive Officer, MRPV • Director, Commercial & Legal, MRPV <p>and the following class of positions:</p> <ul style="list-style-type: none"> • Director, Delivery, MRPV • Program Director, MRPV • Project Director, MRPV 	
Section 213	<p>Following the applicable notice period, the project authority may give written notice to a utility of an intention to commence negotiations with the utility for the purpose of entering a utility agreement.</p>	<ul style="list-style-type: none"> • Director General, MTIA • Chief Executive Officer, MRPV • Director, Commercial & Legal, MRPV <p>and the following class of positions:</p> <ul style="list-style-type: none"> • Director, Delivery, MRPV • Program Director, MRPV • Project Director, MRPV 	
Section 214	<p>The project authority (and the relevant utility) must use all reasonable endeavours to negotiate a utility agreement within 50 business days after notice is given under section 213 of the MTPF Act.</p>	<ul style="list-style-type: none"> • Director General, MTIA • Chief Executive Officer, MRPV • Director, Commercial & Legal, MRPV <p>and the following class of positions:</p> <ul style="list-style-type: none"> • Director, Delivery, MRPV • Program Director, MRPV • Project Director, MRPV 	

MTPF Act	Column 1 MTPF Act Provision	Column 2 Summary of Provision	Column 3 Delegates	Column 4 Conditions or Limitations
Section 215		<p>The project authority must give written notice to the Project Minister and Utility Minister for the utility if a utility agreement is not entered into between the parties within the applicable 50 business day period.</p>	<ul style="list-style-type: none"> • Director General, MTIA • Chief Executive Officer, MRPV • Director, Commercial & Legal, MRPV <p>and the following class of positions:</p> <ul style="list-style-type: none"> • Director, Delivery, MRPV • Program Director, MRPV • Project Director, MRPV 	
Sections 216, 217, 218, 224, 225, 227		<p>The project authority may exercise the following project functions for dispute resolution and termination in relation to a utility agreement:</p> <ul style="list-style-type: none"> • section 216: give notice to the other party that a dispute exists; • section 217: use reasonable endeavours to agree on an expert for resolving the dispute; • section 218: inform the Project Minister if the parties have agreed on an expert to be appointed, or otherwise if there has been no such agreement; • section 224: provide a draft utility agreement that identifies the applicable matters in relation to which the parties do not agree; • section 225: make a submission to the expert in relation to the dispute; and • section 227: agree to termination or revocation of a utility agreement approved in accordance with section 226(4) of the MTPF Act. 	<ul style="list-style-type: none"> • Director General, MTIA • Chief Executive Officer, MRPV • Director, Commercial & Legal, MRPV <p>and the following class of positions:</p> <ul style="list-style-type: none"> • Director, Delivery, MRPV • Program Director, MRPV • Project Director, MRPV 	

MTPF Act			
Column 1 MTPF Act Provision	Column 2 Summary of Provision	Column 3 Delegates	Column 4 Conditions or Limitations
Sections 232, 233, 234	<p>The project authority may exercise the following project functions in relation to unnotified utility infrastructure:</p> <ul style="list-style-type: none"> • section 232: give written notice to utilities of the project authority's intention to remove, relocate or protect the infrastructure (as the case may be), and require the utility to agree to the relevant works or carry out the works itself; • section 233: if the project authority does not receive a response or the utility does not agree to the relevant works specified in a notice provided under section 232 of the MTPF Act, remove, relocate or carry out works in relation to utility infrastructure, and give the utility an estimate of costs for which the utility is liable for; and • section 234: notify the relevant utility of any damage caused to unnotified utility infrastructure, and undertake the applicable protection, relocation or removal activities in respect of utility infrastructure (including, if an emergency situation occurs, taking all reasonable steps to end the emergency). 	<ul style="list-style-type: none"> • Director General, MTIA • Chief Executive Officer, MRPV • Director, Commercial & Legal, MRPV <p>and the following class of positions:</p> <ul style="list-style-type: none"> • Director, Delivery, MRPV • Program Director, MRPV • Project Director, MRPV 	

LACA			
Column 1 LACA Provision	Column 2 Summary of Provision	Column 3 Delegates	Column 4 Conditions or Limitations
Section 74 (as modified by section 118(5) of the MTPF Act)	<p>The project authority may, or may authorise another person to:</p> <ul style="list-style-type: none"> • enter and remain upon any land (with assistants, vehicles, machinery or equipment); • affix or establish any trigonometric stations, survey pegs, marks or poles; • undertake flora and fauna surveys, and archaeological investigations; and • dig or bore land, and take samples of soil, rock, ground water or minerals. 	<ul style="list-style-type: none"> • Director General, MTIA • Chief Executive Officer, MRPV • Director, Commercial & Legal, MRPV • Director, Transport Property, DOT <p>and the following class of positions:</p> <ul style="list-style-type: none"> • Director, Delivery, MRPV 	<p>To be exercised by the Director, Transport Property, DOT, unless this is not practicable.</p>
Section 75 (as modified by section 119 of the MTPF Act)	<p>The project authority may, or may authorise another person to enter upon and occupy any land for the purposes:</p> <ul style="list-style-type: none"> • digging and taking from the land any clay, stone, gravel, earth or other substance; • depositing any material on the land; • making cuttings or excavations; • taking timber from the land; • making and using roads on the land; • manufacturing on the land any materials required; • demolishing structures (other than places of residence or business); • carrying out works on drainage channels, streams or other waterways, or works relating to the diversion of drainage channels, streams or other waterways; or • erecting temporary workshops, sheds and buildings. 	<ul style="list-style-type: none"> • Director General, MTIA • Chief Executive Officer, MRPV • Director, Commercial & Legal, MRPV • Director, Transport Property, DOT <p>and the following class of positions:</p> <ul style="list-style-type: none"> • Director, Delivery, MRPV 	<p>To be exercised by the Director, Transport Property, DOT, unless this is not practicable.</p>

**Major Transport Projects Facilitation Act 2009, Transport Integration Act 2010 and
Land Acquisition and Compensation Act 1986**

INSTRUMENT OF DELEGATION BY SECRETARY

LATHAMS ROAD UPGRADE

I, Paul Younis, Secretary to the Department of Transport (**Secretary**) as project authority of the Lathams Road Upgrade project (**Project**), a declared project for which designation of the project area in accordance with Part 4 of the **Major Transport Projects Facilitation Act 2009** (Vic.) (**MTPF Act**) occurred on 27 March 2020, and as project authority being also:

- taken to be specified as a determining referral authority in the Frankston Planning Scheme under the **Planning and Environment Act 1987** (Vic.) (**Planning and Environment Act 1987**) by operation of section 102A of the MTPF Act (**determining referral authority**); and
- the Authority for the purpose of the **Land Acquisition and Compensation Act 1986** (Vic.) (**LACA**) as applied by section 113 of the MTPF Act (**Authority**) –

in exercise of the powers vested in me under section 104 of the MTPF Act, section 39 of the **Transport Integration Act 2010** and any and all other enabling powers, hereby delegate to the person(s) from time to time employed within the Department of Transport (**DOT**) (which includes the Major Transport Infrastructure Authority, the administrative office existing in relation to DOT that is responsible for delivery of the Project (**MTIA**) and occupying the positions specified in Column 3 of the Schedule to this instrument (each a **Delegate**) such of:

- the project functions and powers conferred on me under the MTPF Act in respect of the Project;
- my powers, duties and functions as determining referral authority in relation to land in the project area; and
- my powers and functions as the Authority –

as are specified for the Delegate in Column 1 and summarised in Column 2 of the Schedule to this instrument, subject to the following conditions and limitations:

15. any condition or limitation that is specified in Column 4 of the Schedule to this instrument with respect to a power, duty or function that is specified in Column 1 of the Schedule to this instrument; and
16. the condition that the power, duty or function may only be exercised for the purpose of the Project.

If the Delegate considers that a project function is one that, in the particular circumstances, requires referral to the Secretary, then before exercising the project function the Delegate should inform and consult with the Secretary.

In the interpretation of this instrument, the summary of a provision set out in Column 2 of the Schedule to this instrument is for convenience only and, unless a contrary intention appears, does not amend, substitute or delete any part of a provision of the MTPF Act or LACA set out in Column 1 of the Schedule to this instrument or otherwise affect the scope or effect of the power, duty or function delegated.

A Delegate is not authorised to delegate or sub-delegate any power delegated under this instrument.

This delegation will remain valid until it is revoked.

The delegation I signed on 23 April 2020 delegating to persons employed within DOT certain powers, duties and functions in respect of the Project, is hereby revoked.

Dated 2 September 2020

PAUL YOUNIS
Secretary to the Department of Transport

SCHEDULE

MTPF Act			
Column 1 MTPF Act Provision	Column 2 Summary of Provision	Column 3 Delegates	Column 4 Conditions or Limitations
Section 96	The project authority may request the Planning Minister to vary the project area for the approved project.	<ul style="list-style-type: none"> • Director General, MTIA • Chief Executive Officer, Major Road Projects Victoria (MRPV) • Director, Commercial & Legal, MRPV 	
Section 101	<p>The project authority may exercise the project authority's functions, summarised as follows:</p> <ul style="list-style-type: none"> • section 101(a): facilitating development of the approved project; • sections 101(b), (c): evaluating submissions from and negotiating with interested parties; • sections 101(d), (e), (f): making recommendations in relation to, and entering and administering contractual arrangements for, development or delivery of the approved project; • sections 101(g), (h), (i): facilitating and coordinating consultations, and negotiating and entering into arrangements, and coordinating, with statutory authorities, agencies of the State and other bodies or persons involved in, or affected by, development or operation of the approved project; • section 101(i): making recommendations to the Project Minister in relation to facilitating the approved project; • section 101(j): ensuring that agreements and arrangements between the State and any other person for, or relating to, the development or delivery of the approved project are performed in accordance with their terms; • section 101(k): commissioning transport infrastructure that is developed as part of the approved project; • section 101(l): undertaking any other functions conferred on the project authority under the MTPF Act or any other Act. 	<ul style="list-style-type: none"> • Director General, MTIA • Chief Executive Officer, MRPV • Director, Commercial & Legal, MRPV <p>and the following class of positions:</p> <ul style="list-style-type: none"> • Director, Delivery, MRPV 	

MTPF Act	Column 2 Summary of Provision	Column 3 Delegates	Column 4 Conditions or Limitations
Section 102	<p>For the purpose of performing its functions, and in addition to all other powers conferred on it by or under any other Act or law, exercising:</p> <ul style="list-style-type: none"> • section 102(1): a specified project power or power conferred on it by or under the MTPF Act; and • Section 102(2): do all other things necessary or convenient to be done for, or in connection with, or as incidental to, the performance of project functions under the MTPF Act. 	<ul style="list-style-type: none"> • Director General, MTIA • Chief Executive Officer, MRPV • Director, Commercial & Legal, MRPV • Director, Transport Property, DOT <p>and the following class of positions:</p> <ul style="list-style-type: none"> • Director, Delivery, MRPV 	
Section 102A	<p>The project authority for an approved project is taken to be specified as a determining referral authority in any planning scheme under the Planning and Environment Act.</p>	<ul style="list-style-type: none"> • Director General, MTIA • Chief Executive Officer, MRPV • Director, Commercial and Legal, MRPV <p>and the following class of positions:</p> <ul style="list-style-type: none"> • Director, Delivery, MRPV • Program Director, MRPV • Project Director, MRPV 	
Section 110	<p>On completion of an approved project, the project authority must notify the Project Minister of the project's completion.</p>	<ul style="list-style-type: none"> • Director General, MTIA • Chief Executive Officer, MRPV 	
Section 112	<p>The project authority may acquire an interest in land in the project area by agreement or by a compulsory process for the purposes of an approved project or any purpose connected with the approved project.</p>	<ul style="list-style-type: none"> • Director, Transport Property, DOT • Director General, MTIA • Chief Executive Officer, MRPV <p>and the following class of positions:</p> <ul style="list-style-type: none"> • Director, Delivery, MRPV 	<p>To be exercised by the Director, Transport Property, DOT, unless this is not practicable.</p> <p>Before acquiring an interest in any land, the delegate must give the Secretary particulars of the land and obtain the Secretary's approval in writing for the acquisition of that land.</p>

MTPF Act			
Column 1 MTPF Act Provision	Column 2 Summary of Provision	Column 3 Delegates	Column 4 Conditions or Limitations
Section 120(4), 120(5)	<p>The project authority must:</p> <ul style="list-style-type: none"> section 120(4): make an offer for the payment of rent to the owner of the land for the authority's occupation of that land; and section 120(5): if an amount of rent to be paid is not agreed upon, notify the Valuer-General in writing of any disagreement with an owner of land as to the amount of rent to be paid. 	<ul style="list-style-type: none"> Director General, MTIA Chief Executive Officer, MRPV Director, Transport Property, DOT <p>and the following class of positions:</p> <ul style="list-style-type: none"> Director, Delivery, MRPV 	
Section 121	<p>The project authority must:</p> <ul style="list-style-type: none"> give the owner of land a condition report; negotiate the contents of the condition report should the owner disagree; and failing which, notify the Valuer General of a dispute under this section. 	<ul style="list-style-type: none"> Director General, MTIA Chief Executive Officer, MRPV Director, Transport Property, DOT <p>and the following class of positions:</p> <ul style="list-style-type: none"> Director, Delivery, MRPV Program Director, MRPV Project Director, MRPV 	
Section 123	<p>A project authority may transfer a building or structure in full or in part settlement of any compensation that the project authority is liable to pay.</p>	<ul style="list-style-type: none"> Director General, MTIA Chief Executive Officer, MRPV Director, Transport Property, DOT 	
Section 124	<p>If a project authority acquires compulsorily under Division 1 of Part 6 to the MTPF Act part of a parcel of land owned by a person, the project authority may require that person to take as compensation land that adjoins the part of the parcel that was not acquired and that is owned by the project authority or is surplus land.</p>	<ul style="list-style-type: none"> Director General, MTIA Chief Executive Officer, MRPV Director, Transport Property, DOT 	

MTPF Act	Column 2 Summary of Provision	Column 3 Delegates	Column 4 Conditions or Limitations
<p>Column 1 MTPF Act Provision</p> <p>Sections 127, 129</p>	<p>The project authority is authorised to:</p> <ul style="list-style-type: none"> • section 127: compulsorily acquire a native title right or interest in land in the project area for the purposes of an approved project or any purpose connected with an approved project; • section 129: comply with relevant procedures under the Native Title Act 1993 (Vic.) for acquisition of native title rights and interests. 	<ul style="list-style-type: none"> • Director General, MTIA • Chief Executive Officer, MRPV • Director, Transport Property, DOT 	<p>To be exercised by the Director, Transport Property, DOT, unless this is not practicable.</p> <p>Before acquiring a native title right or interest in land in the project area, the delegate must give the Secretary particulars of the land and obtain the Secretary's approval in writing for the acquisition of that right or interest.</p>
<p>Section 133</p>	<p>The project authority may purchase land outside the project area for the purposes of an approved project, or preservation, restoration or provision of native habitat.</p>	<ul style="list-style-type: none"> • Director General, MTIA • Chief Executive Officer, MRPV • Director, Transport Property, DOT <p>and the following class of positions:</p> <ul style="list-style-type: none"> • Director, Delivery, MRPV 	<p>To be exercised by the Director, Transport Property, DOT, unless this is not practicable.</p> <p>Before purchasing any land outside the project area, the delegate must give the Secretary particulars of the land and obtain the Secretary's approval in writing for the purchase of that land.</p>
<p>Section 137B</p>	<p>The project authority may request the consent of the Project Minister to the surrender to the Crown of land held in fee simple if the land is intended to form part of a lease of land under section 177 of the MTPF Act.</p>	<ul style="list-style-type: none"> • Director General, MTIA • Chief Executive Officer, MRPV • Director, Transport Property, DOT 	
<p>Section 143</p>	<p>The project authority must notify the Minister administering the Crown Land (Reserves) Act 1978 (Vic.) of reservation of land under Subdivision 1, 2 or 2A or Division 6 of the MTPF Act.</p>	<ul style="list-style-type: none"> • Director General, MTIA • Chief Executive Officer, MRPV • Director, Transport Property, DOT 	
<p>Section 147</p>	<p>The project authority may transfer a building or structure from project land or project authority-owned land or Council-owned land, to other land owned by the Council as compensation.</p>	<ul style="list-style-type: none"> • Director General, MTIA • Chief Executive Officer, MRPV • Director, Transport Property, DOT 	

MTPF Act			
Column 1 MTPF Act Provision	Column 2 Summary of Provision	Column 3 Delegates	Column 4 Conditions or Limitations
Section 148	The project authority may require that adjoining land is provided as compensation to Council for land acquired compulsorily.	<ul style="list-style-type: none"> • Director General, MTIA • Chief Executive Officer, MRPV • Director, Transport Property, DOT 	
Section 151	The project authority may enter into possession of project land.	<ul style="list-style-type: none"> • Director General, MTIA • Chief Executive Officer, MRPV • Director, Transport Property, DOT <p>and the following class of positions:</p> <ul style="list-style-type: none"> • Director, Delivery, MRPV 	
Section 152	The project authority must diligently endeavour to obtain agreement with the occupier of project land on terms for entry into possession of the land.	<ul style="list-style-type: none"> • Director General, MTIA • Chief Executive Officer, MRPV • Director, Transport Property, DOT <p>and the following class of positions:</p> <ul style="list-style-type: none"> • Director, Delivery, MRPV • Program Director, MRPV • Project Director, MRPV 	
Section 155(1)	The project authority may enter an agreement in relation to the time of entry into possession of project land, with the consent of the Project Minister.	<ul style="list-style-type: none"> • Coordinator General, MTIA • Chief Executive Officer, MRPV • Director, Transport Property, DOT <p>and the following class of positions:</p> <ul style="list-style-type: none"> • Director, Delivery, MRPV • Program Director, MRPV • Project Director, MRPV 	

MTPF Act			
Column 1 MTPF Act Provision	Column 2 Summary of Provision	Column 3 Delegates	Column 4 Conditions or Limitations
Section 155(3)	The project authority must serve a copy of the certificate provided under section 155(1)(a) of the MTPF Act on the occupier.	<ul style="list-style-type: none"> • Director General, MTIA • Chief Executive Officer, MRPV • Director, Transport Property, DOT <p>and the following class of positions:</p> <ul style="list-style-type: none"> • Director, Delivery, MRPV • Program Director, MRPV • Project Director, MRPV 	
Section 156	The occupation period for project land may be extended by agreement between the project authority and the occupier of the project land.	<ul style="list-style-type: none"> • Director General, MTIA • Chief Executive Officer, MRPV • Director, Transport Property, DOT <p>and the following class of positions:</p> <ul style="list-style-type: none"> • Director, Delivery, MRPV • Program Director, MRPV • Project Director, MRPV 	
Section 158	Rent payable under the applicable Subdivision of the MTPF Act may be recovered as a debt due to the project authority in any court of competent jurisdiction.	<ul style="list-style-type: none"> • Director General, MTIA • Chief Executive Officer, MRPV • Director, Transport Property, DOT • Director, Commercial & Legal, MRPV 	
Section 159	The project authority may issue a warrant to the sheriff where entitled under the applicable Division to enter into possession of project land and an occupier of project land refuses to give up possession of the land or hinders entry to that land.	<ul style="list-style-type: none"> • Director General, MTIA • Chief Executive Officer, MRPV • Director, Commercial & Legal, MRPV 	

MTPF Act			
Column 1 MTPF Act Provision	Column 2 Summary of Provision	Column 3 Delegates	Column 4 Conditions or Limitations
Section 167	<p>The project authority:</p> <ul style="list-style-type: none"> • section 167(1): may carry out or authorise works on public land inside or outside the project area for the purposes of the approved project; and • section 167(2): must notify any Minister, public authority or Council that owns or manages the public land prior to works being carried out or performed. 	<ul style="list-style-type: none"> • Director General, MTIA • Chief Executive Officer, MRPV • Director, Commercial & Legal, MRPV <p>and the following class of positions:</p> <ul style="list-style-type: none"> • Director, Delivery, MRPV • Program Director, MRPV • Project Director, MRPV 	
Section 168A	<p>The project authority may carry out or authorise associated works where an applicable approval has been granted for those works or is not required.</p>	<ul style="list-style-type: none"> • Director General, MTIA • Chief Executive Officer, MRPV • Director, Commercial & Legal, MRPV <p>and the following class of positions:</p> <ul style="list-style-type: none"> • Director, Delivery, MRPV • Program Director, MRPV • Project Director, MRPV 	
Section 170	<p>The project authority may use or authorise use of any Crown land for the purposes of an approved project.</p>	<ul style="list-style-type: none"> • Director General, MTIA • Chief Executive Officer, MRPV • Director, Commercial & Legal, MRPV <p>and the following class of positions:</p> <ul style="list-style-type: none"> • Director, Delivery, MRPV • Program Director, MRPV • Project Director, MRPV 	

MTPF Act			
Column 1 MTPF Act Provision	Column 2 Summary of Provision	Column 3 Delegates	Column 4 Conditions or Limitations
Section 171	The project authority may carry out or authorise works on any land within an easement acquired under the applicable Part of the MTPF Act.	<ul style="list-style-type: none"> • Director General, MTIA • Chief Executive Officer, MRPV • Director, Commercial & Legal, MRPV <p>and the following class of positions:</p> <ul style="list-style-type: none"> • Director, Delivery, MRPV • Program Director, MRPV • Project Director, MRPV 	
Section 171A	The project authority may transfer to a utility any easement acquired over project land for the purposes of relocating utility infrastructure as a result of an approved project.	<ul style="list-style-type: none"> • Director General, MTIA • Chief Executive Officer, MRPV • Director, Transport Property, DOT • Director, Commercial & Legal, MRPV <p>and the following class of positions:</p> <ul style="list-style-type: none"> • Director, Delivery, MRPV • Program Director, MRPV • Project Director, MRPV 	
Section 173	The project authority may issue a licence to any person to enter and use all or any part of project land that is Crown land, or land that the project authority holds in fee simple, for the purposes of the approved project.	<ul style="list-style-type: none"> • Director General, MTIA • Chief Executive Officer, MRPV • Director, Transport Property, DOT <p>and the following class of positions:</p> <ul style="list-style-type: none"> • Director, Delivery, MRPV • Program Director, MRPV • Project Director, MRPV 	
Section 184	The project authority may enter into an agreement concerning the use or development of surplus land upon or in anticipation of disposing of the whole of its interest in the land.	<ul style="list-style-type: none"> • Director General, MTIA • Chief Executive Officer, MRPV • Director, Transport Property, DOT 	

MTPF Act	Column 2 Summary of Provision	Column 3 Delegates	Column 4 Conditions or Limitations
<p>Section 185</p> <p>Column 1 MTPF Act Provision</p>	<p>The project authority may sell, lease or licence any surplus land held in fee simple.</p>	<ul style="list-style-type: none"> • Director General, MTIA • Chief Executive Officer, MRPV • Director, Transport Property, DOT 	
<p>Section 186</p>	<p>The project authority may:</p> <ul style="list-style-type: none"> • open, discontinue, construct, relocate or realign roads, and close any road to traffic; • carry out improvements to roads in the project area; • construct roads over or under roads constructed or to be constructed in the project area; • construct any road in the project area over or under any other roads; and • cause fences, posts, or other structures to be erected along any road constructed or to be constructed in the project area, or across any entrance, approach or means of access to, any road constructed or to be constructed in the project area. 	<ul style="list-style-type: none"> • Director General, MTIA • Chief Executive Officer, MRPV • Director, Commercial & Legal, MRPV <p>and the following class of positions:</p> <ul style="list-style-type: none"> • Director, Delivery, MRPV • Program Director, MRPV • Project Director, MRPV 	
<p>Section 187</p>	<p>The project authority must advise the coordinating road authority before exercising any power under section 186.</p>	<ul style="list-style-type: none"> • Director General, MTIA • Chief Executive Officer, MRPV • Director, Commercial & Legal, MRPV <p>and the following class of positions:</p> <ul style="list-style-type: none"> • Director, Delivery, MRPV • Program Director, MRPV • Project Director, MRPV 	

MTPF Act			
Column 1 MTPF Act Provision	Column 2 Summary of Provision	Column 3 Delegates	Column 4 Conditions or Limitations
Section 189	The project authority must cause notice of a decision under section 186 to be published in the Government Gazette and in a newspaper being circulated throughout the area affected by the decision.	<ul style="list-style-type: none"> • Director General, MTIA • Chief Executive Officer, MRPV • Director, Commercial & Legal, MRPV <p>and the following class of positions:</p> <ul style="list-style-type: none"> • Director, Delivery, MRPV • Program Director, MRPV • Project Director, MRPV 	
Section 190	The project authority may temporarily close a road to traffic for the purposes of an approved project if considered necessary to do so for works on the road or neighbouring land to be carried out.	<ul style="list-style-type: none"> • Director General, MTIA • Chief Executive Officer, MRPV • Director, Commercial & Legal, MRPV <p>and the following class of positions:</p> <ul style="list-style-type: none"> • Director, Delivery, MRPV • Program Director, MRPV • Project Director, MRPV 	
Section 196	The project authority may establish or cause to be established as a 'restricted access area' a the project area or land temporarily occupied under section 75 of the Land Acquisition Compensation Act 1986 by use of fencing, barriers, other temporary or permanent means of physical demarcation or signage on or in proximity to the area.	<ul style="list-style-type: none"> • Director General, MTIA • Chief Executive Officer, MRPV • Director, Commercial & Legal, MRPV <p>and the following class of positions:</p> <ul style="list-style-type: none"> • Director, Delivery, MRPV • Program Director, MRPV • Project Director, MRPV 	

MTPF Act	Column 2 Summary of Provision	Column 3 Delegates	Column 4 Conditions or Limitations
<p>Column 1 MTPF Act Provision</p> <p>Section 198</p>	<p>The project authority must issue identity cards to authorised officers appointed for the purposes of exercising functions in respect of restricted access areas.</p>	<ul style="list-style-type: none"> • Director General, MTIA • Chief Executive Officer, MRPV • Director, Commercial & Legal, MRPV <p>and the following class of positions:</p> <ul style="list-style-type: none"> • Director, Delivery, MRPV • Program Director, MRPV • Project Director, MRPV 	
<p>Section 199</p>	<p>The project authority may, by issuing a certificate or making a declaration, authorise a person or class of person to enter and remain in a restricted access area for the purposes of preparing or conducting activities for the purposes of an approved project or carrying out ancillary activities.</p>	<ul style="list-style-type: none"> • Director General, MTIA • Chief Executive Officer, MRPV • Director, Commercial & Legal, MRPV <p>and the following class of positions:</p> <ul style="list-style-type: none"> • Director, Delivery, MRPV • Program Director, MRPV • Project Director, MRPV 	
<p>Sections 200, 201</p>	<p>The project authority may warn any person (other than owner of land or a person authorised in writing by the owner or under the MTPF Act) to leave any part of the restricted access area under the applicable Division of the MTPF Act.</p>	<ul style="list-style-type: none"> • Director General, MTIA • Chief Executive Officer, MRPV • Director, Commercial & Legal, MRPV <p>and the following class of positions:</p> <ul style="list-style-type: none"> • Director, Delivery, MRPV • Program Director, MRPV • Project Director, MRPV 	

MTPF Act	Column 2 Summary of Provision	Column 3 Delegates	Column 4 Conditions or Limitations
<p>Column 1 MTPF Act Provision</p> <p>Sections 211, 211A</p>	<p>The project authority:</p> <ul style="list-style-type: none"> • section 211: must take all reasonable steps to identify all utility infrastructure, and every utility that owns such infrastructure, that may be affected by the development of the declared project; and • section 211A: may give a notice to a utility identified under section 211 of the MTPF Act requiring it state whether it owns, operates or controls the relevant utility infrastructure in the specified area, describe the nature of that infrastructure and its location, and provide plans showing the location of that infrastructure. 	<ul style="list-style-type: none"> • Director General, MTIA • Chief Executive Officer, MRPV • Director, Commercial & Legal, MRPV <p>and the following class of positions:</p> <ul style="list-style-type: none"> • Director, Delivery, MRPV • Program Director, MRPV • Project Director, MRPV 	
<p>Section 213</p>	<p>Following the applicable notice period, the project authority may give written notice to a utility of an intention to commence negotiations with the utility for the purpose of entering a utility agreement.</p>	<ul style="list-style-type: none"> • Director General, MTIA • Chief Executive Officer, MRPV • Director, Commercial & Legal, MRPV <p>and the following class of positions:</p> <ul style="list-style-type: none"> • Director, Delivery, MRPV • Program Director, MRPV • Project Director, MRPV 	
<p>Section 214</p>	<p>The project authority (and the relevant utility) must use all reasonable endeavours to negotiate a utility agreement within 50 business days after notice is given under section 213 of the MTPF Act.</p>	<ul style="list-style-type: none"> • Director General, MTIA • Chief Executive Officer, MRPV • Director, Commercial & Legal, MRPV <p>and the following class of positions:</p> <ul style="list-style-type: none"> • Director, Delivery, MRPV • Program Director, MRPV • Project Director, MRPV 	

MTPF Act	Column 2 Summary of Provision	Column 3 Delegates	Column 4 Conditions or Limitations
<p>Column 1 MTPF Act Provision</p> <p>Section 215</p>	<p>The project authority must give written notice to the Project Minister and Utility Minister for the utility if a utility agreement is not entered into between the parties within the applicable 50 business day period.</p>	<ul style="list-style-type: none"> • Director General, MTIA • Chief Executive Officer, MRPV • Director, Commercial & Legal, MRPV <p>and the following class of positions:</p> <ul style="list-style-type: none"> • Director, Delivery, MRPV • Program Director, MRPV • Project Director, MRPV 	
<p>Sections 216, 217, 218, 224, 225, 227</p>	<p>The project authority may exercise the following project functions for dispute resolution and termination in relation to a utility agreement:</p> <ul style="list-style-type: none"> • section 216: give notice to the other party that a dispute exists; • section 217: use reasonable endeavours to agree on an expert for resolving the dispute; • section 218: inform the Project Minister if the parties have agreed on an expert to be appointed, or otherwise if there has been no such agreement; • section 224: provide a draft utility agreement that identifies the applicable matters in relation to which the parties do not agree; • section 225: make a submission to the expert in relation to the dispute; and • section 227: agree to termination or revocation of a utility agreement approved in accordance with section 226(4) of the MTPF Act. 	<ul style="list-style-type: none"> • Director General, MTIA • Chief Executive Officer, MRPV • Director, Commercial & Legal, MRPV <p>and the following class of positions:</p> <ul style="list-style-type: none"> • Director, Delivery, MRPV • Program Director, MRPV • Project Director, MRPV 	

MTPF Act			
Column 1 MTPF Act Provision	Column 2 Summary of Provision	Column 3 Delegates	Column 4 Conditions or Limitations
<p>Sections 232, 233, 234</p>	<p>The project authority may exercise the following project functions in relation to unnotified utility infrastructure:</p> <ul style="list-style-type: none"> • section 232: give written notice to utilities of the project authority's intention to remove, relocate or protect the infrastructure (as the case may be), and require the utility to agree to the relevant works or carry out the works itself; • section 233: if the project authority does not receive a response or the utility does not agree to the relevant works specified in a notice provided under section 232 of the MTPF Act, remove, relocate or carry out works in relation to utility infrastructure, and give the utility an estimate of costs for which the utility is liable for; and • section 234: notify the relevant utility of any damage caused to unnotified utility infrastructure, and undertake the applicable protection, relocation or removal activities in respect of utility infrastructure (including, if an emergency situation occurs, taking all reasonable steps to end the emergency). 	<ul style="list-style-type: none"> • Director General, MTIA • Chief Executive Officer, MRPV • Director, Commercial & Legal, MRPV <p>and the following class of positions:</p> <ul style="list-style-type: none"> • Director, Delivery, MRPV • Program Director, MRPV • Project Director, MRPV 	

LACA			
Column 1 LACA Provision	Column 2 Summary of Provision	Column 3 Delegates	Column 4 Conditions or Limitations
Section 74 (as modified by section 118(5) of the MTPF Act)	<p>The project authority may, or may authorise another person to:</p> <ul style="list-style-type: none"> enter and remain upon any land (with assistants, vehicles, machinery or equipment); affix or establish any trigonometric stations, survey pegs, marks or poles; undertake flora and fauna surveys, and archaeological investigations; and dig or bore land, and take samples of soil, rock, ground water or minerals. 	<ul style="list-style-type: none"> Director General, MTIA Chief Executive Officer, MRPV Director, Commercial & Legal, MRPV Director, Transport Property, DOT <p>and the following class of positions:</p> <ul style="list-style-type: none"> Director, Delivery, MRPV 	<p>To be exercised by the Director, Transport Property, DOT, unless this is not practicable.</p>
Section 75 (as modified by section 119 of the MTPF Act)	<p>The project authority may, or may authorise another person to enter upon and occupy any land for the purposes:</p> <ul style="list-style-type: none"> digging and taking from the land any clay, stone, gravel, earth or other substance; depositing any material on the land; making cuttings or excavations; taking timber from the land; making and using roads on the land; manufacturing on the land any materials required; demolishing structures (other than places of residence or business); carrying out works on drainage channels, streams or other waterways, or works relating to the diversion of drainage channels, streams or other waterways; or erecting temporary workshops, sheds and buildings. 	<ul style="list-style-type: none"> Director General, MTIA Chief Executive Officer, MRPV Director, Commercial & Legal, MRPV Director, Transport Property, DOT <p>and the following class of positions:</p> <ul style="list-style-type: none"> Director, Delivery, MRPV 	<p>To be exercised by the Director, Transport Property, DOT, unless this is not practicable.</p>

**Major Transport Projects Facilitation Act 2009, Transport Integration Act 2010 and
Land Acquisition and Compensation Act 1986**

INSTRUMENT OF DELEGATION BY SECRETARY

BRIDGE INN ROAD UPGRADE

I, Paul Younis, Secretary to the Department of Transport (**Secretary**) as project authority of the Bridge Inn Road Upgrade project (**Project**), a declared project for which designation of the project area in accordance with Part 4 of the **Major Transport Projects Facilitation Act 2009** (Vic.) (**MTPF Act**) occurred on 27 March 2020, and as project authority being also:

- taken to be specified as a determining referral authority in the Whittlesea Planning Scheme under the **Planning and Environment Act 1987** (Vic.) (**Planning and Environment Act 1987**) by operation of section 102A of the MTPF Act (**determining referral authority**); and
- the Authority for the purpose of the **Land Acquisition and Compensation Act 1986** (Vic.) (**LACA**) as applied by section 113 of the MTPF Act (**Authority**) –

in exercise of the powers vested in me under section 104 of the MTPF Act, section 39 of the **Transport Integration Act 2010** and any and all other enabling powers, hereby delegate to the person(s) from time to time employed within the Department of Transport (**DOT**) (which includes the Major Transport Infrastructure Authority, the administrative office existing in relation to DOT that is responsible for delivery of the Project (**MTIA**) and occupying the positions specified in Column 3 of the Schedule to this instrument (each a **Delegate**) such of:

- the project functions and powers conferred on me under the MTPF Act in respect of the Project;
- my powers, duties and functions as determining referral authority in relation to land in the project area; and
- my powers and functions as the Authority –

as are specified for the Delegate in Column 1 and summarised in Column 2 of the Schedule to this instrument, subject to the following conditions and limitations:

7. any condition or limitation that is specified in Column 4 of the Schedule to this instrument with respect to a power, duty or function that is specified in Column 1 of the Schedule to this instrument; and
8. the condition that the power, duty or function may only be exercised for the purpose of the Project.

If the Delegate considers that a project function is one that, in the particular circumstances, requires referral to the Secretary, then before exercising the project function the Delegate should inform and consult with the Secretary.

In the interpretation of this instrument, the summary of a provision set out in Column 2 of the Schedule to this instrument is for convenience only and, unless a contrary intention appears, does not amend, substitute or delete any part of a provision of the MTPF Act or LACA set out in Column 1 of the Schedule to this instrument or otherwise affect the scope or effect of the power, duty or function delegated.

A Delegate is not authorised to delegate or sub-delegate any power delegated under this instrument.

This delegation will remain valid until it is revoked.

The delegation I signed on 23 April 2020 delegating to persons employed within DOT certain powers, duties and functions in respect of the Project, is hereby revoked.

Dated 2 September 2020

PAUL YOUNIS
Secretary to the Department of Transport

SCHEDULE

MTPF Act			
Column 1 MTPF Act Provision	Column 2 Summary of Provision	Column 3 Delegates	Column 4 Conditions or Limitations
Section 96	The project authority may request the Planning Minister to vary the project area for the approved project.	<ul style="list-style-type: none"> • Director General, MTIA • Chief Executive Officer, Major Road Projects Victoria (MRPV) • Director, Commercial & Legal, MRPV 	
Section 101	<p>The project authority may exercise the project authority's functions, summarised as follows:</p> <ul style="list-style-type: none"> • section 101(a): facilitating development of the approved project; • sections 101(b), (c): evaluating submissions from and negotiating with interested parties; • sections 101(d), (e), (f): making recommendations in relation to, and entering and administering contractual arrangements for, development or delivery of the approved project; • sections 101(g), (h), (i): facilitating and coordinating consultations, and negotiating and entering into arrangements, and coordinating, with statutory authorities, agencies of the State and other bodies or persons involved in, or affected by, development or operation of the approved project; • section 101(i): making recommendations to the Project Minister in relation to facilitating the approved project; • section 101(j): ensuring that agreements and arrangements between the State and any other person for, or relating to, the development or delivery of the e approved project are performed in accordance with their terms; • section 101(k): commissioning transport infrastructure that is developed as part of the approved project; • section 101(l): undertaking any other functions conferred on the project authority under the MTPF Act or any other Act. 	<ul style="list-style-type: none"> • Director General, MTIA • Chief Executive Officer, MRPV • Director, Commercial & Legal, MRPV <p>and the following class of positions:</p> <ul style="list-style-type: none"> • Director, Delivery, MRPV 	

MTPF Act			
Column 1 MTPF Act Provision	Column 2 Summary of Provision	Column 3 Delegates	Column 4 Conditions or Limitations
Section 102	<p>For the purpose of performing its functions, and in addition to all other powers conferred on it by or under any other Act or law, exercising:</p> <ul style="list-style-type: none"> • section 102(1): a specified project power or power conferred on it by or under the MTPF Act; and • Section 102(2): do all other things necessary or convenient to be done for, or in connection with, or as incidental to, the performance of project functions under the MTPF Act. 	<ul style="list-style-type: none"> • Director General, MTIA • Chief Executive Officer, MRPV • Director, Commercial & Legal, MRPV • Director, Transport Property, DOT <p>and the following class of positions:</p> <ul style="list-style-type: none"> • Director, Delivery, MRPV 	
Section 102A	<p>The project authority for an approved project is taken to be specified as a determining referral authority in any planning scheme under the Planning and Environment Act.</p>	<ul style="list-style-type: none"> • Director General, MTIA • Chief Executive Officer, MRPV • Director, Commercial and Legal, MRPV <p>and the following class of positions:</p> <ul style="list-style-type: none"> • Director, Delivery, MRPV • Program Director, MRPV • Project Director, MRPV 	
Section 110	<p>On completion of an approved project, the project authority must notify the Project Minister of the project's completion.</p>	<ul style="list-style-type: none"> • Director General, MTIA • Chief Executive Officer, MRPV 	
Section 112	<p>The project authority may acquire an interest in land in the project area by agreement or by a compulsory process for the purposes of an approved project or any purpose connected with the approved project.</p>	<ul style="list-style-type: none"> • Director, Transport Property, DOT • Director General, MTIA • Chief Executive Officer, MRPV <p>and the following class of positions:</p> <ul style="list-style-type: none"> • Director, Delivery, MRPV 	<p>To be exercised by the Director, Transport Property, DOT, unless this is not practicable.</p> <p>Before acquiring an interest in any land, the delegate must give the Secretary particulars of the land and obtain the Secretary's approval in writing for the acquisition of that land.</p>

MTPF Act			
Column 1 MTPF Act Provision	Column 2 Summary of Provision	Column 3 Delegates	Column 4 Conditions or Limitations
Section 120(4), 120(5)	<p>The project authority must:</p> <ul style="list-style-type: none"> • section 120(4): make an offer for the payment of rent to the owner of the land for the authority's occupation of that land; and • section 120(5): if an amount of rent to be paid is not agreed upon, notify the Valuer-General in writing of any disagreement with an owner of land as to the amount of rent to be paid. 	<ul style="list-style-type: none"> • Director General, MTIA • Chief Executive Officer, MRPV • Director, Transport Property, DOT <p>and the following class of positions:</p> <ul style="list-style-type: none"> • Director, Delivery, MRPV 	
Section 121	<p>The project authority must:</p> <ul style="list-style-type: none"> • give the owner of land a condition report; • negotiate the contents of the condition report should the owner disagree; and • failing which, notify the Valuer General of a dispute under this section. 	<ul style="list-style-type: none"> • Director General, MTIA • Chief Executive Officer, MRPV • Director, Transport Property, DOT <p>and the following class of positions:</p> <ul style="list-style-type: none"> • Director, Delivery, MRPV • Program Director, MRPV • Project Director, MRPV 	
Section 123	<p>A project authority may transfer a building or structure in full or in part settlement of any compensation that the project authority is liable to pay.</p>	<ul style="list-style-type: none"> • Director General, MTIA • Chief Executive Officer, MRPV • Director, Transport Property, DOT 	
Section 124	<p>If a project authority acquires compulsorily under Division 1 of Part 6 to the MTPF Act part of a parcel of land owned by a person, the project authority may require that person to take as compensation land that adjoins the part of the parcel that was not acquired; and that is owned by the project authority or is surplus land.</p>	<ul style="list-style-type: none"> • Director General, MTIA • Chief Executive Officer, MRPV • Director, Transport Property, DOT 	

MTPF Act	Column 1 MTPF Act Provision	Column 2 Summary of Provision	Column 3 Delegates	Column 4 Conditions or Limitations
Sections 127, 129		<p>The project authority is authorised to:</p> <ul style="list-style-type: none"> • section 127: compulsorily acquire a native title right or interest in land in the project area for the purposes of an approved project or any purpose connected with an approved project; • section 129: comply with relevant procedures under the Native Title Act 1993 (Vic.) for acquisition of native title rights and interests. 	<ul style="list-style-type: none"> • Director General, MTIA • Chief Executive Officer, MRPV • Director, Transport Property, DOT 	<p>To be exercised by the Director, Transport Property, DOT, unless this is not practicable.</p> <p>Before acquiring a native title right or interest in land in the project area, the delegate must give the Secretary particulars of the land and obtain the Secretary's approval in writing for the acquisition of that right or interest.</p>
Section 133		<p>The project authority may purchase land outside the project area for the purposes of an approved project, or preservation, restoration or provision of native habitat.</p>	<ul style="list-style-type: none"> • Director General, MTIA • Chief Executive Officer, MRPV • Director, Transport Property, DOT <p>and the following class of positions:</p> <ul style="list-style-type: none"> • Director, Delivery, MRPV 	<p>To be exercised by the Director, Transport Property, DOT, unless this is not practicable.</p> <p>Before purchasing any land outside the project area, the delegate must give the Secretary particulars of the land and obtain the Secretary's approval in writing for the purchase of that land.</p>
Section 137B		<p>The project authority may request the consent of the Project Minister to the surrender to the Crown of land held in fee simple if the land is intended to form part of a lease of land under section 177 of the MTPF Act.</p>	<ul style="list-style-type: none"> • Director General, MTIA • Chief Executive Officer, MRPV • Director, Transport Property, DOT 	
Section 143		<p>The project authority must notify the Minister administering the Crown Land (Reserves) Act 1978 (Vic.) of reservation of land under Subdivision 1, 2 or 2A or Division 6 of the MTPF Act.</p>	<ul style="list-style-type: none"> • Director General, MTIA • Chief Executive Officer, MRPV • Director, Transport Property, DOT 	

MTPF Act			
Column 1 MTPF Act Provision	Column 2 Summary of Provision	Column 3 Delegates	Column 4 Conditions or Limitations
Section 147	The project authority may transfer a building or structure from project land or project authority-owned land or Council-owned land, to other land owned by the Council as compensation.	<ul style="list-style-type: none"> • Director General, MTIA • Chief Executive Officer, MRPV • Director, Transport Property, DOT 	
Section 148	The project authority may require that adjoining land is provided as compensation to Council for land acquired compulsorily.	<ul style="list-style-type: none"> • Director General, MTIA • Chief Executive Officer, MRPV • Director, Transport Property, DOT 	
Section 151	The project authority may enter into possession of project land.	<ul style="list-style-type: none"> • Director General, MTIA • Chief Executive Officer, MRPV • Director, Transport Property, DOT <p>and the following class of positions:</p> <ul style="list-style-type: none"> • Director, Delivery, MRPV 	
Section 152	The project authority must diligently endeavour to obtain agreement with the occupier of project land on terms for entry into possession of the land.	<ul style="list-style-type: none"> • Director General, MTIA • Chief Executive Officer, MRPV • Director, Transport Property, DOT <p>and the following class of positions:</p> <ul style="list-style-type: none"> • Director, Delivery, MRPV • Program Director, MRPV • Project Director, MRPV 	
Section 155(1)	The project authority may enter an agreement in relation to the time of entry into possession of project land, with the consent of the Project Minister.	<ul style="list-style-type: none"> • Coordinator General, MTIA • Chief Executive Officer, MRPV • Director, Transport Property, DOT <p>and the following class of positions:</p> <ul style="list-style-type: none"> • Director, Delivery, MRPV • Program Director, MRPV • Project Director, MRPV 	

MTPF Act			
Column 1 MTPF Act Provision	Column 2 Summary of Provision	Column 3 Delegates	Column 4 Conditions or Limitations
Section 155(3)	The project authority must serve a copy of the certificate provided under section 155(1)(a) of the MTPF Act on the occupier.	<ul style="list-style-type: none"> • Director General, MTIA • Chief Executive Officer, MRPV • Director, Transport Property, DOT <p>and the following class of positions:</p> <ul style="list-style-type: none"> • Director, Delivery, MRPV • Program Director, MRPV • Project Director, MRPV 	
Section 156	The occupation period for project land may be extended by agreement between the project authority and the occupier of the project land.	<ul style="list-style-type: none"> • Director General, MTIA • Chief Executive Officer, MRPV • Director, Transport Property, DOT <p>and the following class of positions:</p> <ul style="list-style-type: none"> • Director, Delivery, MRPV • Program Director, MRPV • Project Director, MRPV 	
Section 158	Rent payable under the applicable Subdivision of the MTPF Act may be recovered as a debt due to the project authority in any court of competent jurisdiction.	<ul style="list-style-type: none"> • Director General, MTIA • Chief Executive Officer, MRPV • Director, Transport Property, DOT • Director, Commercial & Legal, MRPV 	
Section 159	The project authority may issue a warrant to the sheriff where entitled under the applicable Division to enter into possession of project land and an occupier of project land refuses to give up possession of the land or hinders entry to that land.	<ul style="list-style-type: none"> • Director General, MTIA • Chief Executive Officer, MRPV • Director, Commercial & Legal, MRPV 	

MTPF Act			
Column 1 MTPF Act Provision	Column 2 Summary of Provision	Column 3 Delegates	Column 4 Conditions or Limitations
Section 167	<p>The project authority:</p> <ul style="list-style-type: none"> • section 167(1): may carry out or authorise works on public land inside or outside the project area for the purposes of the approved project; and • section 167(2): must notify any Minister, public authority or Council that owns or manages the public land prior to works being carried out or performed. 	<ul style="list-style-type: none"> • Director General, MTIA • Chief Executive Officer, MRPV • Director, Commercial & Legal, MRPV <p>and the following class of positions:</p> <ul style="list-style-type: none"> • Director, Delivery, MRPV • Program Director, MRPV • Project Director, MRPV 	
Section 168A	<p>The project authority may carry out or authorise associated works where an applicable approval has been granted for those works or is not required.</p>	<ul style="list-style-type: none"> • Director General, MTIA • Chief Executive Officer, MRPV • Director, Commercial & Legal, MRPV <p>and the following class of positions:</p> <ul style="list-style-type: none"> • Director, Delivery, MRPV • Program Director, MRPV • Project Director, MRPV 	
Section 170	<p>The project authority may use or authorise use of any Crown land for the purposes of an approved project.</p>	<ul style="list-style-type: none"> • Director General, MTIA • Chief Executive Officer, MRPV • Director, Commercial & Legal, MRPV <p>and the following class of positions:</p> <ul style="list-style-type: none"> • Director, Delivery, MRPV • Program Director, MRPV • Project Director, MRPV 	

MTPF Act			
Column 1 MTPF Act Provision	Column 2 Summary of Provision	Column 3 Delegates	Column 4 Conditions or Limitations
Section 171	The project authority may carry out or authorise works on any land within an easement acquired under the applicable Part of the MTPF Act.	<ul style="list-style-type: none"> • Director General, MTIA • Chief Executive Officer, MRPV • Director, Commercial & Legal, MRPV <p>and the following class of positions:</p> <ul style="list-style-type: none"> • Director, Delivery, MRPV • Program Director, MRPV • Project Director, MRPV 	
Section 171A	The project authority may transfer to a utility any easement acquired over project land for the purposes of relocating utility infrastructure as a result of an approved project.	<ul style="list-style-type: none"> • Director General, MTIA • Chief Executive Officer, MRPV • Director, Transport Property, DOT • Director, Commercial & Legal, MRPV <p>and the following class of positions:</p> <ul style="list-style-type: none"> • Director, Delivery, MRPV • Program Director, MRPV • Project Director, MRPV 	
Section 173	The project authority may issue a licence to any person to enter and use all or any part of project land that is Crown land, or land that the project authority holds in fee simple, for the purposes of the approved project.	<ul style="list-style-type: none"> • Director General, MTIA • Chief Executive Officer, MRPV • Director, Transport Property, DOT <p>and the following class of positions:</p> <ul style="list-style-type: none"> • Director, Delivery, MRPV • Program Director, MRPV • Project Director, MRPV 	
Section 184	The project authority may enter into an agreement concerning the use or development of surplus land upon or in anticipation of disposing of the whole of its interest in the land.	<ul style="list-style-type: none"> • Director General, MTIA • Chief Executive Officer, MRPV • Director, Transport Property, DOT 	

MTPF Act			
Column 1 MTPF Act Provision	Column 2 Summary of Provision	Column 3 Delegates	Column 4 Conditions or Limitations
Section 185	The project authority may sell, lease or licence any surplus land held in fee simple.	<ul style="list-style-type: none"> • Director General, MTIA • Chief Executive Officer, MRPV • Director, Transport Property, DOT 	
Section 186	<p>The project authority may:</p> <ul style="list-style-type: none"> • open, discontinue, construct, relocate or realign roads, and close any road to traffic; • carry out improvements to roads in the project area; • construct roads over or under roads constructed or to be constructed in the project area; • construct any road in the project area over or under any other roads; and • cause fences, posts, or other structures to be erected along any road constructed or to be constructed in the project area, or across any entrance, approach or means of access to, any road constructed or to be constructed in the project area. 	<ul style="list-style-type: none"> • Director General, MTIA • Chief Executive Officer, MRPV • Director, Commercial & Legal, MRPV <p>and the following class of positions:</p> <ul style="list-style-type: none"> • Director, Delivery, MRPV • Program Director, MRPV • Project Director, MRPV 	
Section 187	The project authority must advise the coordinating road authority before exercising any power under section 186.	<ul style="list-style-type: none"> • Director General, MTIA • Chief Executive Officer, MRPV • Director, Commercial & Legal, MRPV <p>and the following class of positions:</p> <ul style="list-style-type: none"> • Director, Delivery, MRPV • Program Director, MRPV • Project Director, MRPV 	

MTPF Act			
Column 1 MTPF Act Provision	Column 2 Summary of Provision	Column 3 Delegates	Column 4 Conditions or Limitations
Section 189	The project authority must cause notice of a decision under section 186 to be published in the Government Gazette and in a newspaper being circulated throughout the area affected by the decision.	<ul style="list-style-type: none"> • Director General, MTIA • Chief Executive Officer, MRPV • Director, Commercial & Legal, MRPV <p>and the following class of positions:</p> <ul style="list-style-type: none"> • Director, Delivery, MRPV • Program Director, MRPV • Project Director, MRPV 	
Section 190	The project authority may temporarily close a road to traffic for the purposes of an approved project if considered necessary to do so for works on the road or neighbouring land to be carried out.	<ul style="list-style-type: none"> • Director General, MTIA • Chief Executive Officer, MRPV • Director, Commercial & Legal, MRPV <p>and the following class of positions:</p> <ul style="list-style-type: none"> • Director, Delivery, MRPV • Program Director, MRPV • Project Director, MRPV 	
Section 196	The project authority may establish or cause to be established as a 'restricted access area' a the project area or land temporarily occupied under section 75 of the Land Acquisition Compensation Act 1986 by use of fencing, barriers, other temporary or permanent means of physical demarcation or signage on or in proximity to the area.	<ul style="list-style-type: none"> • Director General, MTIA • Chief Executive Officer, MRPV • Director, Commercial & Legal, MRPV <p>and the following class of positions:</p> <ul style="list-style-type: none"> • Director, Delivery, MRPV • Program Director, MRPV • Project Director, MRPV 	

MTPF Act			
Column 1 MTPF Act Provision	Column 2 Summary of Provision	Column 3 Delegates	Column 4 Conditions or Limitations
Section 198	The project authority must issue identity cards to authorised officers appointed for the purposes of exercising functions in respect of restricted access areas.	<ul style="list-style-type: none"> • Director General, MTIA • Chief Executive Officer, MRPV • Director, Commercial & Legal, MRPV <p>and the following class of positions:</p> <ul style="list-style-type: none"> • Director, Delivery, MRPV • Program Director, MRPV • Project Director, MRPV 	
Section 199	The project authority may, by issuing a certificate or making a declaration, authorise a person or class of person to enter and remain in a restricted access area for the purposes of preparing or conducting activities for the purposes of an approved project or carrying out ancillary activities.	<ul style="list-style-type: none"> • Director General, MTIA • Chief Executive Officer, MRPV • Director, Commercial & Legal, MRPV <p>and the following class of positions:</p> <ul style="list-style-type: none"> • Director, Delivery, MRPV • Program Director, MRPV • Project Director, MRPV 	
Sections 200, 201	The project authority may warn any person (other than owner of land or a person authorised in writing by the owner or under the MTPF Act) to leave any part of the restricted access area under the applicable Division of the MTPF Act.	<ul style="list-style-type: none"> • Director General, MTIA • Chief Executive Officer, MRPV • Director, Commercial & Legal, MRPV <p>and the following class of positions:</p> <ul style="list-style-type: none"> • Director, Delivery, MRPV • Program Director, MRPV • Project Director, MRPV 	

MTPF Act			
Column 1 MTPF Act Provision	Column 2 Summary of Provision	Column 3 Delegates	Column 4 Conditions or Limitations
Sections 211, 211A	<p>The project authority:</p> <ul style="list-style-type: none"> • section 211: must take all reasonable steps to identify all utility infrastructure, and every utility that owns such infrastructure, that may be affected by the development of the declared project; and • section 211A: may give a notice to a utility identified under section 211 of the MTPF Act requiring it state whether it owns, operates or controls the relevant utility infrastructure in the specified area, describe the nature of that infrastructure and its location, and provide plans showing the location of that infrastructure. 	<ul style="list-style-type: none"> • Director General, MTIA • Chief Executive Officer, MRPV • Director, Commercial & Legal, MRPV <p>and the following class of positions:</p> <ul style="list-style-type: none"> • Director, Delivery, MRPV • Program Director, MRPV • Project Director, MRPV 	
Section 213	<p>Following the applicable notice period, the project authority may give written notice to a utility of an intention to commence negotiations with the utility for the purpose of entering a utility agreement.</p>	<ul style="list-style-type: none"> • Director General, MTIA • Chief Executive Officer, MRPV • Director, Commercial & Legal, MRPV <p>and the following class of positions:</p> <ul style="list-style-type: none"> • Director, Delivery, MRPV • Program Director, MRPV • Project Director, MRPV 	
Section 214	<p>The project authority (and the relevant utility) must use all reasonable endeavours to negotiate a utility agreement within 50 business days after notice is given under section 213 of the MTPF Act.</p>	<ul style="list-style-type: none"> • Director General, MTIA • Chief Executive Officer, MRPV • Director, Commercial & Legal, MRPV <p>and the following class of positions:</p> <ul style="list-style-type: none"> • Director, Delivery, MRPV • Program Director, MRPV • Project Director, MRPV 	

MTPF Act			
Column 1 MTPF Act Provision	Column 2 Summary of Provision	Column 3 Delegates	Column 4 Conditions or Limitations
Section 215	The project authority must give written notice to the Project Minister and Utility Minister for the utility if a utility agreement is not entered into between the parties within the applicable 50 business day period.	<ul style="list-style-type: none"> • Director General, MTIA • Chief Executive Officer, MRPV • Director, Commercial & Legal, MRPV <p>and the following class of positions:</p> <ul style="list-style-type: none"> • Director, Delivery, MRPV • Program Director, MRPV • Project Director, MRPV 	
Sections 216, 217, 218, 224, 225, 227	<p>The project authority may exercise the following project functions for dispute resolution and termination in relation to a utility agreement:</p> <ul style="list-style-type: none"> • section 216: give notice to the other party that a dispute exists; • section 217: use reasonable endeavours to agree on an expert for resolving the dispute; • section 218: inform the Project Minister if the parties have agreed on an expert to be appointed, or otherwise if there has been no such agreement; • section 224: provide a draft utility agreement that identifies the applicable matters in relation to which the parties do not agree; • section 225: make a submission to the expert in relation to the dispute; and • section 227: agree to termination or revocation of a utility agreement approved in accordance with section 226(4) of the MTPF Act. 	<ul style="list-style-type: none"> • Director General, MTIA • Chief Executive Officer, MRPV • Director, Commercial & Legal, MRPV <p>and the following class of positions:</p> <ul style="list-style-type: none"> • Director, Delivery, MRPV • Program Director, MRPV • Project Director, MRPV 	

MTPF Act			
Column 1 MTPF Act Provision	Column 2 Summary of Provision	Column 3 Delegates	Column 4 Conditions or Limitations
<p>Sections 232, 233, 234</p>	<p>The project authority may exercise the following project functions in relation to unnotified utility infrastructure:</p> <ul style="list-style-type: none"> • section 232: give written notice to utilities of the project authority's intention to remove, relocate or protect the infrastructure (as the case may be), and require the utility to agree to the relevant works or carry out the works itself; • section 233: if the project authority does not receive a response or the utility does not agree to the relevant works specified in a notice provided under section 232 of the MTPF Act, remove, relocate or carry out works in relation to utility infrastructure, and give the utility an estimate of costs for which the utility is liable for; and • section 234: notify the relevant utility of any damage caused to unnotified utility infrastructure, and undertake the applicable protection, relocation or removal activities in respect of utility infrastructure (including, if an emergency situation occurs, taking all reasonable steps to end the emergency). 	<ul style="list-style-type: none"> • Director General, MTIA • Chief Executive Officer, MRPV • Director, Commercial & Legal, MRPV <p>and the following class of positions:</p> <ul style="list-style-type: none"> • Director, Delivery, MRPV • Program Director, MRPV • Project Director, MRPV 	

LACA	Column 1 LACA Provision	Column 2 Summary of Provision	Column 3 Delegates	Column 4 Conditions or Limitations
Section 74 (as modified by section 118(5) of the MTPF Act)	<p>The project authority may, or may authorise another person to:</p> <ul style="list-style-type: none"> • enter and remain upon any land (with assistants, vehicles, machinery or equipment); • affix or establish any trigonometric stations, survey pegs, marks or poles; • undertake flora and fauna surveys, and archaeological investigations; and • dig or bore land, and take samples of soil, rock, ground water or minerals. 	<ul style="list-style-type: none"> • Director General, MTIA • Chief Executive Officer, MRPV • Director, Commercial & Legal, MRPV • Director, Transport Property, DOT <p>and the following class of positions:</p> <ul style="list-style-type: none"> • Director, Delivery, MRPV 	<p>To be exercised by the Director, Transport Property, DOT, unless this is not practicable.</p>	
Section 75 (as modified by section 119 of the MTPF Act)	<p>The project authority may, or may authorise another person to enter upon and occupy any land for the purposes:</p> <ul style="list-style-type: none"> • digging and taking from the land any clay, stone, gravel, earth or other substance; • depositing any material on the land; • making cuttings or excavations; • taking timber from the land; • making and using roads on the land; • manufacturing on the land any materials required; • demolishing structures (other than places of residence or business); • carrying out works on drainage channels, streams or other waterways, or works relating to the diversion of drainage channels, streams or other waterways; or • erecting temporary workshops, sheds and buildings. 	<ul style="list-style-type: none"> • Director General, MTIA • Chief Executive Officer, MRPV • Director, Commercial & Legal, MRPV • Director, Transport Property, DOT <p>and the following class of positions:</p> <ul style="list-style-type: none"> • Director, Delivery, MRPV 	<p>To be exercised by the Director, Transport Property, DOT, unless this is not practicable.</p>	

**Major Transport Projects Facilitation Act 2009, Transport Integration Act 2010 and
Land Acquisition and Compensation Act 1986**

INSTRUMENT OF DELEGATION BY SECRETARY

CRAIGIEBURN ROAD UPGRADE

I, Paul Younis, Secretary to the Department of Transport (**Secretary**) as project authority of the Craigieburn Road Upgrade project (**Project**), a declared project for which designation of the project area in accordance with Part 4 of the **Major Transport Projects Facilitation Act 2009** (**Vic.**) (**MTPF Act**) occurred on 27 March 2020, and as project authority being also:

- taken to be specified as a determining referral authority in the Hume Planning Scheme under the **Planning and Environment Act 1987** (**Vic.**) (**Planning and Environment Act 1987**) by operation of section 102A of the MTPF Act (**determining referral authority**); and
- the Authority for the purpose of the **Land Acquisition and Compensation Act 1986** (**Vic.**) (**LACA**) as applied by section 113 of the MTPF Act (**Authority**) –

in exercise of the powers vested in me under section 104 of the MTPF Act, section 39 of the **Transport Integration Act 2010** and any and all other enabling powers, hereby delegate to the person(s) from time to time employed within the Department of Transport (**DOT**) (which includes the Major Transport Infrastructure Authority, the administrative office existing in relation to DOT that is responsible for delivery of the Project (**MTIA**) and occupying the positions specified in Column 3 of the Schedule to this instrument (each a **Delegate**) such of:

- the project functions and powers conferred on me under the MTPF Act in respect of the Project;
- my powers, duties and functions as determining referral authority in relation to land in the project area; and
- my powers and functions as the Authority –

as are specified for the Delegate in Column 1 and summarised in Column 2 of the Schedule to this instrument, subject to the following conditions and limitations:

9. any condition or limitation that is specified in Column 4 of the Schedule to this instrument with respect to a power, duty or function that is specified in Column 1 of the Schedule to this instrument; and
10. the condition that the power, duty or function may only be exercised for the purpose of the Project.

If the Delegate considers that a project function is one that, in the particular circumstances, requires referral to the Secretary, then before exercising the project function the Delegate should inform and consult with the Secretary.

In the interpretation of this instrument, the summary of a provision set out in Column 2 of the Schedule to this instrument is for convenience only and, unless a contrary intention appears, does not amend, substitute or delete any part of a provision of the MTPF Act or LACA set out in Column 1 of the Schedule to this instrument or otherwise affect the scope or effect of the power, duty or function delegated.

A Delegate is not authorised to delegate or sub-delegate any power delegated under this instrument.

This delegation will remain valid until it is revoked.

The delegation I signed on 23 April 2020 delegating to persons employed within DOT certain powers, duties and functions in respect of the Project, is hereby revoked.

Dated 2 September 2020

PAUL YOUNIS
Secretary to the Department of Transport

SCHEDULE

MTPF Act			
Column 1 MTPF Act Provision	Column 2 Summary of Provision	Column 3 Delegates	Column 4 Conditions or Limitations
Section 96	The project authority may request the Planning Minister to vary the project area for the approved project.	<ul style="list-style-type: none"> • Director General, MTIA • Chief Executive Officer, Major Road Projects Victoria (MRPV) • Director, Commercial & Legal, MRPV 	
Section 101	<p>The project authority may exercise the project authority's functions, summarised as follows:</p> <ul style="list-style-type: none"> • section 101(a): facilitating development of the approved project; • sections 101(b), (c): evaluating submissions from and negotiating with interested parties; • sections 101(d), (e), (f): making recommendations in relation to, and entering and administering contractual arrangements for, development or delivery of the approved project; • sections 101(g), (h), (i): facilitating and coordinating consultations, and negotiating and entering into arrangements, and coordinating, with statutory authorities, agencies of the State and other bodies or persons involved in, or affected by, development or operation of the approved project; • section 101(i): making recommendations to the Project Minister in relation to facilitating the approved project; • section 101(j): ensuring that agreements and arrangements between the State and any other person for, or relating to, the development or delivery of the e approved project are performed in accordance with their terms; • section 101(k): commissioning transport infrastructure that is developed as part of the approved project; • section 101(l): undertaking any other functions conferred on the project authority under the MTPF Act or any other Act. 	<ul style="list-style-type: none"> • Director General, MTIA • Chief Executive Officer, MRPV • Director, Commercial & Legal, MRPV <p>and the following class of positions:</p> <ul style="list-style-type: none"> • Director, Delivery, MRPV 	

MTPF Act			
Column 1 MTPF Act Provision	Column 2 Summary of Provision	Column 3 Delegates	Column 4 Conditions or Limitations
Section 102	<p>For the purpose of performing its functions, and in addition to all other powers conferred on it by or under any other Act or law, exercising:</p> <ul style="list-style-type: none"> • section 102(1): a specified project power or power conferred on it by or under the MTPF Act; and • Section 102(2): do all other things necessary or convenient to be done for, or in connection with, or as incidental to, the performance of project functions under the MTPF Act. 	<ul style="list-style-type: none"> • Director General, MTIA • Chief Executive Officer, MRPV • Director, Commercial & Legal, MRPV • Director, Transport Property, DOT <p>and the following class of positions:</p> <ul style="list-style-type: none"> • Director, Delivery, MRPV 	
Section 102A	<p>The project authority for an approved project is taken to be specified as a determining referral authority in any planning scheme under the Planning and Environment Act.</p>	<ul style="list-style-type: none"> • Director General, MTIA • Chief Executive Officer, MRPV • Director, Commercial and Legal, MRPV <p>and the following class of positions:</p> <ul style="list-style-type: none"> • Director, Delivery, MRPV • Program Director, MRPV • Project Director, MRPV 	
Section 110	<p>On completion of an approved project, the project authority must notify the Project Minister of the project's completion.</p>	<ul style="list-style-type: none"> • Director General, MTIA • Chief Executive Officer, MRPV 	
Section 112	<p>The project authority may acquire an interest in land in the project area by agreement or by a compulsory process for the purposes of an approved project or any purpose connected with the approved project.</p>	<ul style="list-style-type: none"> • Director, Transport Property, DOT • Director General, MTIA • Chief Executive Officer, MRPV <p>and the following class of positions:</p> <ul style="list-style-type: none"> • Director, Delivery, MRPV 	<p>To be exercised by the Director, Transport Property, DOT, unless this is not practicable.</p> <p>Before acquiring an interest in any land, the delegate must give the Secretary particulars of the land and obtain the Secretary's approval in writing for the acquisition of that land.</p>

MTPF Act			
Column 1 MTPF Act Provision	Column 2 Summary of Provision	Column 3 Delegates	Column 4 Conditions or Limitations
Section 120(4), 120(5)	<p>The project authority must:</p> <ul style="list-style-type: none"> • section 120(4): make an offer for the payment of rent to the owner of the land for the authority's occupation of that land; and • section 120(5): if an amount of rent to be paid is not agreed upon, notify the Valuer-General in writing of any disagreement with an owner of land as to the amount of rent to be paid. 	<ul style="list-style-type: none"> • Director General, MTIA • Chief Executive Officer, MRPV • Director, Transport Property, DOT <p>and the following class of positions:</p> <ul style="list-style-type: none"> • Director, Delivery, MRPV 	
Section 121	<p>The project authority must:</p> <ul style="list-style-type: none"> • give the owner of land a condition report; • negotiate the contents of the condition report should the owner disagree; and • failing which, notify the Valuer General of a dispute under this section. 	<ul style="list-style-type: none"> • Director General, MTIA • Chief Executive Officer, MRPV • Director, Transport Property, DOT <p>and the following class of positions:</p> <ul style="list-style-type: none"> • Director, Delivery, MRPV • Program Director, MRPV • Project Director, MRPV 	
Section 123	<p>A project authority may transfer a building or structure in full or in part settlement of any compensation that the project authority is liable to pay.</p>	<ul style="list-style-type: none"> • Director General, MTIA • Chief Executive Officer, MRPV • Director, Transport Property, DOT 	
Section 124	<p>If a project authority acquires compulsorily under Division 1 of Part 6 to the MTPF Act part of a parcel of land owned by a person, the project authority may require that person to take as compensation land that adjoins the part of the parcel that was not acquired; and that is owned by the project authority or is surplus land.</p>	<ul style="list-style-type: none"> • Director General, MTIA • Chief Executive Officer, MRPV • Director, Transport Property, DOT 	

MTPF Act			
Column 1 MTPF Act Provision	Column 2 Summary of Provision	Column 3 Delegates	Column 4 Conditions or Limitations
Sections 127, 129	<p>The project authority is authorised to:</p> <ul style="list-style-type: none"> section 127: compulsorily acquire a native title right or interest in land in the project area for the purposes of an approved project or any purpose connected with an approved project; section 129: comply with relevant procedures under the Native Title Act 1993 (Vic.) for acquisition of native title rights and interests. 	<ul style="list-style-type: none"> Director General, MTIA Chief Executive Officer, MRPV Director, Transport Property, DOT 	<p>To be exercised by the Director, Transport Property, DOT, unless this is not practicable.</p> <p>Before acquiring a native title right or interest in land in the project area, the delegate must give the Secretary particulars of the land and obtain the Secretary's approval in writing for the acquisition of that right or interest.</p>
Section 133	<p>The project authority may purchase land outside the project area for the purposes of an approved project, or preservation, restoration or provision of native habitat.</p>	<ul style="list-style-type: none"> Director General, MTIA Chief Executive Officer, MRPV Director, Transport Property, DOT <p>and the following class of positions:</p> <ul style="list-style-type: none"> Director, Delivery, MRPV 	<p>To be exercised by the Director, Transport Property, DOT, unless this is not practicable.</p> <p>Before purchasing any land outside the project area, the delegate must give the Secretary particulars of the land and obtain the Secretary's approval in writing for the purchase of that land.</p>
Section 137B	<p>The project authority may request the consent of the Project Minister to the surrender to the Crown of land held in fee simple if the land is intended to form part of a lease of land under section 177 of the MTPF Act.</p>	<ul style="list-style-type: none"> Director General, MTIA Chief Executive Officer, MRPV Director, Transport Property, DOT 	
Section 143	<p>The project authority must notify the Minister administering the Crown Land (Reserves) Act 1978 (Vic.) of reservation of land under Subdivision 1, 2 or 2A or Division 6 of the MTPF Act.</p>	<ul style="list-style-type: none"> Director General, MTIA Chief Executive Officer, MRPV Director, Transport Property, DOT 	

MTPF Act			
Column 1 MTPF Act Provision	Column 2 Summary of Provision	Column 3 Delegates	Column 4 Conditions or Limitations
Section 147	The project authority may transfer a building or structure from project land or project authority-owned land or Council-owned land, to other land owned by the Council as compensation.	<ul style="list-style-type: none"> • Director General, MTIA • Chief Executive Officer, MRPV • Director, Transport Property, DOT 	
Section 148	The project authority may require that adjoining land is provided as compensation to Council for land acquired compulsorily.	<ul style="list-style-type: none"> • Director General, MTIA • Chief Executive Officer, MRPV • Director, Transport Property, DOT 	
Section 151	The project authority may enter into possession of project land.	<ul style="list-style-type: none"> • Director General, MTIA • Chief Executive Officer, MRPV • Director, Transport Property, DOT <p>and the following class of positions:</p> <ul style="list-style-type: none"> • Director, Delivery, MRPV 	
Section 152	The project authority must diligently endeavour to obtain agreement with the occupier of project land on terms for entry into possession of the land.	<ul style="list-style-type: none"> • Director General, MTIA • Chief Executive Officer, MRPV • Director, Transport Property, DOT <p>and the following class of positions:</p> <ul style="list-style-type: none"> • Director, Delivery, MRPV • Program Director, MRPV • Project Director, MRPV 	
Section 155(1)	The project authority may enter an agreement in relation to the time of entry into possession of project land, with the consent of the Project Minister.	<ul style="list-style-type: none"> • Coordinator General, MTIA • Chief Executive Officer, MRPV • Director, Transport Property, DOT <p>and the following class of positions:</p> <ul style="list-style-type: none"> • Director, Delivery, MRPV • Program Director, MRPV • Project Director, MRPV 	

MTPF Act			
Column 1 MTPF Act Provision	Column 2 Summary of Provision	Column 3 Delegates	Column 4 Conditions or Limitations
Section 155(3)	The project authority must serve a copy of the certificate provided under section 155(1)(a) of the MTPF Act on the occupier.	<ul style="list-style-type: none"> • Director General, MTIA • Chief Executive Officer, MRPV • Director, Transport Property, DOT <p>and the following class of positions:</p> <ul style="list-style-type: none"> • Director, Delivery, MRPV • Program Director, MRPV • Project Director, MRPV 	
Section 156	The occupation period for project land may be extended by agreement between the project authority and the occupier of the project land.	<ul style="list-style-type: none"> • Director General, MTIA • Chief Executive Officer, MRPV • Director, Transport Property, DOT <p>and the following class of positions:</p> <ul style="list-style-type: none"> • Director, Delivery, MRPV • Program Director, MRPV • Project Director, MRPV 	
Section 158	Rent payable under the applicable Subdivision of the MTPF Act may be recovered as a debt due to the project authority in any court of competent jurisdiction.	<ul style="list-style-type: none"> • Director General, MTIA • Chief Executive Officer, MRPV • Director, Transport Property, DOT • Director, Commercial & Legal, MRPV 	
Section 159	The project authority may issue a warrant to the sheriff where entitled under the applicable Division to enter into possession of project land and an occupier of project land refuses to give up possession of the land or hinders entry to that land.	<ul style="list-style-type: none"> • Director General, MTIA • Chief Executive Officer, MRPV • Director, Commercial & Legal, MRPV 	

MTPF Act			
Column 1 MTPF Act Provision	Column 2 Summary of Provision	Column 3 Delegates	Column 4 Conditions or Limitations
Section 167	<p>The project authority:</p> <ul style="list-style-type: none"> • section 167(1): may carry out or authorise works on public land inside or outside the project area for the purposes of the approved project; and • section 167(2): must notify any Minister, public authority or Council that owns or manages the public land prior to works being carried out or performed. 	<ul style="list-style-type: none"> • Director General, MTIA • Chief Executive Officer, MRPV • Director, Commercial & Legal, MRPV <p>and the following class of positions:</p> <ul style="list-style-type: none"> • Director, Delivery, MRPV • Program Director, MRPV • Project Director, MRPV 	
Section 168A	<p>The project authority may carry out or authorise associated works where an applicable approval has been granted for those works or is not required.</p>	<ul style="list-style-type: none"> • Director General, MTIA • Chief Executive Officer, MRPV • Director, Commercial & Legal, MRPV <p>and the following class of positions:</p> <ul style="list-style-type: none"> • Director, Delivery, MRPV • Program Director, MRPV • Project Director, MRPV 	
Section 170	<p>The project authority may use or authorise use of any Crown land for the purposes of an approved project.</p>	<ul style="list-style-type: none"> • Director General, MTIA • Chief Executive Officer, MRPV • Director, Commercial & Legal, MRPV <p>and the following class of positions:</p> <ul style="list-style-type: none"> • Director, Delivery, MRPV • Program Director, MRPV • Project Director, MRPV 	

MTPF Act			
Column 1 MTPF Act Provision	Column 2 Summary of Provision	Column 3 Delegates	Column 4 Conditions or Limitations
Section 171	The project authority may carry out or authorise works on any land within an easement acquired under the applicable Part of the MTPF Act.	<ul style="list-style-type: none"> • Director General, MTIA • Chief Executive Officer, MRPV • Director, Commercial & Legal, MRPV <p>and the following class of positions:</p> <ul style="list-style-type: none"> • Director, Delivery, MRPV • Program Director, MRPV • Project Director, MRPV 	
Section 171A	The project authority may transfer to a utility any easement acquired over project land for the purposes of relocating utility infrastructure as a result of an approved project.	<ul style="list-style-type: none"> • Director General, MTIA • Chief Executive Officer, MRPV • Director, Transport Property, DOT • Director, Commercial & Legal, MRPV <p>and the following class of positions:</p> <ul style="list-style-type: none"> • Director, Delivery, MRPV • Program Director, MRPV • Project Director, MRPV 	
Section 173	The project authority may issue a licence to any person to enter and use all or any part of project land that is Crown land, or land that the project authority holds in fee simple, for the purposes of the approved project.	<ul style="list-style-type: none"> • Director General, MTIA • Chief Executive Officer, MRPV • Director, Transport Property, DOT <p>and the following class of positions:</p> <ul style="list-style-type: none"> • Director, Delivery, MRPV • Program Director, MRPV • Project Director, MRPV 	
Section 184	The project authority may enter into an agreement concerning the use or development of surplus land upon or in anticipation of disposing of the whole of its interest in the land.	<ul style="list-style-type: none"> • Director General, MTIA • Chief Executive Officer, MRPV • Director, Transport Property, DOT 	

MTPF Act			
Column 1 MTPF Act Provision	Column 2 Summary of Provision	Column 3 Delegates	Column 4 Conditions or Limitations
Section 185	The project authority may sell, lease or licence any surplus land held in fee simple.	<ul style="list-style-type: none"> • Director General, MTIA • Chief Executive Officer, MRPV • Director, Transport Property, DOT 	
Section 186	<p>The project authority may:</p> <ul style="list-style-type: none"> • open, discontinue, construct, relocate or realign roads, and close any road to traffic; • carry out improvements to roads in the project area; • construct roads over or under roads constructed or to be constructed in the project area; • construct any road in the project area over or under any other roads; and • cause fences, posts, or other structures to be erected along any road constructed or to be constructed in the project area, or across any entrance, approach or means of access to, any road constructed or to be constructed in the project area. 	<ul style="list-style-type: none"> • Director General, MTIA • Chief Executive Officer, MRPV • Director, Commercial & Legal, MRPV <p>and the following class of positions:</p> <ul style="list-style-type: none"> • Director, Delivery, MRPV • Program Director, MRPV • Project Director, MRPV 	
Section 187	The project authority must advise the coordinating road authority before exercising any power under section 186.	<ul style="list-style-type: none"> • Director General, MTIA • Chief Executive Officer, MRPV • Director, Commercial & Legal, MRPV <p>and the following class of positions:</p> <ul style="list-style-type: none"> • Director, Delivery, MRPV • Program Director, MRPV • Project Director, MRPV 	

MTPF Act			
Column 1 MTPF Act Provision	Column 2 Summary of Provision	Column 3 Delegates	Column 4 Conditions or Limitations
Section 189	The project authority must cause notice of a decision under section 186 to be published in the Government Gazette and in a newspaper being circulated throughout the area affected by the decision.	<ul style="list-style-type: none"> • Director General, MTIA • Chief Executive Officer, MRPV • Director, Commercial & Legal, MRPV <p>and the following class of positions:</p> <ul style="list-style-type: none"> • Director, Delivery, MRPV • Program Director, MRPV • Project Director, MRPV 	
Section 190	The project authority may temporarily close a road to traffic for the purposes of an approved project if considered necessary to do so for works on the road or neighbouring land to be carried out.	<ul style="list-style-type: none"> • Director General, MTIA • Chief Executive Officer, MRPV • Director, Commercial & Legal, MRPV <p>and the following class of positions:</p> <ul style="list-style-type: none"> • Director, Delivery, MRPV • Program Director, MRPV • Project Director, MRPV 	
Section 196	The project authority may establish or cause to be established as a 'restricted access area' a the project area or land temporarily occupied under section 75 of the Land Acquisition Compensation Act 1986 by use of fencing, barriers, other temporary or permanent means of physical demarcation or signage on or in proximity to the area.	<ul style="list-style-type: none"> • Director General, MTIA • Chief Executive Officer, MRPV • Director, Commercial & Legal, MRPV <p>and the following class of positions:</p> <ul style="list-style-type: none"> • Director, Delivery, MRPV • Program Director, MRPV • Project Director, MRPV 	

MTPF Act			
Column 1 MTPF Act Provision	Column 2 Summary of Provision	Column 3 Delegates	Column 4 Conditions or Limitations
Section 198	The project authority must issue identity cards to authorised officers appointed for the purposes of exercising functions in respect of restricted access areas.	<ul style="list-style-type: none"> • Director General, MTIA • Chief Executive Officer, MRPV • Director, Commercial & Legal, MRPV <p>and the following class of positions:</p> <ul style="list-style-type: none"> • Director, Delivery, MRPV • Program Director, MRPV • Project Director, MRPV 	
Section 199	The project authority may, by issuing a certificate or making a declaration, authorise a person or class of person to enter and remain in a restricted access area for the purposes of preparing or conducting activities for the purposes of an approved project or carrying out ancillary activities.	<ul style="list-style-type: none"> • Director General, MTIA • Chief Executive Officer, MRPV • Director, Commercial & Legal, MRPV <p>and the following class of positions:</p> <ul style="list-style-type: none"> • Director, Delivery, MRPV • Program Director, MRPV • Project Director, MRPV 	
Sections 200, 201	The project authority may warn any person (other than owner of land or a person authorised in writing by the owner or under the MTPF Act) to leave any part of the restricted access area under the applicable Division of the MTPF Act.	<ul style="list-style-type: none"> • Director General, MTIA • Chief Executive Officer, MRPV • Director, Commercial & Legal, MRPV <p>and the following class of positions:</p> <ul style="list-style-type: none"> • Director, Delivery, MRPV • Program Director, MRPV • Project Director, MRPV 	

MTPF Act			
Column 1 MTPF Act Provision	Column 2 Summary of Provision	Column 3 Delegates	Column 4 Conditions or Limitations
Sections 211, 211A	<p>The project authority:</p> <ul style="list-style-type: none"> • section 211: must take all reasonable steps to identify all utility infrastructure, and every utility that owns such infrastructure, that may be affected by the development of the declared project; and • section 211A: may give a notice to a utility identified under section 211 of the MTPF Act requiring it state whether it owns, operates or controls the relevant utility infrastructure in the specified area, describe the nature of that infrastructure and its location, and provide plans showing the location of that infrastructure. 	<ul style="list-style-type: none"> • Director General, MTIA • Chief Executive Officer, MRPV • Director, Commercial & Legal, MRPV <p>and the following class of positions:</p> <ul style="list-style-type: none"> • Director, Delivery, MRPV • Program Director, MRPV • Project Director, MRPV 	
Section 213	<p>Following the applicable notice period, the project authority may give written notice to a utility of an intention to commence negotiations with the utility for the purpose of entering a utility agreement.</p>	<ul style="list-style-type: none"> • Director General, MTIA • Chief Executive Officer, MRPV • Director, Commercial & Legal, MRPV <p>and the following class of positions:</p> <ul style="list-style-type: none"> • Director, Delivery, MRPV • Program Director, MRPV • Project Director, MRPV 	
Section 214	<p>The project authority (and the relevant utility) must use all reasonable endeavours to negotiate a utility agreement within 50 business days after notice is given under section 213 of the MTPF Act.</p>	<ul style="list-style-type: none"> • Director General, MTIA • Chief Executive Officer, MRPV • Director, Commercial & Legal, MRPV <p>and the following class of positions:</p> <ul style="list-style-type: none"> • Director, Delivery, MRPV • Program Director, MRPV • Project Director, MRPV 	

MTPF Act			
Column 1 MTPF Act Provision	Column 2 Summary of Provision	Column 3 Delegates	Column 4 Conditions or Limitations
Section 215	The project authority must give written notice to the Project Minister and Utility Minister for the utility if a utility agreement is not entered into between the parties within the applicable 50 business day period.	<ul style="list-style-type: none"> • Director General, MTIA • Chief Executive Officer, MRPV • Director, Commercial & Legal, MRPV <p>and the following class of positions:</p> <ul style="list-style-type: none"> • Director, Delivery, MRPV • Program Director, MRPV • Project Director, MRPV 	
Sections 216, 217, 218, 224, 225, 227	<p>The project authority may exercise the following project functions for dispute resolution and termination in relation to a utility agreement:</p> <ul style="list-style-type: none"> • section 216: give notice to the other party that a dispute exists; • section 217: use reasonable endeavours to agree on an expert for resolving the dispute; • section 218: inform the Project Minister if the parties have agreed on an expert to be appointed, or otherwise if there has been no such agreement; • section 224: provide a draft utility agreement that identifies the applicable matters in relation to which the parties do not agree; • section 225: make a submission to the expert in relation to the dispute; and • section 227: agree to termination or revocation of a utility agreement approved in accordance with section 226(4) of the MTPF Act. 	<ul style="list-style-type: none"> • Director General, MTIA • Chief Executive Officer, MRPV • Director, Commercial & Legal, MRPV <p>and the following class of positions:</p> <ul style="list-style-type: none"> • Director, Delivery, MRPV • Program Director, MRPV • Project Director, MRPV 	

MTPF Act			
Column 1 MTPF Act Provision	Column 2 Summary of Provision	Column 3 Delegates	Column 4 Conditions or Limitations
Sections 232, 233, 234	<p>The project authority may exercise the following project functions in relation to unnotified utility infrastructure:</p> <ul style="list-style-type: none"> • section 232: give written notice to utilities of the project authority's intention to remove, relocate or protect the infrastructure (as the case may be), and require the utility to agree to the relevant works or carry out the works itself; • section 233: if the project authority does not receive a response or the utility does not agree to the relevant works specified in a notice provided under section 232 of the MTPF Act, remove, relocate or carry out works in relation to utility infrastructure, and give the utility an estimate of costs for which the utility is liable for; and • section 234: notify the relevant utility of any damage caused to unnotified utility infrastructure, and undertake the applicable protection, relocation or removal activities in respect of utility infrastructure (including, if an emergency situation occurs, taking all reasonable steps to end the emergency). 	<ul style="list-style-type: none"> • Director General, MTIA • Chief Executive Officer, MRPV • Director, Commercial & Legal, MRPV <p>and the following class of positions:</p> <ul style="list-style-type: none"> • Director, Delivery, MRPV • Program Director, MRPV • Project Director, MRPV 	

LACA	Column 1 LACA Provision	Column 2 Summary of Provision	Column 3 Delegates	Column 4 Conditions or Limitations
Section 74 (as modified by section 118(5) of the MTPF Act)	<p>The project authority may, or may authorise another person to:</p> <ul style="list-style-type: none"> • enter and remain upon any land (with assistants, vehicles, machinery or equipment); • affix or establish any trigonometric stations, survey pegs, marks or poles; • undertake flora and fauna surveys, and archaeological investigations; and • dig or bore land, and take samples of soil, rock, ground water or minerals. 	<ul style="list-style-type: none"> • Director General, MTIA • Chief Executive Officer, MRPV • Director, Commercial & Legal, MRPV • Director, Transport Property, DOT <p>and the following class of positions:</p> <ul style="list-style-type: none"> • Director, Delivery, MRPV 	<p>To be exercised by the Director, Transport Property, DOT, unless this is not practicable.</p>	
Section 75 (as modified by section 119 of the MTPF Act)	<p>The project authority may, or may authorise another person to enter upon and occupy any land for the purposes:</p> <ul style="list-style-type: none"> • digging and taking from the land any clay, stone, gravel, earth or other substance; • depositing any material on the land; • making cuttings or excavations; • taking timber from the land; • making and using roads on the land; • manufacturing on the land any materials required; • demolishing structures (other than places of residence or business); • carrying out works on drainage channels, streams or other waterways, or works relating to the diversion of drainage channels, streams or other waterways; or • erecting temporary workshops, sheds and buildings. 	<ul style="list-style-type: none"> • Director General, MTIA • Chief Executive Officer, MRPV • Director, Commercial & Legal, MRPV • Director, Transport Property, DOT <p>and the following class of positions:</p> <ul style="list-style-type: none"> • Director, Delivery, MRPV 	<p>To be exercised by the Director, Transport Property, DOT, unless this is not practicable.</p>	

**Major Transport Projects Facilitation Act 2009, Transport Integration Act 2010 and
Land Acquisition and Compensation Act 1986**

INSTRUMENT OF DELEGATION BY SECRETARY

EPPING ROAD UPGRADE

I, Paul Younis, Secretary to the Department of Transport (**Secretary**) as project authority of the Epping Road Upgrade project (**Project**), a declared project for which designation of the project area in accordance with Part 4 of the **Major Transport Projects Facilitation Act 2009** (Vic.) (**MTPF Act**) occurred on 27 March 2020, and as project authority being also:

- taken to be specified as a determining referral authority in the Whittlesea Planning Scheme under the **Planning and Environment Act 1987** (Vic.) (**Planning and Environment Act 1987**) by operation of section 102A of the MTPF Act (**determining referral authority**); and
- the Authority for the purpose of the **Land Acquisition and Compensation Act 1986** (Vic.) (**LACA**) as applied by section 113 of the MTPF Act (**Authority**) –

in exercise of the powers vested in me under section 104 of the MTPF Act, section 39 of the **Transport Integration Act 2010** and any and all other enabling powers, hereby delegate to the person(s) from time to time employed within the Department of Transport (**DOT**) (which includes the Major Transport Infrastructure Authority, the administrative office existing in relation to DOT that is responsible for delivery of the Project (**MTIA**) and occupying the positions specified in Column 3 of the Schedule to this instrument (each a **Delegate**) such of:

- the project functions and powers conferred on me under the MTPF Act in respect of the Project;
- my powers, duties and functions as determining referral authority in relation to land in the project area; and
- my powers and functions as the Authority –

as are specified for the Delegate in Column 1 and summarised in Column 2 of the Schedule to this instrument, subject to the following conditions and limitations:

5. any condition or limitation that is specified in Column 4 of the Schedule to this instrument with respect to a power, duty or function that is specified in Column 1 of the Schedule to this instrument; and
6. the condition that the power, duty or function may only be exercised for the purpose of the Project.

If the Delegate considers that a project function is one that, in the particular circumstances, requires referral to the Secretary, then before exercising the project function the Delegate should inform and consult with the Secretary.

In the interpretation of this instrument, the summary of a provision set out in Column 2 of the Schedule to this instrument is for convenience only and, unless a contrary intention appears, does not amend, substitute or delete any part of a provision of the MTPF Act or LACA set out in Column 1 of the Schedule to this instrument or otherwise affect the scope or effect of the power, duty or function delegated.

A Delegate is not authorised to delegate or sub-delegate any power delegated under this instrument.

This delegation will remain valid until it is revoked.

The delegation I signed on 23 April 2020 delegating to persons employed within DOT certain powers, duties and functions in respect of the Project, is hereby revoked.

Dated 2 September 2020

PAUL YOUNIS
Secretary to the Department of Transport

SCHEDULE

MTPF Act			
Column 1 MTPF Act Provision	Column 2 Summary of Provision	Column 3 Delegates	Column 4 Conditions or Limitations
Section 96	The project authority may request the Planning Minister to vary the project area for the approved project.	<ul style="list-style-type: none"> • Director General, MTIA • Chief Executive Officer, Major Road Projects Victoria (MRPV) • Director, Commercial & Legal, MRPV 	
Section 101	<p>The project authority may exercise the project authority's functions, summarised as follows:</p> <ul style="list-style-type: none"> • section 101(a): facilitating development of the approved project; • sections 101(b), (c): evaluating submissions from and negotiating with interested parties; • sections 101(d), (e), (f): making recommendations in relation to, and entering and administering contractual arrangements for, development or delivery of the approved project; • sections 101(g), (h), (i): facilitating and coordinating consultations, and negotiating and entering into arrangements, and coordinating, with statutory authorities, agencies of the State and other bodies or persons involved in, or affected by, development or operation of the approved project; • section 101(i): making recommendations to the Project Minister in relation to facilitating the approved project; • section 101(j): ensuring that agreements and arrangements between the State and any other person for, or relating to, the development or delivery of the e approved project are performed in accordance with their terms; • section 101(k): commissioning transport infrastructure that is developed as part of the approved project; • section 101(l): undertaking any other functions conferred on the project authority under the MTPF Act or any other Act. 	<ul style="list-style-type: none"> • Director General, MTIA • Chief Executive Officer, MRPV • Director, Commercial & Legal, MRPV <p>and the following class of positions:</p> <ul style="list-style-type: none"> • Director, Delivery, MRPV 	

MTPF Act			
Column 1 MTPF Act Provision	Column 2 Summary of Provision	Column 3 Delegates	Column 4 Conditions or Limitations
Section 102	<p>For the purpose of performing its functions, and in addition to all other powers conferred on it by or under any other Act or law, exercising:</p> <ul style="list-style-type: none"> • section 102(1): a specified project power or power conferred on it by or under the MTPF Act; and • Section 102(2): do all other things necessary or convenient to be done for, or in connection with, or as incidental to, the performance of project functions under the MTPF Act. 	<ul style="list-style-type: none"> • Director General, MTIA • Chief Executive Officer, MRPV • Director, Commercial & Legal, MRPV • Director, Transport Property, DOT <p>and the following class of positions:</p> <ul style="list-style-type: none"> • Director, Delivery, MRPV 	
Section 102A	<p>The project authority for an approved project is taken to be specified as a determining referral authority in any planning scheme under the Planning and Environment Act.</p>	<ul style="list-style-type: none"> • Director General, MTIA • Chief Executive Officer, MRPV • Director, Commercial and Legal, MRPV <p>and the following class of positions:</p> <ul style="list-style-type: none"> • Director, Delivery, MRPV • Program Director, MRPV • Project Director, MRPV 	
Section 110	<p>On completion of an approved project, the project authority must notify the Project Minister of the project's completion.</p>	<ul style="list-style-type: none"> • Director General, MTIA • Chief Executive Officer, MRPV 	
Section 112	<p>The project authority may acquire an interest in land in the project area by agreement or by a compulsory process for the purposes of an approved project or any purpose connected with the approved project.</p>	<ul style="list-style-type: none"> • Director, Transport Property, DOT • Director General, MTIA • Chief Executive Officer, MRPV <p>and the following class of positions:</p> <ul style="list-style-type: none"> • Director, Delivery, MRPV 	<p>To be exercised by the Director, Transport Property, DOT, unless this is not practicable.</p> <p>Before acquiring an interest in any land, the delegate must give the Secretary particulars of the land and obtain the Secretary's approval in writing for the acquisition of that land.</p>

MTPF Act			
Column 1 MTPF Act Provision	Column 2 Summary of Provision	Column 3 Delegates	Column 4 Conditions or Limitations
Section 120(4), 120(5)	<p>The project authority must:</p> <ul style="list-style-type: none"> • section 120(4): make an offer for the payment of rent to the owner of the land for the authority's occupation of that land; and • section 120(5): if an amount of rent to be paid is not agreed upon, notify the Valuer-General in writing of any disagreement with an owner of land as to the amount of rent to be paid. 	<ul style="list-style-type: none"> • Director General, MTIA • Chief Executive Officer, MRPV • Director, Transport Property, DOT <p>and the following class of positions:</p> <ul style="list-style-type: none"> • Director, Delivery, MRPV 	
Section 121	<p>The project authority must:</p> <ul style="list-style-type: none"> • give the owner of land a condition report; • negotiate the contents of the condition report should the owner disagree; and • failing which, notify the Valuer General of a dispute under this section. 	<ul style="list-style-type: none"> • Director General, MTIA • Chief Executive Officer, MRPV • Director, Transport Property, DOT <p>and the following class of positions:</p> <ul style="list-style-type: none"> • Director, Delivery, MRPV • Program Director, MRPV • Project Director, MRPV 	
Section 123	<p>A project authority may transfer a building or structure in full or in part settlement of any compensation that the project authority is liable to pay.</p>	<ul style="list-style-type: none"> • Director General, MTIA • Chief Executive Officer, MRPV • Director, Transport Property, DOT 	
Section 124	<p>If a project authority acquires compulsorily under Division 1 of Part 6 to the MTPF Act part of a parcel of land owned by a person, the project authority may require that person to take as compensation land that adjoins the part of the parcel that was not acquired; and that is owned by the project authority or is surplus land.</p>	<ul style="list-style-type: none"> • Director General, MTIA • Chief Executive Officer, MRPV • Director, Transport Property, DOT 	

MTPF Act			
Column 1 MTPF Act Provision	Column 2 Summary of Provision	Column 3 Delegates	Column 4 Conditions or Limitations
Sections 127, 129	<p>The project authority is authorised to:</p> <ul style="list-style-type: none"> section 127: compulsorily acquire a native title right or interest in land in the project area for the purposes of an approved project or any purpose connected with an approved project; section 129: comply with relevant procedures under the Native Title Act 1993 (Vic.) for acquisition of native title rights and interests. 	<ul style="list-style-type: none"> Director General, MTIA Chief Executive Officer, MRPV Director, Transport Property, DOT 	<p>To be exercised by the Director, Transport Property, DOT, unless this is not practicable.</p> <p>Before acquiring a native title right or interest in land in the project area, the delegate must give the Secretary particulars of the land and obtain the Secretary's approval in writing for the acquisition of that right or interest.</p>
Section 133	<p>The project authority may purchase land outside the project area for the purposes of an approved project, or preservation, restoration or provision of native habitat.</p>	<ul style="list-style-type: none"> Director General, MTIA Chief Executive Officer, MRPV Director, Transport Property, DOT <p>and the following class of positions:</p> <ul style="list-style-type: none"> Director, Delivery, MRPV 	<p>To be exercised by the Director, Transport Property, DOT, unless this is not practicable.</p> <p>Before purchasing any land outside the project area, the delegate must give the Secretary particulars of the land and obtain the Secretary's approval in writing for the purchase of that land.</p>
Section 137B	<p>The project authority may request the consent of the Project Minister to the surrender to the Crown of land held in fee simple if the land is intended to form part of a lease of land under section 177 of the MTPF Act.</p>	<ul style="list-style-type: none"> Director General, MTIA Chief Executive Officer, MRPV Director, Transport Property, DOT 	
Section 143	<p>The project authority must notify the Minister administering the Crown Land (Reserves) Act 1978 (Vic.) of reservation of land under Subdivision 1, 2 or 2A or Division 6 of the MTPF Act.</p>	<ul style="list-style-type: none"> Director General, MTIA Chief Executive Officer, MRPV Director, Transport Property, DOT 	

MTPF Act			
Column 1 MTPF Act Provision	Column 2 Summary of Provision	Column 3 Delegates	Column 4 Conditions or Limitations
Section 147	The project authority may transfer a building or structure from project land or project authority-owned land or Council-owned land, to other land owned by the Council as compensation.	<ul style="list-style-type: none"> • Director General, MTIA • Chief Executive Officer, MRPV • Director, Transport Property, DOT 	
Section 148	The project authority may require that adjoining land is provided as compensation to Council for land acquired compulsorily.	<ul style="list-style-type: none"> • Director General, MTIA • Chief Executive Officer, MRPV • Director, Transport Property, DOT 	
Section 151	The project authority may enter into possession of project land.	<ul style="list-style-type: none"> • Director General, MTIA • Chief Executive Officer, MRPV • Director, Transport Property, DOT <p>and the following class of positions:</p> <ul style="list-style-type: none"> • Director, Delivery, MRPV 	
Section 152	The project authority must diligently endeavour to obtain agreement with the occupier of project land on terms for entry into possession of the land.	<ul style="list-style-type: none"> • Director General, MTIA • Chief Executive Officer, MRPV • Director, Transport Property, DOT <p>and the following class of positions:</p> <ul style="list-style-type: none"> • Director, Delivery, MRPV • Program Director, MRPV • Project Director, MRPV 	
Section 155(1)	The project authority may enter an agreement in relation to the time of entry into possession of project land, with the consent of the Project Minister.	<ul style="list-style-type: none"> • Coordinator General, MTIA • Chief Executive Officer, MRPV • Director, Transport Property, DOT <p>and the following class of positions:</p> <ul style="list-style-type: none"> • Director, Delivery, MRPV • Program Director, MRPV • Project Director, MRPV 	

MTPF Act			
Column 1 MTPF Act Provision	Column 2 Summary of Provision	Column 3 Delegates	Column 4 Conditions or Limitations
Section 155(3)	The project authority must serve a copy of the certificate provided under section 155(1)(a) of the MTPF Act on the occupier.	<ul style="list-style-type: none"> • Director General, MTIA • Chief Executive Officer, MRPV • Director, Transport Property, DOT <p>and the following class of positions:</p> <ul style="list-style-type: none"> • Director, Delivery, MRPV • Program Director, MRPV • Project Director, MRPV 	
Section 156	The occupation period for project land may be extended by agreement between the project authority and the occupier of the project land.	<ul style="list-style-type: none"> • Director General, MTIA • Chief Executive Officer, MRPV • Director, Transport Property, DOT <p>and the following class of positions:</p> <ul style="list-style-type: none"> • Director, Delivery, MRPV • Program Director, MRPV • Project Director, MRPV 	
Section 158	Rent payable under the applicable Subdivision of the MTPF Act may be recovered as a debt due to the project authority in any court of competent jurisdiction.	<ul style="list-style-type: none"> • Director General, MTIA • Chief Executive Officer, MRPV • Director, Transport Property, DOT • Director, Commercial & Legal, MRPV 	
Section 159	The project authority may issue a warrant to the sheriff where entitled under the applicable Division to enter into possession of project land and an occupier of project land refuses to give up possession of the land or hinders entry to that land.	<ul style="list-style-type: none"> • Director General, MTIA • Chief Executive Officer, MRPV • Director, Commercial & Legal, MRPV 	

MTPF Act			
Column 1 MTPF Act Provision	Column 2 Summary of Provision	Column 3 Delegates	Column 4 Conditions or Limitations
Section 167	<p>The project authority:</p> <ul style="list-style-type: none"> • section 167(1): may carry out or authorise works on public land inside or outside the project area for the purposes of the approved project; and • section 167(2): must notify any Minister, public authority or Council that owns or manages the public land prior to works being carried out or performed. 	<ul style="list-style-type: none"> • Director General, MTIA • Chief Executive Officer, MRPV • Director, Commercial & Legal, MRPV <p>and the following class of positions:</p> <ul style="list-style-type: none"> • Director, Delivery, MRPV • Program Director, MRPV • Project Director, MRPV 	
Section 168A	<p>The project authority may carry out or authorise associated works where an applicable approval has been granted for those works or is not required.</p>	<ul style="list-style-type: none"> • Director General, MTIA • Chief Executive Officer, MRPV • Director, Commercial & Legal, MRPV <p>and the following class of positions:</p> <ul style="list-style-type: none"> • Director, Delivery, MRPV • Program Director, MRPV • Project Director, MRPV 	
Section 170	<p>The project authority may use or authorise use of any Crown land for the purposes of an approved project.</p>	<ul style="list-style-type: none"> • Director General, MTIA • Chief Executive Officer, MRPV • Director, Commercial & Legal, MRPV <p>and the following class of positions:</p> <ul style="list-style-type: none"> • Director, Delivery, MRPV • Program Director, MRPV • Project Director, MRPV 	

MTPF Act			
Column 1 MTPF Act Provision	Column 2 Summary of Provision	Column 3 Delegates	Column 4 Conditions or Limitations
Section 171	The project authority may carry out or authorise works on any land within an easement acquired under the applicable Part of the MTPF Act.	<ul style="list-style-type: none"> • Director General, MTIA • Chief Executive Officer, MRPV • Director, Commercial & Legal, MRPV <p>and the following class of positions:</p> <ul style="list-style-type: none"> • Director, Delivery, MRPV • Program Director, MRPV • Project Director, MRPV 	
Section 171A	The project authority may transfer to a utility any easement acquired over project land for the purposes of relocating utility infrastructure as a result of an approved project.	<ul style="list-style-type: none"> • Director General, MTIA • Chief Executive Officer, MRPV • Director, Transport Property, DOT • Director, Commercial & Legal, MRPV <p>and the following class of positions:</p> <ul style="list-style-type: none"> • Director, Delivery, MRPV • Program Director, MRPV • Project Director, MRPV 	
Section 173	The project authority may issue a licence to any person to enter and use all or any part of project land that is Crown land, or land that the project authority holds in fee simple, for the purposes of the approved project.	<ul style="list-style-type: none"> • Director General, MTIA • Chief Executive Officer, MRPV • Director, Transport Property, DOT <p>and the following class of positions:</p> <ul style="list-style-type: none"> • Director, Delivery, MRPV • Program Director, MRPV • Project Director, MRPV 	
Section 184	The project authority may enter into an agreement concerning the use or development of surplus land upon or in anticipation of disposing of the whole of its interest in the land.	<ul style="list-style-type: none"> • Director General, MTIA • Chief Executive Officer, MRPV • Director, Transport Property, DOT 	

MTPF Act			
Column 1 MTPF Act Provision	Column 2 Summary of Provision	Column 3 Delegates	Column 4 Conditions or Limitations
Section 185	The project authority may sell, lease or licence any surplus land held in fee simple.	<ul style="list-style-type: none"> • Director General, MTIA • Chief Executive Officer, MRPV • Director, Transport Property, DOT 	
Section 186	<p>The project authority may:</p> <ul style="list-style-type: none"> • open, discontinue, construct, relocate or realign roads, and close any road to traffic; • carry out improvements to roads in the project area; • construct roads over or under roads constructed or to be constructed in the project area; • construct any road in the project area over or under any other roads; and • cause fences, posts, or other structures to be erected along any road constructed or to be constructed in the project area, or across any entrance, approach or means of access to, any road constructed or to be constructed in the project area. 	<ul style="list-style-type: none"> • Director General, MTIA • Chief Executive Officer, MRPV • Director, Commercial & Legal, MRPV <p>and the following class of positions:</p> <ul style="list-style-type: none"> • Director, Delivery, MRPV • Program Director, MRPV • Project Director, MRPV 	
Section 187	The project authority must advise the coordinating road authority before exercising any power under section 186.	<ul style="list-style-type: none"> • Director General, MTIA • Chief Executive Officer, MRPV • Director, Commercial & Legal, MRPV <p>and the following class of positions:</p> <ul style="list-style-type: none"> • Director, Delivery, MRPV • Program Director, MRPV • Project Director, MRPV 	

MTPF Act			
Column 1 MTPF Act Provision	Column 2 Summary of Provision	Column 3 Delegates	Column 4 Conditions or Limitations
Section 189	The project authority must cause notice of a decision under section 186 to be published in the Government Gazette and in a newspaper being circulated throughout the area affected by the decision.	<ul style="list-style-type: none"> • Director General, MTIA • Chief Executive Officer, MRPV • Director, Commercial & Legal, MRPV <p>and the following class of positions:</p> <ul style="list-style-type: none"> • Director, Delivery, MRPV • Program Director, MRPV • Project Director, MRPV 	
Section 190	The project authority may temporarily close a road to traffic for the purposes of an approved project if considered necessary to do so for works on the road or neighbouring land to be carried out.	<ul style="list-style-type: none"> • Director General, MTIA • Chief Executive Officer, MRPV • Director, Commercial & Legal, MRPV <p>and the following class of positions:</p> <ul style="list-style-type: none"> • Director, Delivery, MRPV • Program Director, MRPV • Project Director, MRPV 	
Section 196	The project authority may establish or cause to be established as a 'restricted access area' a the project area or land temporarily occupied under section 75 of the Land Acquisition Compensation Act 1986 by use of fencing, barriers, other temporary or permanent means of physical demarcation or signage on or in proximity to the area.	<ul style="list-style-type: none"> • Director General, MTIA • Chief Executive Officer, MRPV • Director, Commercial & Legal, MRPV <p>and the following class of positions:</p> <ul style="list-style-type: none"> • Director, Delivery, MRPV • Program Director, MRPV • Project Director, MRPV 	

MTPF Act			
Column 1 MTPF Act Provision	Column 2 Summary of Provision	Column 3 Delegates	Column 4 Conditions or Limitations
Section 198	The project authority must issue identity cards to authorised officers appointed for the purposes of exercising functions in respect of restricted access areas.	<ul style="list-style-type: none"> • Director General, MTIA • Chief Executive Officer, MRPV • Director, Commercial & Legal, MRPV <p>and the following class of positions:</p> <ul style="list-style-type: none"> • Director, Delivery, MRPV • Program Director, MRPV • Project Director, MRPV 	
Section 199	The project authority may, by issuing a certificate or making a declaration, authorise a person or class of person to enter and remain in a restricted access area for the purposes of preparing or conducting activities for the purposes of an approved project or carrying out ancillary activities.	<ul style="list-style-type: none"> • Director General, MTIA • Chief Executive Officer, MRPV • Director, Commercial & Legal, MRPV <p>and the following class of positions:</p> <ul style="list-style-type: none"> • Director, Delivery, MRPV • Program Director, MRPV • Project Director, MRPV 	
Sections 200, 201	The project authority may warn any person (other than owner of land or a person authorised in writing by the owner or under the MTPF Act) to leave any part of the restricted access area under the applicable Division of the MTPF Act.	<ul style="list-style-type: none"> • Director General, MTIA • Chief Executive Officer, MRPV • Director, Commercial & Legal, MRPV <p>and the following class of positions:</p> <ul style="list-style-type: none"> • Director, Delivery, MRPV • Program Director, MRPV • Project Director, MRPV 	

MTPF Act			
Column 1 MTPF Act Provision	Column 2 Summary of Provision	Column 3 Delegates	Column 4 Conditions or Limitations
Sections 211, 211A	<p>The project authority:</p> <ul style="list-style-type: none"> • section 211: must take all reasonable steps to identify all utility infrastructure, and every utility that owns such infrastructure, that may be affected by the development of the declared project; and • section 211A: may give a notice to a utility identified under section 211 of the MTPF Act requiring it state whether it owns, operates or controls the relevant utility infrastructure in the specified area, describe the nature of that infrastructure and its location, and provide plans showing the location of that infrastructure. 	<ul style="list-style-type: none"> • Director General, MTIA • Chief Executive Officer, MRPV • Director, Commercial & Legal, MRPV <p>and the following class of positions:</p> <ul style="list-style-type: none"> • Director, Delivery, MRPV • Program Director, MRPV • Project Director, MRPV 	
Section 213	<p>Following the applicable notice period, the project authority may give written notice to a utility of an intention to commence negotiations with the utility for the purpose of entering a utility agreement.</p>	<ul style="list-style-type: none"> • Director General, MTIA • Chief Executive Officer, MRPV • Director, Commercial & Legal, MRPV <p>and the following class of positions:</p> <ul style="list-style-type: none"> • Director, Delivery, MRPV • Program Director, MRPV • Project Director, MRPV 	
Section 214	<p>The project authority (and the relevant utility) must use all reasonable endeavours to negotiate a utility agreement within 50 business days after notice is given under section 213 of the MTPF Act.</p>	<ul style="list-style-type: none"> • Director General, MTIA • Chief Executive Officer, MRPV • Director, Commercial & Legal, MRPV <p>and the following class of positions:</p> <ul style="list-style-type: none"> • Director, Delivery, MRPV • Program Director, MRPV • Project Director, MRPV 	

MTPF Act	Column 1 MTPF Act Provision	Column 2 Summary of Provision	Column 3 Delegates	Column 4 Conditions or Limitations
Section 215		<p>The project authority must give written notice to the Project Minister and Utility Minister for the utility if a utility agreement is not entered into between the parties within the applicable 50 business day period.</p>	<ul style="list-style-type: none"> • Director General, MTIA • Chief Executive Officer, MRPV • Director, Commercial & Legal, MRPV <p>and the following class of positions:</p> <ul style="list-style-type: none"> • Director, Delivery, MRPV • Program Director, MRPV • Project Director, MRPV 	
Sections 216, 217, 218, 224, 225, 227		<p>The project authority may exercise the following project functions for dispute resolution and termination in relation to a utility agreement:</p> <ul style="list-style-type: none"> • section 216: give notice to the other party that a dispute exists; • section 217: use reasonable endeavours to agree on an expert for resolving the dispute; • section 218: inform the Project Minister if the parties have agreed on an expert to be appointed, or otherwise if there has been no such agreement; • section 224: provide a draft utility agreement that identifies the applicable matters in relation to which the parties do not agree; • section 225: make a submission to the expert in relation to the dispute; and • section 227: agree to termination or revocation of a utility agreement approved in accordance with section 226(4) of the MTPF Act. 	<ul style="list-style-type: none"> • Director General, MTIA • Chief Executive Officer, MRPV • Director, Commercial & Legal, MRPV <p>and the following class of positions:</p> <ul style="list-style-type: none"> • Director, Delivery, MRPV • Program Director, MRPV • Project Director, MRPV 	

MTPF Act			
Column 1 MTPF Act Provision	Column 2 Summary of Provision	Column 3 Delegates	Column 4 Conditions or Limitations
<p>Sections 232, 233, 234</p>	<p>The project authority may exercise the following project functions in relation to unnotified utility infrastructure:</p> <ul style="list-style-type: none"> • section 232: give written notice to utilities of the project authority's intention to remove, relocate or protect the infrastructure (as the case may be), and require the utility to agree to the relevant works or carry out the works itself; • section 233: if the project authority does not receive a response or the utility does not agree to the relevant works specified in a notice provided under section 232 of the MTPF Act, remove, relocate or carry out works in relation to utility infrastructure, and give the utility an estimate of costs for which the utility is liable for; and • section 234: notify the relevant utility of any damage caused to unnotified utility infrastructure, and undertake the applicable protection, relocation or removal activities in respect of utility infrastructure (including, if an emergency situation occurs, taking all reasonable steps to end the emergency). 	<ul style="list-style-type: none"> • Director General, MTIA • Chief Executive Officer, MRPV • Director, Commercial & Legal, MRPV <p>and the following class of positions:</p> <ul style="list-style-type: none"> • Director, Delivery, MRPV • Program Director, MRPV • Project Director, MRPV 	

LACA	Column 1 LACA Provision	Column 2 Summary of Provision	Column 3 Delegates	Column 4 Conditions or Limitations
Section 74 (as modified by section 118(5) of the MTPF Act)	<p>The project authority may, or may authorise another person to:</p> <ul style="list-style-type: none"> • enter and remain upon any land (with assistants, vehicles, machinery or equipment); • affix or establish any trigonometric stations, survey pegs, marks or poles; • undertake flora and fauna surveys, and archaeological investigations; and • dig or bore land, and take samples of soil, rock, ground water or minerals. 	<ul style="list-style-type: none"> • Director General, MTIA • Chief Executive Officer, MRPV • Director, Commercial & Legal, MRPV • Director, Transport Property, DOT <p>and the following class of positions:</p> <ul style="list-style-type: none"> • Director, Delivery, MRPV 	<p>To be exercised by the Director, Transport Property, DOT, unless this is not practicable.</p>	
Section 75 (as modified by section 119 of the MTPF Act)	<p>The project authority may, or may authorise another person to enter upon and occupy any land for the purposes:</p> <ul style="list-style-type: none"> • digging and taking from the land any clay, stone, gravel, earth or other substance; • depositing any material on the land; • making cuttings or excavations; • taking timber from the land; • making and using roads on the land; • manufacturing on the land any materials required; • demolishing structures (other than places of residence or business); • carrying out works on drainage channels, streams or other waterways, or works relating to the diversion of drainage channels, streams or other waterways; or • erecting temporary workshops, sheds and buildings. 	<ul style="list-style-type: none"> • Director General, MTIA • Chief Executive Officer, MRPV • Director, Commercial & Legal, MRPV • Director, Transport Property, DOT <p>and the following class of positions:</p> <ul style="list-style-type: none"> • Director, Delivery, MRPV 	<p>To be exercised by the Director, Transport Property, DOT, unless this is not practicable.</p>	

**Major Transport Projects Facilitation Act 2009, Transport Integration Act 2010 and
Land Acquisition and Compensation Act 1986**

INSTRUMENT OF DELEGATION BY SECRETARY

GOLF LINKS ROAD UPGRADE

I, Paul Younis, Secretary to the Department of Transport (**Secretary**) as project authority of the Golf Links Road Upgrade project (**Project**), a declared project for which designation of the project area in accordance with Part 4 of the **Major Transport Projects Facilitation Act 2009** (Vic.) (**MTPF Act**) occurred on 27 March 2020, and as project authority being also:

- taken to be specified as a determining referral authority in the Frankston Planning Scheme and the Mornington Peninsula Planning Scheme under the **Planning and Environment Act 1987** (Vic.) (**Planning and Environment Act 1987**) by operation of section 102A of the MTPF Act (**determining referral authority**); and
- the Authority for the purpose of the **Land Acquisition and Compensation Act 1986** (Vic.) (**LACA**) as applied by section 113 of the MTPF Act (**Authority**) –

in exercise of the powers vested in me under section 104 of the MTPF Act, section 39 of the **Transport Integration Act 2010** and any and all other enabling powers, hereby delegate to the person(s) from time to time employed within the Department of Transport (**DOT**) (which includes the Major Transport Infrastructure Authority, the administrative office existing in relation to DOT that is responsible for delivery of the Project (**MTIA**) and occupying the positions specified in Column 3 of the Schedule to this instrument (each a **Delegate**) such of:

- the project functions and powers conferred on me under the MTPF Act in respect of the Project;
- my powers, duties and functions as determining referral authority in relation to land in the project area; and
- my powers and functions as the Authority –

as are specified for the Delegate in Column 1 and summarised in Column 2 of the Schedule to this instrument, subject to the following conditions and limitations:

23. any condition or limitation that is specified in Column 4 of the Schedule to this instrument with respect to a power, duty or function that is specified in Column 1 of the Schedule to this instrument; and
24. the condition that the power, duty or function may only be exercised for the purpose of the Project.

If the Delegate considers that a project function is one that, in the particular circumstances, requires referral to the Secretary, then before exercising the project function the Delegate should inform and consult with the Secretary.

In the interpretation of this instrument, the summary of a provision set out in Column 2 of the Schedule to this instrument is for convenience only and, unless a contrary intention appears, does not amend, substitute or delete any part of a provision of the MTPF Act or LACA set out in Column 1 of the Schedule to this instrument or otherwise affect the scope or effect of the power, duty or function delegated.

A Delegate is not authorised to delegate or sub-delegate any power delegated under this instrument.

This delegation will remain valid until it is revoked.

The delegation I signed on 23 April 2020 delegating to persons employed within DOT certain powers, duties and functions in respect of the Project, is hereby revoked.

Dated 2 September 2020

PAUL YOUNIS
Secretary to the Department of Transport

SCHEDULE

MTPF Act			
Column 1 MTPF Act Provision	Column 2 Summary of Provision	Column 3 Delegates	Column 4 Conditions or Limitations
Section 96	The project authority may request the Planning Minister to vary the project area for the approved project.	<ul style="list-style-type: none"> • Director General, MTIA • Chief Executive Officer, Major Road Projects Victoria (MRPV) • Director, Commercial & Legal, MRPV 	
Section 101	<p>The project authority may exercise the project authority's functions, summarised as follows:</p> <ul style="list-style-type: none"> • section 101(a): facilitating development of the approved project; • sections 101(b), (c): evaluating submissions from and negotiating with interested parties; • sections 101(d), (e), (f): making recommendations in relation to, and entering and administering contractual arrangements for, development or delivery of the approved project; • sections 101(g), (h), (i): facilitating and coordinating consultations, and negotiating and entering into arrangements, and coordinating, with statutory authorities, agencies of the State and other bodies or persons involved in, or affected by, development or operation of the approved project; • section 101(i): making recommendations to the Project Minister in relation to facilitating the approved project; • section 101(j): ensuring that agreements and arrangements between the State and any other person for, or relating to, the development or delivery of the approved project are performed in accordance with their terms; • section 101(k): commissioning transport infrastructure that is developed as part of the approved project; • section 101(l): undertaking any other functions conferred on the project authority under the MTPF Act or any other Act. 	<ul style="list-style-type: none"> • Director General, MTIA • Chief Executive Officer, MRPV • Director, Commercial & Legal, MRPV <p>and the following class of positions:</p> <ul style="list-style-type: none"> • Director, Delivery, MRPV 	

MTPF Act			
Column 1 MTPF Act Provision	Column 2 Summary of Provision	Column 3 Delegates	Column 4 Conditions or Limitations
Section 102	<p>For the purpose of performing its functions, and in addition to all other powers conferred on it by or under any other Act or law, exercising:</p> <ul style="list-style-type: none"> • section 102(1): a specified project power or power conferred on it by or under the MTPF Act; and • Section 102(2): do all other things necessary or convenient to be done for, or in connection with, or as incidental to, the performance of project functions under the MTPF Act. 	<ul style="list-style-type: none"> • Director General, MTIA • Chief Executive Officer, MRPV • Director, Commercial & Legal, MRPV • Director, Transport Property, DOT <p>and the following class of positions:</p> <ul style="list-style-type: none"> • Director, Delivery, MRPV 	
Section 102A	<p>The project authority for an approved project is taken to be specified as a determining referral authority in any planning scheme under the Planning and Environment Act.</p>	<ul style="list-style-type: none"> • Director General, MTIA • Chief Executive Officer, MRPV • Director, Commercial and Legal, MRPV <p>and the following class of positions:</p> <ul style="list-style-type: none"> • Director, Delivery, MRPV • Program Director, MRPV • Project Director, MRPV 	
Section 110	<p>On completion of an approved project, the project authority must notify the Project Minister of the project's completion.</p>	<ul style="list-style-type: none"> • Director General, MTIA • Chief Executive Officer, MRPV 	
Section 112	<p>The project authority may acquire an interest in land in the project area by agreement or by a compulsory process for the purposes of an approved project or any purpose connected with the approved project.</p>	<ul style="list-style-type: none"> • Director, Transport Property, DOT • Director General, MTIA • Chief Executive Officer, MRPV <p>and the following class of positions:</p> <ul style="list-style-type: none"> • Director, Delivery, MRPV 	<p>To be exercised by the Director, Transport Property, DOT, unless this is not practicable.</p> <p>Before acquiring an interest in any land, the delegate must give the Secretary particulars of the land and obtain the Secretary's approval in writing for the acquisition of that land.</p>

MTPF Act			
Column 1 MTPF Act Provision	Column 2 Summary of Provision	Column 3 Delegates	Column 4 Conditions or Limitations
Section 120(4), 120(5)	<p>The project authority must:</p> <ul style="list-style-type: none"> • section 120(4): make an offer for the payment of rent to the owner of the land for the authority's occupation of that land; and • section 120(5): if an amount of rent to be paid is not agreed upon, notify the Valuer-General in writing of any disagreement with an owner of land as to the amount of rent to be paid. 	<ul style="list-style-type: none"> • Director General, MTIA • Chief Executive Officer, MRPV • Director, Transport Property, DOT <p>and the following class of positions:</p> <ul style="list-style-type: none"> • Director, Delivery, MRPV 	
Section 121	<p>The project authority must:</p> <ul style="list-style-type: none"> • give the owner of land a condition report; • negotiate the contents of the condition report should the owner disagree; and • failing which, notify the Valuer General of a dispute under this section. 	<ul style="list-style-type: none"> • Director General, MTIA • Chief Executive Officer, MRPV • Director, Transport Property, DOT <p>and the following class of positions:</p> <ul style="list-style-type: none"> • Director, Delivery, MRPV • Program Director, MRPV • Project Director, MRPV 	
Section 123	<p>A project authority may transfer a building or structure in full or in part settlement of any compensation that the project authority is liable to pay.</p>	<ul style="list-style-type: none"> • Director General, MTIA • Chief Executive Officer, MRPV • Director, Transport Property, DOT 	
Section 124	<p>If a project authority acquires compulsorily under Division 1 of Part 6 to the MTPF Act part of a parcel of land owned by a person, the project authority may require that person to take as compensation land that adjoins the part of the parcel that was not acquired; and that is owned by the project authority or is surplus land.</p>	<ul style="list-style-type: none"> • Director General, MTIA • Chief Executive Officer, MRPV • Director, Transport Property, DOT 	

MTPF Act			
Column 1 MTPF Act Provision	Column 2 Summary of Provision	Column 3 Delegates	Column 4 Conditions or Limitations
Sections 127, 129	<p>The project authority is authorised to:</p> <ul style="list-style-type: none"> section 127: compulsorily acquire a native title right or interest in land in the project area for the purposes of an approved project or any purpose connected with an approved project; section 129: comply with relevant procedures under the Native Title Act 1993 (Vic.) for acquisition of native title rights and interests. 	<ul style="list-style-type: none"> Director General, MTIA Chief Executive Officer, MRPV Director, Transport Property, DOT 	<p>To be exercised by the Director, Transport Property, DOT, unless this is not practicable.</p> <p>Before acquiring a native title right or interest in land in the project area, the delegate must give the Secretary particulars of the land and obtain the Secretary's approval in writing for the acquisition of that right or interest.</p>
Section 133	<p>The project authority may purchase land outside the project area for the purposes of an approved project, or preservation, restoration or provision of native habitat.</p>	<ul style="list-style-type: none"> Director General, MTIA Chief Executive Officer, MRPV Director, Transport Property, DOT <p>and the following class of positions:</p> <ul style="list-style-type: none"> Director, Delivery, MRPV 	<p>To be exercised by the Director, Transport Property, DOT, unless this is not practicable.</p> <p>Before purchasing any land outside the project area, the delegate must give the Secretary particulars of the land and obtain the Secretary's approval in writing for the purchase of that land.</p>
Section 137B	<p>The project authority may request the consent of the Project Minister to the surrender to the Crown of land held in fee simple if the land is intended to form part of a lease of land under section 177 of the MTPF Act.</p>	<ul style="list-style-type: none"> Director General, MTIA Chief Executive Officer, MRPV Director, Transport Property, DOT 	
Section 143	<p>The project authority must notify the Minister administering the Crown Land (Reserves) Act 1978 (Vic.) of reservation of land under Subdivision 1, 2 or 2A or Division 6 of the MTPF Act.</p>	<ul style="list-style-type: none"> Director General, MTIA Chief Executive Officer, MRPV Director, Transport Property, DOT 	

MTPF Act			
Column 1 MTPF Act Provision	Column 2 Summary of Provision	Column 3 Delegates	Column 4 Conditions or Limitations
Section 147	The project authority may transfer a building or structure from project land or project authority-owned land or Council-owned land, to other land owned by the Council as compensation.	<ul style="list-style-type: none"> • Director General, MTIA • Chief Executive Officer, MRPV • Director, Transport Property, DOT 	
Section 148	The project authority may require that adjoining land is provided as compensation to Council for land acquired compulsorily.	<ul style="list-style-type: none"> • Director General, MTIA • Chief Executive Officer, MRPV • Director, Transport Property, DOT 	
Section 151	The project authority may enter into possession of project land.	<ul style="list-style-type: none"> • Director General, MTIA • Chief Executive Officer, MRPV • Director, Transport Property, DOT <p>and the following class of positions:</p> <ul style="list-style-type: none"> • Director, Delivery, MRPV 	
Section 152	The project authority must diligently endeavour to obtain agreement with the occupier of project land on terms for entry into possession of the land.	<ul style="list-style-type: none"> • Director General, MTIA • Chief Executive Officer, MRPV • Director, Transport Property, DOT <p>and the following class of positions:</p> <ul style="list-style-type: none"> • Director, Delivery, MRPV • Program Director, MRPV • Project Director, MRPV 	
Section 155(1)	The project authority may enter an agreement in relation to the time of entry into possession of project land, with the consent of the Project Minister.	<ul style="list-style-type: none"> • Coordinator General, MTIA • Chief Executive Officer, MRPV • Director, Transport Property, DOT <p>and the following class of positions:</p> <ul style="list-style-type: none"> • Director, Delivery, MRPV • Program Director, MRPV • Project Director, MRPV 	

MTPF Act			
Column 1 MTPF Act Provision	Column 2 Summary of Provision	Column 3 Delegates	Column 4 Conditions or Limitations
Section 155(3)	The project authority must serve a copy of the certificate provided under section 155(1)(a) of the MTPF Act on the occupier.	<ul style="list-style-type: none"> • Director General, MTIA • Chief Executive Officer, MRPV • Director, Transport Property, DOT <p>and the following class of positions:</p> <ul style="list-style-type: none"> • Director, Delivery, MRPV • Program Director, MRPV • Project Director, MRPV 	
Section 156	The occupation period for project land may be extended by agreement between the project authority and the occupier of the project land.	<ul style="list-style-type: none"> • Director General, MTIA • Chief Executive Officer, MRPV • Director, Transport Property, DOT <p>and the following class of positions:</p> <ul style="list-style-type: none"> • Director, Delivery, MRPV • Program Director, MRPV • Project Director, MRPV 	
Section 158	Rent payable under the applicable Subdivision of the MTPF Act may be recovered as a debt due to the project authority in any court of competent jurisdiction.	<ul style="list-style-type: none"> • Director General, MTIA • Chief Executive Officer, MRPV • Director, Transport Property, DOT • Director, Commercial & Legal, MRPV 	
Section 159	The project authority may issue a warrant to the sheriff where entitled under the applicable Division to enter into possession of project land and an occupier of project land refuses to give up possession of the land or hinders entry to that land.	<ul style="list-style-type: none"> • Director General, MTIA • Chief Executive Officer, MRPV • Director, Commercial & Legal, MRPV 	

MTPF Act			
Column 1 MTPF Act Provision	Column 2 Summary of Provision	Column 3 Delegates	Column 4 Conditions or Limitations
Section 167	<p>The project authority:</p> <ul style="list-style-type: none"> • section 167(1): may carry out or authorise works on public land inside or outside the project area for the purposes of the approved project; and • section 167(2): must notify any Minister, public authority or Council that owns or manages the public land prior to works being carried out or performed. 	<ul style="list-style-type: none"> • Director General, MTIA • Chief Executive Officer, MRPV • Director, Commercial & Legal, MRPV <p>and the following class of positions:</p> <ul style="list-style-type: none"> • Director, Delivery, MRPV • Program Director, MRPV • Project Director, MRPV 	
Section 168A	<p>The project authority may carry out or authorise associated works where an applicable approval has been granted for those works or is not required.</p>	<ul style="list-style-type: none"> • Director General, MTIA • Chief Executive Officer, MRPV • Director, Commercial & Legal, MRPV <p>and the following class of positions:</p> <ul style="list-style-type: none"> • Director, Delivery, MRPV • Program Director, MRPV • Project Director, MRPV 	
Section 170	<p>The project authority may use or authorise use of any Crown land for the purposes of an approved project.</p>	<ul style="list-style-type: none"> • Director General, MTIA • Chief Executive Officer, MRPV • Director, Commercial & Legal, MRPV <p>and the following class of positions:</p> <ul style="list-style-type: none"> • Director, Delivery, MRPV • Program Director, MRPV • Project Director, MRPV 	

MTPF Act			
Column 1 MTPF Act Provision	Column 2 Summary of Provision	Column 3 Delegates	Column 4 Conditions or Limitations
Section 171	The project authority may carry out or authorise works on any land within an easement acquired under the applicable Part of the MTPF Act.	<ul style="list-style-type: none"> • Director General, MTIA • Chief Executive Officer, MRPV • Director, Commercial & Legal, MRPV <p>and the following class of positions:</p> <ul style="list-style-type: none"> • Director, Delivery, MRPV • Program Director, MRPV • Project Director, MRPV 	
Section 171A	The project authority may transfer to a utility any easement acquired over project land for the purposes of relocating utility infrastructure as a result of an approved project.	<ul style="list-style-type: none"> • Director General, MTIA • Chief Executive Officer, MRPV • Director, Transport Property, DOT • Director, Commercial & Legal, MRPV <p>and the following class of positions:</p> <ul style="list-style-type: none"> • Director, Delivery, MRPV • Program Director, MRPV • Project Director, MRPV 	
Section 173	The project authority may issue a licence to any person to enter and use all or any part of project land that is Crown land, or land that the project authority holds in fee simple, for the purposes of the approved project.	<ul style="list-style-type: none"> • Director General, MTIA • Chief Executive Officer, MRPV • Director, Transport Property, DOT <p>and the following class of positions:</p> <ul style="list-style-type: none"> • Director, Delivery, MRPV • Program Director, MRPV • Project Director, MRPV 	
Section 184	The project authority may enter into an agreement concerning the use or development of surplus land upon or in anticipation of disposing of the whole of its interest in the land.	<ul style="list-style-type: none"> • Director General, MTIA • Chief Executive Officer, MRPV • Director, Transport Property, DOT 	

MTPF Act			
Column 1 MTPF Act Provision	Column 2 Summary of Provision	Column 3 Delegates	Column 4 Conditions or Limitations
Section 185	The project authority may sell, lease or licence any surplus land held in fee simple.	<ul style="list-style-type: none"> • Director General, MTIA • Chief Executive Officer, MRPV • Director, Transport Property, DOT 	
Section 186	<p>The project authority may:</p> <ul style="list-style-type: none"> • open, discontinue, construct, relocate or realign roads, and close any road to traffic; • carry out improvements to roads in the project area; • construct roads over or under roads constructed or to be constructed in the project area; • construct any road in the project area over or under any other roads; and • cause fences, posts, or other structures to be erected along any road constructed or to be constructed in the project area, or across any entrance, approach or means of access to, any road constructed or to be constructed in the project area. 	<ul style="list-style-type: none"> • Director General, MTIA • Chief Executive Officer, MRPV • Director, Commercial & Legal, MRPV <p>and the following class of positions:</p> <ul style="list-style-type: none"> • Director, Delivery, MRPV • Program Director, MRPV • Project Director, MRPV 	
Section 187	The project authority must advise the coordinating road authority before exercising any power under section 186.	<ul style="list-style-type: none"> • Director General, MTIA • Chief Executive Officer, MRPV • Director, Commercial & Legal, MRPV <p>and the following class of positions:</p> <ul style="list-style-type: none"> • Director, Delivery, MRPV • Program Director, MRPV • Project Director, MRPV 	

MTPF Act			
Column 1 MTPF Act Provision	Column 2 Summary of Provision	Column 3 Delegates	Column 4 Conditions or Limitations
Section 189	<p>The project authority must cause notice of a decision under section 186 to be published in the Government Gazette and in a newspaper being circulated throughout the area affected by the decision.</p>	<ul style="list-style-type: none"> • Director General, MTIA • Chief Executive Officer, MRPV • Director, Commercial & Legal, MRPV <p>and the following class of positions:</p> <ul style="list-style-type: none"> • Director, Delivery, MRPV • Program Director, MRPV • Project Director, MRPV 	
Section 190	<p>The project authority may temporarily close a road to traffic for the purposes of an approved project if considered necessary to do so for works on the road or neighbouring land to be carried out.</p>	<ul style="list-style-type: none"> • Director General, MTIA • Chief Executive Officer, MRPV • Director, Commercial & Legal, MRPV <p>and the following class of positions:</p> <ul style="list-style-type: none"> • Director, Delivery, MRPV • Program Director, MRPV • Project Director, MRPV 	
Section 196	<p>The project authority may establish or cause to be established as a 'restricted access area' a the project area or land temporarily occupied under section 75 of the Land Acquisition Compensation Act 1986 by use of fencing, barriers, other temporary or permanent means of physical demarcation or signage on or in proximity to the area.</p>	<ul style="list-style-type: none"> • Director General, MTIA • Chief Executive Officer, MRPV • Director, Commercial & Legal, MRPV <p>and the following class of positions:</p> <ul style="list-style-type: none"> • Director, Delivery, MRPV • Program Director, MRPV • Project Director, MRPV 	

MTPF Act			
Column 1 MTPF Act Provision	Column 2 Summary of Provision	Column 3 Delegates	Column 4 Conditions or Limitations
Section 198	The project authority must issue identity cards to authorised officers appointed for the purposes of exercising functions in respect of restricted access areas.	<ul style="list-style-type: none"> • Director General, MTIA • Chief Executive Officer, MRPV • Director, Commercial & Legal, MRPV <p>and the following class of positions:</p> <ul style="list-style-type: none"> • Director, Delivery, MRPV • Program Director, MRPV • Project Director, MRPV 	
Section 199	The project authority may, by issuing a certificate or making a declaration, authorise a person or class of person to enter and remain in a restricted access area for the purposes of preparing or conducting activities for the purposes of an approved project or carrying out ancillary activities.	<ul style="list-style-type: none"> • Director General, MTIA • Chief Executive Officer, MRPV • Director, Commercial & Legal, MRPV <p>and the following class of positions:</p> <ul style="list-style-type: none"> • Director, Delivery, MRPV • Program Director, MRPV • Project Director, MRPV 	
Sections 200, 201	The project authority may warn any person (other than owner of land or a person authorised in writing by the owner or under the MTPF Act) to leave any part of the restricted access area under the applicable Division of the MTPF Act.	<ul style="list-style-type: none"> • Director General, MTIA • Chief Executive Officer, MRPV • Director, Commercial & Legal, MRPV <p>and the following class of positions:</p> <ul style="list-style-type: none"> • Director, Delivery, MRPV • Program Director, MRPV • Project Director, MRPV 	

MTPF Act			
Column 1 MTPF Act Provision	Column 2 Summary of Provision	Column 3 Delegates	Column 4 Conditions or Limitations
Sections 211, 211A	<p>The project authority:</p> <ul style="list-style-type: none"> section 211: must take all reasonable steps to identify all utility infrastructure, and every utility that owns such infrastructure, that may be affected by the development of the declared project; and section 211A: may give a notice to a utility identified under section 211 of the MTPF Act requiring it state whether it owns, operates or controls the relevant utility infrastructure in the specified area, describe the nature of that infrastructure and its location, and provide plans showing the location of that infrastructure. 	<ul style="list-style-type: none"> Director General, MTIA Chief Executive Officer, MRPV Director, Commercial & Legal, MRPV <p>and the following class of positions:</p> <ul style="list-style-type: none"> Director, Delivery, MRPV Program Director, MRPV Project Director, MRPV 	
Section 213	<p>Following the applicable notice period, the project authority may give written notice to a utility of an intention to commence negotiations with the utility for the purpose of entering a utility agreement.</p>	<ul style="list-style-type: none"> Director General, MTIA Chief Executive Officer, MRPV Director, Commercial & Legal, MRPV <p>and the following class of positions:</p> <ul style="list-style-type: none"> Director, Delivery, MRPV Program Director, MRPV Project Director, MRPV 	
Section 214	<p>The project authority (and the relevant utility) must use all reasonable endeavours to negotiate a utility agreement within 50 business days after notice is given under section 213 of the MTPF Act.</p>	<ul style="list-style-type: none"> Director General, MTIA Chief Executive Officer, MRPV Director, Commercial & Legal, MRPV <p>and the following class of positions:</p> <ul style="list-style-type: none"> Director, Delivery, MRPV Program Director, MRPV Project Director, MRPV 	

MTPF Act			
Column 1 MTPF Act Provision	Column 2 Summary of Provision	Column 3 Delegates	Column 4 Conditions or Limitations
Section 215	The project authority must give written notice to the Project Minister and Utility Minister for the utility if a utility agreement is not entered into between the parties within the applicable 50 business day period.	<ul style="list-style-type: none"> • Director General, MTIA • Chief Executive Officer, MRPV • Director, Commercial & Legal, MRPV <p>and the following class of positions:</p> <ul style="list-style-type: none"> • Director, Delivery, MRPV • Program Director, MRPV • Project Director, MRPV 	
Sections 216, 217, 218, 224, 225, 227	<p>The project authority may exercise the following project functions for dispute resolution and termination in relation to a utility agreement:</p> <ul style="list-style-type: none"> • section 216: give notice to the other party that a dispute exists; • section 217: use reasonable endeavours to agree on an expert for resolving the dispute; • section 218: inform the Project Minister if the parties have agreed on an expert to be appointed, or otherwise if there has been no such agreement; • section 224: provide a draft utility agreement that identifies the applicable matters in relation to which the parties do not agree; • section 225: make a submission to the expert in relation to the dispute; and • section 227: agree to termination or revocation of a utility agreement approved in accordance with section 226(4) of the MTPF Act. 	<ul style="list-style-type: none"> • Director General, MTIA • Chief Executive Officer, MRPV • Director, Commercial & Legal, MRPV <p>and the following class of positions:</p> <ul style="list-style-type: none"> • Director, Delivery, MRPV • Program Director, MRPV • Project Director, MRPV 	

MTPF Act			
Column 1 MTPF Act Provision	Column 2 Summary of Provision	Column 3 Delegates	Column 4 Conditions or Limitations
<p>Sections 232, 233, 234</p>	<p>The project authority may exercise the following project functions in relation to unnotified utility infrastructure:</p> <ul style="list-style-type: none"> • section 232: give written notice to utilities of the project authority's intention to remove, relocate or protect the infrastructure (as the case may be), and require the utility to agree to the relevant works or carry out the works itself; • section 233: if the project authority does not receive a response or the utility does not agree to the relevant works specified in a notice provided under section 232 of the MTPF Act, remove, relocate or carry out works in relation to utility infrastructure, and give the utility an estimate of costs for which the utility is liable for; and • section 234: notify the relevant utility of any damage caused to unnotified utility infrastructure, and undertake the applicable protection, relocation or removal activities in respect of utility infrastructure (including, if an emergency situation occurs, taking all reasonable steps to end the emergency). 	<ul style="list-style-type: none"> • Director General, MTIA • Chief Executive Officer, MRPV • Director, Commercial & Legal, MRPV <p>and the following class of positions:</p> <ul style="list-style-type: none"> • Director, Delivery, MRPV • Program Director, MRPV • Project Director, MRPV 	

LACA	Column 1 LACA Provision	Column 2 Summary of Provision	Column 3 Delegates	Column 4 Conditions or Limitations
Section 74 (as modified by section 118(5) of the MTPF Act)	The project authority may, or may authorise another person to: <ul style="list-style-type: none"> • enter and remain upon any land (with assistants, vehicles, machinery or equipment); • affix or establish any trigonometric stations, survey pegs, marks or poles; • undertake flora and fauna surveys, and archaeological investigations; and • dig or bore land, and take samples of soil, rock, ground water or minerals. 	<ul style="list-style-type: none"> • Director General, MTIA • Chief Executive Officer, MRPV • Director, Commercial & Legal, MRPV • Director, Transport Property, DOT <p>and the following class of positions:</p> <ul style="list-style-type: none"> • Director, Delivery, MRPV 	To be exercised by the Director, Transport Property, DOT, unless this is not practicable.	
Section 75 (as modified by section 119 of the MTPF Act)	The project authority may, or may authorise another person to enter upon and occupy any land for the purposes: <ul style="list-style-type: none"> • digging and taking from the land any clay, stone, gravel, earth or other substance; • depositing any material on the land; • making cuttings or excavations; • taking timber from the land; • making and using roads on the land; • manufacturing on the land any materials required; • demolishing structures (other than places of residence or business); • carrying out works on drainage channels, streams or other waterways, or works relating to the diversion of drainage channels, streams or other waterways; or • erecting temporary workshops, sheds and buildings. 	<ul style="list-style-type: none"> • Director General, MTIA • Chief Executive Officer, MRPV • Director, Commercial & Legal, MRPV • Director, Transport Property, DOT <p>and the following class of positions:</p> <ul style="list-style-type: none"> • Director, Delivery, MRPV 	To be exercised by the Director, Transport Property, DOT, unless this is not practicable.	

**Major Transport Projects Facilitation Act 2009, Transport Integration Act 2010 and
Land Acquisition and Compensation Act 1986**

INSTRUMENT OF DELEGATION BY SECRETARY

HEALESVILLE–KOO WEE RUP ROAD UPGRADE

I, Paul Younis, Secretary to the Department of Transport (**Secretary**) as project authority of the Healesville–Koo Wee Rup Road Upgrade project (**Project**), a declared project for which designation of the project area in accordance with Part 4 of the **Major Transport Projects Facilitation Act 2009** (Vic.) (**MTPF Act**) occurred on 27 March 2020, and as project authority being also:

- taken to be specified as a determining referral authority in the Cardinia Planning Scheme under the **Planning and Environment Act 1987** (Vic.) (**Planning and Environment Act 1987**) by operation of section 102A of the MTPF Act (**determining referral authority**); and
- the Authority for the purpose of the **Land Acquisition and Compensation Act 1986** (Vic.) (**LACA**) as applied by section 113 of the MTPF Act (**Authority**) –

in exercise of the powers vested in me under section 104 of the MTPF Act, section 39 of the **Transport Integration Act 2010** and any and all other enabling powers, hereby delegate to the person(s) from time to time employed within the Department of Transport (**DOT**) (which includes the Major Transport Infrastructure Authority, the administrative office existing in relation to DOT that is responsible for delivery of the Project (**MTIA**) and occupying the positions specified in Column 3 of the Schedule to this instrument (each a **Delegate**) such of:

- the project functions and powers conferred on me under the MTPF Act in respect of the Project;
- my powers, duties and functions as determining referral authority in relation to land in the project area; and
- my powers and functions as the Authority –

as are specified for the Delegate in Column 1 and summarised in Column 2 of the Schedule to this instrument, subject to the following conditions and limitations:

13. any condition or limitation that is specified in Column 4 of the Schedule to this instrument with respect to a power, duty or function that is specified in Column 1 of the Schedule to this instrument; and
14. the condition that the power, duty or function may only be exercised for the purpose of the Project.

If the Delegate considers that a project function is one that, in the particular circumstances, requires referral to the Secretary, then before exercising the project function the Delegate should inform and consult with the Secretary.

In the interpretation of this instrument, the summary of a provision set out in Column 2 of the Schedule to this instrument is for convenience only and, unless a contrary intention appears, does not amend, substitute or delete any part of a provision of the MTPF Act or LACA set out in Column 1 of the Schedule to this instrument or otherwise affect the scope or effect of the power, duty or function delegated.

A Delegate is not authorised to delegate or sub-delegate any power delegated under this instrument.

This delegation will remain valid until it is revoked.

The delegation I signed on 23 April 2020 delegating to persons employed within DOT certain powers, duties and functions in respect of the Project, is hereby revoked.

Dated 2 September 2020

PAUL YOUNIS
Secretary to the Department of Transport

SCHEDULE

MTPF Act			
Column 1 MTPF Act Provision	Column 2 Summary of Provision	Column 3 Delegates	Column 4 Conditions or Limitations
Section 96	The project authority may request the Planning Minister to vary the project area for the approved project.	<ul style="list-style-type: none"> • Director General, MTIA • Chief Executive Officer, Major Road Projects Victoria (MRPV) • Director, Commercial & Legal, MRPV 	
Section 101	<p>The project authority may exercise the project authority's functions, summarised as follows:</p> <ul style="list-style-type: none"> • section 101(a): facilitating development of the approved project; • sections 101(b), (c): evaluating submissions from and negotiating with interested parties; • sections 101(d), (e), (f): making recommendations in relation to, and entering and administering contractual arrangements for, development or delivery of the approved project; • sections 101(g), (h), (i): facilitating and coordinating consultations, and negotiating and entering into arrangements, and coordinating, with statutory authorities, agencies of the State and other bodies or persons involved in, or affected by, development or operation of the approved project; • section 101(i): making recommendations to the Project Minister in relation to facilitating the approved project; • section 101(j): ensuring that agreements and arrangements between the State and any other person for, or relating to, the development or delivery of the e approved project are performed in accordance with their terms; • section 101(k): commissioning transport infrastructure that is developed as part of the approved project; • section 101(l): undertaking any other functions conferred on the project authority under the MTPF Act or any other Act. 	<ul style="list-style-type: none"> • Director General, MTIA • Chief Executive Officer, MRPV • Director, Commercial & Legal, MRPV <p>and the following class of positions:</p> <ul style="list-style-type: none"> • Director, Delivery, MRPV 	

MTPF Act			
Column 1 MTPF Act Provision	Column 2 Summary of Provision	Column 3 Delegates	Column 4 Conditions or Limitations
Section 102	<p>For the purpose of performing its functions, and in addition to all other powers conferred on it by or under any other Act or law, exercising:</p> <ul style="list-style-type: none"> • section 102(1): a specified project power or power conferred on it by or under the MTPF Act; and • Section 102(2): do all other things necessary or convenient to be done for, or in connection with, or as incidental to, the performance of project functions under the MTPF Act. 	<ul style="list-style-type: none"> • Director General, MTIA • Chief Executive Officer, MRPV • Director, Commercial & Legal, MRPV • Director, Transport Property, DOT <p>and the following class of positions:</p> <ul style="list-style-type: none"> • Director, Delivery, MRPV 	
Section 102A	<p>The project authority for an approved project is taken to be specified as a determining referral authority in any planning scheme under the Planning and Environment Act.</p>	<ul style="list-style-type: none"> • Director General, MTIA • Chief Executive Officer, MRPV • Director, Commercial and Legal, MRPV <p>and the following class of positions:</p> <ul style="list-style-type: none"> • Director, Delivery, MRPV • Program Director, MRPV • Project Director, MRPV 	
Section 110	<p>On completion of an approved project, the project authority must notify the Project Minister of the project's completion.</p>	<ul style="list-style-type: none"> • Director General, MTIA • Chief Executive Officer, MRPV 	
Section 112	<p>The project authority may acquire an interest in land in the project area by agreement or by a compulsory process for the purposes of an approved project or any purpose connected with the approved project.</p>	<ul style="list-style-type: none"> • Director, Transport Property, DOT • Director General, MTIA • Chief Executive Officer, MRPV <p>and the following class of positions:</p> <ul style="list-style-type: none"> • Director, Delivery, MRPV 	<p>To be exercised by the Director, Transport Property, DOT, unless this is not practicable.</p> <p>Before acquiring an interest in any land, the delegate must give the Secretary particulars of the land and obtain the Secretary's approval in writing for the acquisition of that land.</p>

MTPF Act			
Column 1 MTPF Act Provision	Column 2 Summary of Provision	Column 3 Delegates	Column 4 Conditions or Limitations
Section 120(4), 120(5)	<p>The project authority must:</p> <ul style="list-style-type: none"> • section 120(4): make an offer for the payment of rent to the owner of the land for the authority's occupation of that land; and • section 120(5): if an amount of rent to be paid is not agreed upon, notify the Valuer-General in writing of any disagreement with an owner of land as to the amount of rent to be paid. 	<ul style="list-style-type: none"> • Director General, MTIA • Chief Executive Officer, MRPV • Director, Transport Property, DOT <p>and the following class of positions:</p> <ul style="list-style-type: none"> • Director, Delivery, MRPV 	
Section 121	<p>The project authority must:</p> <ul style="list-style-type: none"> • give the owner of land a condition report; • negotiate the contents of the condition report should the owner disagree; and • failing which, notify the Valuer General of a dispute under this section. 	<ul style="list-style-type: none"> • Director General, MTIA • Chief Executive Officer, MRPV • Director, Transport Property, DOT <p>and the following class of positions:</p> <ul style="list-style-type: none"> • Director, Delivery, MRPV • Program Director, MRPV • Project Director, MRPV 	
Section 123	<p>A project authority may transfer a building or structure in full or in part settlement of any compensation that the project authority is liable to pay.</p>	<ul style="list-style-type: none"> • Director General, MTIA • Chief Executive Officer, MRPV • Director, Transport Property, DOT 	
Section 124	<p>If a project authority acquires compulsorily under Division 1 of Part 6 to the MTPF Act part of a parcel of land owned by a person, the project authority may require that person to take as compensation land that adjoins the part of the parcel that was not acquired; and that is owned by the project authority or is surplus land.</p>	<ul style="list-style-type: none"> • Director General, MTIA • Chief Executive Officer, MRPV • Director, Transport Property, DOT 	

MTPF Act			
Column 1 MTPF Act Provision	Column 2 Summary of Provision	Column 3 Delegates	Column 4 Conditions or Limitations
Sections 127, 129	<p>The project authority is authorised to:</p> <ul style="list-style-type: none"> section 127: compulsorily acquire a native title right or interest in land in the project area for the purposes of an approved project or any purpose connected with an approved project; section 129: comply with relevant procedures under the Native Title Act 1993 (Vic.) for acquisition of native title rights and interests. 	<ul style="list-style-type: none"> Director General, MTIA Chief Executive Officer, MRPV Director, Transport Property, DOT 	<p>To be exercised by the Director, Transport Property, DOT, unless this is not practicable.</p> <p>Before acquiring a native title right or interest in land in the project area, the delegate must give the Secretary particulars of the land and obtain the Secretary's approval in writing for the acquisition of that right or interest.</p>
Section 133	<p>The project authority may purchase land outside the project area for the purposes of an approved project, or preservation, restoration or provision of native habitat.</p>	<ul style="list-style-type: none"> Director General, MTIA Chief Executive Officer, MRPV Director, Transport Property, DOT <p>and the following class of positions:</p> <ul style="list-style-type: none"> Director, Delivery, MRPV 	<p>To be exercised by the Director, Transport Property, DOT, unless this is not practicable.</p> <p>Before purchasing any land outside the project area, the delegate must give the Secretary particulars of the land and obtain the Secretary's approval in writing for the purchase of that land.</p>
Section 137B	<p>The project authority may request the consent of the Project Minister to the surrender to the Crown of land held in fee simple if the land is intended to form part of a lease of land under section 177 of the MTPF Act.</p>	<ul style="list-style-type: none"> Director General, MTIA Chief Executive Officer, MRPV Director, Transport Property, DOT 	
Section 143	<p>The project authority must notify the Minister administering the Crown Land (Reserves) Act 1978 (Vic.) of reservation of land under Subdivision 1, 2 or 2A or Division 6 of the MTPF Act.</p>	<ul style="list-style-type: none"> Director General, MTIA Chief Executive Officer, MRPV Director, Transport Property, DOT 	

MTPF Act			
Column 1 MTPF Act Provision	Column 2 Summary of Provision	Column 3 Delegates	Column 4 Conditions or Limitations
Section 147	The project authority may transfer a building or structure from project land or project authority-owned land or Council-owned land, to other land owned by the Council as compensation.	<ul style="list-style-type: none"> • Director General, MTIA • Chief Executive Officer, MRPV • Director, Transport Property, DOT 	
Section 148	The project authority may require that adjoining land is provided as compensation to Council for land acquired compulsorily.	<ul style="list-style-type: none"> • Director General, MTIA • Chief Executive Officer, MRPV • Director, Transport Property, DOT 	
Section 151	The project authority may enter into possession of project land.	<ul style="list-style-type: none"> • Director General, MTIA • Chief Executive Officer, MRPV • Director, Transport Property, DOT <p>and the following class of positions:</p> <ul style="list-style-type: none"> • Director, Delivery, MRPV 	
Section 152	The project authority must diligently endeavour to obtain agreement with the occupier of project land on terms for entry into possession of the land.	<ul style="list-style-type: none"> • Director General, MTIA • Chief Executive Officer, MRPV • Director, Transport Property, DOT <p>and the following class of positions:</p> <ul style="list-style-type: none"> • Director, Delivery, MRPV • Program Director, MRPV • Project Director, MRPV 	
Section 155(1)	The project authority may enter an agreement in relation to the time of entry into possession of project land, with the consent of the Project Minister.	<ul style="list-style-type: none"> • Coordinator General, MTIA • Chief Executive Officer, MRPV • Director, Transport Property, DOT <p>and the following class of positions:</p> <ul style="list-style-type: none"> • Director, Delivery, MRPV • Program Director, MRPV • Project Director, MRPV 	

MTPF Act			
Column 1 MTPF Act Provision	Column 2 Summary of Provision	Column 3 Delegates	Column 4 Conditions or Limitations
Section 155(3)	The project authority must serve a copy of the certificate provided under section 155(1)(a) of the MTPF Act on the occupier.	<ul style="list-style-type: none"> • Director General, MTIA • Chief Executive Officer, MRPV • Director, Transport Property, DOT <p>and the following class of positions:</p> <ul style="list-style-type: none"> • Director, Delivery, MRPV • Program Director, MRPV • Project Director, MRPV 	
Section 156	The occupation period for project land may be extended by agreement between the project authority and the occupier of the project land.	<ul style="list-style-type: none"> • Director General, MTIA • Chief Executive Officer, MRPV • Director, Transport Property, DOT <p>and the following class of positions:</p> <ul style="list-style-type: none"> • Director, Delivery, MRPV • Program Director, MRPV • Project Director, MRPV 	
Section 158	Rent payable under the applicable Subdivision of the MTPF Act may be recovered as a debt due to the project authority in any court of competent jurisdiction.	<ul style="list-style-type: none"> • Director General, MTIA • Chief Executive Officer, MRPV • Director, Transport Property, DOT • Director, Commercial & Legal, MRPV 	
Section 159	The project authority may issue a warrant to the sheriff where entitled under the applicable Division to enter into possession of project land and an occupier of project land refuses to give up possession of the land or hinders entry to that land.	<ul style="list-style-type: none"> • Director General, MTIA • Chief Executive Officer, MRPV • Director, Commercial & Legal, MRPV 	

MTPF Act			
Column 1 MTPF Act Provision	Column 2 Summary of Provision	Column 3 Delegates	Column 4 Conditions or Limitations
Section 167	<p>The project authority:</p> <ul style="list-style-type: none"> • section 167(1): may carry out or authorise works on public land inside or outside the project area for the purposes of the approved project; and • section 167(2): must notify any Minister, public authority or Council that owns or manages the public land prior to works being carried out or performed. 	<ul style="list-style-type: none"> • Director General, MTIA • Chief Executive Officer, MRPV • Director, Commercial & Legal, MRPV <p>and the following class of positions:</p> <ul style="list-style-type: none"> • Director, Delivery, MRPV • Program Director, MRPV • Project Director, MRPV 	
Section 168A	<p>The project authority may carry out or authorise associated works where an applicable approval has been granted for those works or is not required.</p>	<ul style="list-style-type: none"> • Director General, MTIA • Chief Executive Officer, MRPV • Director, Commercial & Legal, MRPV <p>and the following class of positions:</p> <ul style="list-style-type: none"> • Director, Delivery, MRPV • Program Director, MRPV • Project Director, MRPV 	
Section 170	<p>The project authority may use or authorise use of any Crown land for the purposes of an approved project.</p>	<ul style="list-style-type: none"> • Director General, MTIA • Chief Executive Officer, MRPV • Director, Commercial & Legal, MRPV <p>and the following class of positions:</p> <ul style="list-style-type: none"> • Director, Delivery, MRPV • Program Director, MRPV • Project Director, MRPV 	

MTPF Act			
Column 1 MTPF Act Provision	Column 2 Summary of Provision	Column 3 Delegates	Column 4 Conditions or Limitations
Section 171	The project authority may carry out or authorise works on any land within an easement acquired under the applicable Part of the MTPF Act.	<ul style="list-style-type: none"> • Director General, MTIA • Chief Executive Officer, MRPV • Director, Commercial & Legal, MRPV <p>and the following class of positions:</p> <ul style="list-style-type: none"> • Director, Delivery, MRPV • Program Director, MRPV • Project Director, MRPV 	
Section 171A	The project authority may transfer to a utility any easement acquired over project land for the purposes of relocating utility infrastructure as a result of an approved project.	<ul style="list-style-type: none"> • Director General, MTIA • Chief Executive Officer, MRPV • Director, Transport Property, DOT • Director, Commercial & Legal, MRPV <p>and the following class of positions:</p> <ul style="list-style-type: none"> • Director, Delivery, MRPV • Program Director, MRPV • Project Director, MRPV 	
Section 173	The project authority may issue a licence to any person to enter and use all or any part of project land that is Crown land, or land that the project authority holds in fee simple, for the purposes of the approved project.	<ul style="list-style-type: none"> • Director General, MTIA • Chief Executive Officer, MRPV • Director, Transport Property, DOT <p>and the following class of positions:</p> <ul style="list-style-type: none"> • Director, Delivery, MRPV • Program Director, MRPV • Project Director, MRPV 	
Section 184	The project authority may enter into an agreement concerning the use or development of surplus land upon or in anticipation of disposing of the whole of its interest in the land.	<ul style="list-style-type: none"> • Director General, MTIA • Chief Executive Officer, MRPV • Director, Transport Property, DOT 	

MTPF Act			
Column 1 MTPF Act Provision	Column 2 Summary of Provision	Column 3 Delegates	Column 4 Conditions or Limitations
Section 185	The project authority may sell, lease or licence any surplus land held in fee simple.	<ul style="list-style-type: none"> • Director General, MTIA • Chief Executive Officer, MRPV • Director, Transport Property, DOT 	
Section 186	The project authority may: <ul style="list-style-type: none"> • open, discontinue, construct, relocate or realign roads, and close any road to traffic; • carry out improvements to roads in the project area; • construct roads over or under roads constructed or to be constructed in the project area; • construct any road in the project area over or under any other roads; and • cause fences, posts, or other structures to be erected along any road constructed or to be constructed in the project area, or across any entrance, approach or means of access to, any road constructed or to be constructed in the project area. 	<ul style="list-style-type: none"> • Director General, MTIA • Chief Executive Officer, MRPV • Director, Commercial & Legal, MRPV <p>and the following class of positions:</p> <ul style="list-style-type: none"> • Director, Delivery, MRPV • Program Director, MRPV • Project Director, MRPV 	
Section 187	The project authority must advise the coordinating road authority before exercising any power under section 186.	<ul style="list-style-type: none"> • Director General, MTIA • Chief Executive Officer, MRPV • Director, Commercial & Legal, MRPV <p>and the following class of positions:</p> <ul style="list-style-type: none"> • Director, Delivery, MRPV • Program Director, MRPV • Project Director, MRPV 	

MTPF Act			
Column 1 MTPF Act Provision	Column 2 Summary of Provision	Column 3 Delegates	Column 4 Conditions or Limitations
Section 189	The project authority must cause notice of a decision under section 186 to be published in the Government Gazette and in a newspaper being circulated throughout the area affected by the decision.	<ul style="list-style-type: none"> • Director General, MTIA • Chief Executive Officer, MRPV • Director, Commercial & Legal, MRPV <p>and the following class of positions:</p> <ul style="list-style-type: none"> • Director, Delivery, MRPV • Program Director, MRPV • Project Director, MRPV 	
Section 190	The project authority may temporarily close a road to traffic for the purposes of an approved project if considered necessary to do so for works on the road or neighbouring land to be carried out.	<ul style="list-style-type: none"> • Director General, MTIA • Chief Executive Officer, MRPV • Director, Commercial & Legal, MRPV <p>and the following class of positions:</p> <ul style="list-style-type: none"> • Director, Delivery, MRPV • Program Director, MRPV • Project Director, MRPV 	
Section 196	The project authority may establish or cause to be established as a 'restricted access area' a the project area or land temporarily occupied under section 75 of the Land Acquisition Compensation Act 1986 by use of fencing, barriers, other temporary or permanent means of physical demarcation or signage on or in proximity to the area.	<ul style="list-style-type: none"> • Director General, MTIA • Chief Executive Officer, MRPV • Director, Commercial & Legal, MRPV <p>and the following class of positions:</p> <ul style="list-style-type: none"> • Director, Delivery, MRPV • Program Director, MRPV • Project Director, MRPV 	

MTPF Act			
Column 1 MTPF Act Provision	Column 2 Summary of Provision	Column 3 Delegates	Column 4 Conditions or Limitations
Section 198	The project authority must issue identity cards to authorised officers appointed for the purposes of exercising functions in respect of restricted access areas.	<ul style="list-style-type: none"> • Director General, MTIA • Chief Executive Officer, MRPV • Director, Commercial & Legal, MRPV <p>and the following class of positions:</p> <ul style="list-style-type: none"> • Director, Delivery, MRPV • Program Director, MRPV • Project Director, MRPV 	
Section 199	The project authority may, by issuing a certificate or making a declaration, authorise a person or class of person to enter and remain in a restricted access area for the purposes of preparing or conducting activities for the purposes of an approved project or carrying out ancillary activities.	<ul style="list-style-type: none"> • Director General, MTIA • Chief Executive Officer, MRPV • Director, Commercial & Legal, MRPV <p>and the following class of positions:</p> <ul style="list-style-type: none"> • Director, Delivery, MRPV • Program Director, MRPV • Project Director, MRPV 	
Sections 200, 201	The project authority may warn any person (other than owner of land or a person authorised in writing by the owner or under the MTPF Act) to leave any part of the restricted access area under the applicable Division of the MTPF Act.	<ul style="list-style-type: none"> • Director General, MTIA • Chief Executive Officer, MRPV • Director, Commercial & Legal, MRPV <p>and the following class of positions:</p> <ul style="list-style-type: none"> • Director, Delivery, MRPV • Program Director, MRPV • Project Director, MRPV 	

MTPF Act			
Column 1 MTPF Act Provision	Column 2 Summary of Provision	Column 3 Delegates	Column 4 Conditions or Limitations
Sections 211, 211A	<p>The project authority:</p> <ul style="list-style-type: none"> • section 211: must take all reasonable steps to identify all utility infrastructure, and every utility that owns such infrastructure, that may be affected by the development of the declared project; and • section 211A: may give a notice to a utility identified under section 211 of the MTPF Act requiring it state whether it owns, operates or controls the relevant utility infrastructure in the specified area, describe the nature of that infrastructure and its location, and provide plans showing the location of that infrastructure. 	<ul style="list-style-type: none"> • Director General, MTIA • Chief Executive Officer, MRPV • Director, Commercial & Legal, MRPV <p>and the following class of positions:</p> <ul style="list-style-type: none"> • Director, Delivery, MRPV • Program Director, MRPV • Project Director, MRPV 	
Section 213	<p>Following the applicable notice period, the project authority may give written notice to a utility of an intention to commence negotiations with the utility for the purpose of entering a utility agreement.</p>	<ul style="list-style-type: none"> • Director General, MTIA • Chief Executive Officer, MRPV • Director, Commercial & Legal, MRPV <p>and the following class of positions:</p> <ul style="list-style-type: none"> • Director, Delivery, MRPV • Program Director, MRPV • Project Director, MRPV 	
Section 214	<p>The project authority (and the relevant utility) must use all reasonable endeavours to negotiate a utility agreement within 50 business days after notice is given under section 213 of the MTPF Act.</p>	<ul style="list-style-type: none"> • Director General, MTIA • Chief Executive Officer, MRPV • Director, Commercial & Legal, MRPV <p>and the following class of positions:</p> <ul style="list-style-type: none"> • Director, Delivery, MRPV • Program Director, MRPV • Project Director, MRPV 	

MTPF Act			
Column 1 MTPF Act Provision	Column 2 Summary of Provision	Column 3 Delegates	Column 4 Conditions or Limitations
Section 215	The project authority must give written notice to the Project Minister and Utility Minister for the utility if a utility agreement is not entered into between the parties within the applicable 50 business day period.	<ul style="list-style-type: none"> • Director General, MTIA • Chief Executive Officer, MRPV • Director, Commercial & Legal, MRPV <p>and the following class of positions:</p> <ul style="list-style-type: none"> • Director, Delivery, MRPV • Program Director, MRPV • Project Director, MRPV 	
Sections 216, 217, 218, 224, 225, 227	<p>The project authority may exercise the following project functions for dispute resolution and termination in relation to a utility agreement:</p> <ul style="list-style-type: none"> • section 216: give notice to the other party that a dispute exists; • section 217: use reasonable endeavours to agree on an expert for resolving the dispute; • section 218: inform the Project Minister if the parties have agreed on an expert to be appointed, or otherwise if there has been no such agreement; • section 224: provide a draft utility agreement that identifies the applicable matters in relation to which the parties do not agree; • section 225: make a submission to the expert in relation to the dispute; and • section 227: agree to termination or revocation of a utility agreement approved in accordance with section 226(4) of the MTPF Act. 	<ul style="list-style-type: none"> • Director General, MTIA • Chief Executive Officer, MRPV • Director, Commercial & Legal, MRPV <p>and the following class of positions:</p> <ul style="list-style-type: none"> • Director, Delivery, MRPV • Program Director, MRPV • Project Director, MRPV 	

MTPF Act			
Column 1 MTPF Act Provision	Column 2 Summary of Provision	Column 3 Delegates	Column 4 Conditions or Limitations
<p>Sections 232, 233, 234</p>	<p>The project authority may exercise the following project functions in relation to unnotified utility infrastructure:</p> <ul style="list-style-type: none"> • section 232: give written notice to utilities of the project authority's intention to remove, relocate or protect the infrastructure (as the case may be), and require the utility to agree to the relevant works or carry out the works itself; • section 233: if the project authority does not receive a response or the utility does not agree to the relevant works specified in a notice provided under section 232 of the MTPF Act, remove, relocate or carry out works in relation to utility infrastructure, and give the utility an estimate of costs for which the utility is liable for; and • section 234: notify the relevant utility of any damage caused to unnotified utility infrastructure, and undertake the applicable protection, relocation or removal activities in respect of utility infrastructure (including, if an emergency situation occurs, taking all reasonable steps to end the emergency). 	<ul style="list-style-type: none"> • Director General, MTIA • Chief Executive Officer, MRPV • Director, Commercial & Legal, MRPV <p>and the following class of positions:</p> <ul style="list-style-type: none"> • Director, Delivery, MRPV • Program Director, MRPV • Project Director, MRPV 	

LACA	Column 1 LACA Provision	Column 2 Summary of Provision	Column 3 Delegates	Column 4 Conditions or Limitations
Section 74 (as modified by section 118(5) of the MTPF Act)	<p>The project authority may, or may authorise another person to:</p> <ul style="list-style-type: none"> • enter and remain upon any land (with assistants, vehicles, machinery or equipment); • affix or establish any trigonometric stations, survey pegs, marks or poles; • undertake flora and fauna surveys, and archaeological investigations; and • dig or bore land, and take samples of soil, rock, ground water or minerals. 	<ul style="list-style-type: none"> • Director General, MTIA • Chief Executive Officer, MRPV • Director, Commercial & Legal, MRPV • Director, Transport Property, DOT <p>and the following class of positions:</p> <ul style="list-style-type: none"> • Director, Delivery, MRPV 	<p>To be exercised by the Director, Transport Property, DOT, unless this is not practicable.</p>	
Section 75 (as modified by section 119 of the MTPF Act)	<p>The project authority may, or may authorise another person to enter upon and occupy any land for the purposes:</p> <ul style="list-style-type: none"> • digging and taking from the land any clay, stone, gravel, earth or other substance; • depositing any material on the land; • making cuttings or excavations; • taking timber from the land; • making and using roads on the land; • manufacturing on the land any materials required; • demolishing structures (other than places of residence or business); • carrying out works on drainage channels, streams or other waterways, or works relating to the diversion of drainage channels, streams or other waterways; or • erecting temporary workshops, sheds and buildings. 	<ul style="list-style-type: none"> • Director General, MTIA • Chief Executive Officer, MRPV • Director, Commercial & Legal, MRPV • Director, Transport Property, DOT <p>and the following class of positions:</p> <ul style="list-style-type: none"> • Director, Delivery, MRPV 	<p>To be exercised by the Director, Transport Property, DOT, unless this is not practicable.</p>	

**Major Transport Projects Facilitation Act 2009, Transport Integration Act 2010 and
Land Acquisition and Compensation Act 1986**

INSTRUMENT OF DELEGATION BY SECRETARY

NARRE WARREN CRANBOURNE ROAD UPGRADE

I, Paul Younis, Secretary to the Department of Transport (**Secretary**) as project authority of the Narre Warren Cranbourne Upgrade project (**Project**), a declared project for which designation of the project area in accordance with Part 4 of the **Major Transport Projects Facilitation Act 2009** (Vic.) (**MTPF Act**) occurred on 27 March 2020, and as project authority being also:

- taken to be specified as a determining referral authority in the Casey Planning Scheme under the **Planning and Environment Act 1987** (Vic.) (**Planning and Environment Act 1987**) by operation of section 102A of the MTPF Act (**determining referral authority**); and
- the Authority for the purpose of the **Land Acquisition and Compensation Act 1986** (Vic.) (**LACA**) as applied by section 113 of the MTPF Act (**Authority**) –

in exercise of the powers vested in me under section 104 of the MTPF Act, section 39 of the **Transport Integration Act 2010** and any and all other enabling powers, hereby delegate to the person(s) from time to time employed within the Department of Transport (**DOT**) (which includes the Major Transport Infrastructure Authority, the administrative office existing in relation to DOT that is responsible for delivery of the Project (**MTIA**) and occupying the positions specified in Column 3 of the Schedule to this instrument (each a **Delegate**) such of:

- the project functions and powers conferred on me under the MTPF Act in respect of the Project;
- my powers, duties and functions as determining referral authority in relation to land in the project area; and
- my powers and functions as the Authority –

as are specified for the Delegate in Column 1 and summarised in Column 2 of the Schedule to this instrument, subject to the following conditions and limitations:

19. any condition or limitation that is specified in Column 4 of the Schedule to this instrument with respect to a power, duty or function that is specified in Column 1 of the Schedule to this instrument; and
20. the condition that the power, duty or function may only be exercised for the purpose of the Project.

If the Delegate considers that a project function is one that, in the particular circumstances, requires referral to the Secretary, then before exercising the project function the Delegate should inform and consult with the Secretary.

In the interpretation of this instrument, the summary of a provision set out in Column 2 of the Schedule to this instrument is for convenience only and, unless a contrary intention appears, does not amend, substitute or delete any part of a provision of the MTPF Act or LACA set out in Column 1 of the Schedule to this instrument or otherwise affect the scope or effect of the power, duty or function delegated.

A Delegate is not authorised to delegate or sub-delegate any power delegated under this instrument.

This delegation will remain valid until it is revoked.

The delegation I signed on 23 April 2020 delegating to persons employed within DOT certain powers, duties and functions in respect of the Project, is hereby revoked.

Dated 2 September 2020

PAUL YOUNIS
Secretary to the Department of Transport

SCHEDULE

MTPF Act			
Column 1 MTPF Act Provision	Column 2 Summary of Provision	Column 3 Delegates	Column 4 Conditions or Limitations
Section 96	The project authority may request the Planning Minister to vary the project area for the approved project.	<ul style="list-style-type: none"> • Director General, MTIA • Chief Executive Officer, Major Road Projects Victoria (MRPV) • Director, Commercial & Legal, MRPV 	
Section 101	<p>The project authority may exercise the project authority's functions, summarised as follows:</p> <ul style="list-style-type: none"> • section 101(a): facilitating development of the approved project; • sections 101(b), (c): evaluating submissions from and negotiating with interested parties; • sections 101(d), (e), (f): making recommendations in relation to, and entering and administering contractual arrangements for, development or delivery of the approved project; • sections 101(g), (h), (i): facilitating and coordinating consultations, and negotiating and entering into arrangements, and coordinating, with statutory authorities, agencies of the State and other bodies or persons involved in, or affected by, development or operation of the approved project; • section 101(i): making recommendations to the Project Minister in relation to facilitating the approved project; • section 101(j): ensuring that agreements and arrangements between the State and any other person for, or relating to, the development or delivery of the e approved project are performed in accordance with their terms; • section 101(k): commissioning transport infrastructure that is developed as part of the approved project; • section 101(l): undertaking any other functions conferred on the project authority under the MTPF Act or any other Act. 	<ul style="list-style-type: none"> • Director General, MTIA • Chief Executive Officer, MRPV • Director, Commercial & Legal, MRPV <p>and the following class of positions:</p> <ul style="list-style-type: none"> • Director, Delivery, MRPV 	

MTPF Act			
Column 1 MTPF Act Provision	Column 2 Summary of Provision	Column 3 Delegates	Column 4 Conditions or Limitations
Section 102	<p>For the purpose of performing its functions, and in addition to all other powers conferred on it by or under any other Act or law, exercising:</p> <ul style="list-style-type: none"> • section 102(1): a specified project power or power conferred on it by or under the MTPF Act; and • Section 102(2): do all other things necessary or convenient to be done for, or in connection with, or as incidental to, the performance of project functions under the MTPF Act. 	<ul style="list-style-type: none"> • Director General, MTIA • Chief Executive Officer, MRPV • Director, Commercial & Legal, MRPV • Director, Transport Property, DOT <p>and the following class of positions:</p> <ul style="list-style-type: none"> • Director, Delivery, MRPV 	
Section 102A	<p>The project authority for an approved project is taken to be specified as a determining referral authority in any planning scheme under the Planning and Environment Act.</p>	<ul style="list-style-type: none"> • Director General, MTIA • Chief Executive Officer, MRPV • Director, Commercial and Legal, MRPV <p>and the following class of positions:</p> <ul style="list-style-type: none"> • Director, Delivery, MRPV • Program Director, MRPV • Project Director, MRPV 	
Section 110	<p>On completion of an approved project, the project authority must notify the Project Minister of the project's completion.</p>	<ul style="list-style-type: none"> • Director General, MTIA • Chief Executive Officer, MRPV 	
Section 112	<p>The project authority may acquire an interest in land in the project area by agreement or by a compulsory process for the purposes of an approved project or any purpose connected with the approved project.</p>	<ul style="list-style-type: none"> • Director, Transport Property, DOT • Director General, MTIA • Chief Executive Officer, MRPV <p>and the following class of positions:</p> <ul style="list-style-type: none"> • Director, Delivery, MRPV 	<p>To be exercised by the Director, Transport Property, DOT, unless this is not practicable.</p> <p>Before acquiring an interest in any land, the delegate must give the Secretary particulars of the land and obtain the Secretary's approval in writing for the acquisition of that land.</p>

MTPF Act			
Column 1 MTPF Act Provision	Column 2 Summary of Provision	Column 3 Delegates	Column 4 Conditions or Limitations
Section 120(4), 120(5)	<p>The project authority must:</p> <ul style="list-style-type: none"> • section 120(4): make an offer for the payment of rent to the owner of the land for the authority's occupation of that land; and • section 120(5): if an amount of rent to be paid is not agreed upon, notify the Valuer-General in writing of any disagreement with an owner of land as to the amount of rent to be paid. 	<ul style="list-style-type: none"> • Director General, MTIA • Chief Executive Officer, MRPV • Director, Transport Property, DOT <p>and the following class of positions:</p> <ul style="list-style-type: none"> • Director, Delivery, MRPV 	
Section 121	<p>The project authority must:</p> <ul style="list-style-type: none"> • give the owner of land a condition report; • negotiate the contents of the condition report should the owner disagree; and • failing which, notify the Valuer General of a dispute under this section. 	<ul style="list-style-type: none"> • Director General, MTIA • Chief Executive Officer, MRPV • Director, Transport Property, DOT <p>and the following class of positions:</p> <ul style="list-style-type: none"> • Director, Delivery, MRPV • Program Director, MRPV • Project Director, MRPV 	
Section 123	<p>A project authority may transfer a building or structure in full or in part settlement of any compensation that the project authority is liable to pay.</p>	<ul style="list-style-type: none"> • Director General, MTIA • Chief Executive Officer, MRPV • Director, Transport Property, DOT 	
Section 124	<p>If a project authority acquires compulsorily under Division 1 of Part 6 to the MTPF Act part of a parcel of land owned by a person, the project authority may require that person to take as compensation land that adjoins the part of the parcel that was not acquired; and that is owned by the project authority or is surplus land.</p>	<ul style="list-style-type: none"> • Director General, MTIA • Chief Executive Officer, MRPV • Director, Transport Property, DOT 	

MTPF Act			
Column 1 MTPF Act Provision	Column 2 Summary of Provision	Column 3 Delegates	Column 4 Conditions or Limitations
Sections 127, 129	<p>The project authority is authorised to:</p> <ul style="list-style-type: none"> section 127: compulsorily acquire a native title right or interest in land in the project area for the purposes of an approved project or any purpose connected with an approved project; section 129: comply with relevant procedures under the Native Title Act 1993 (Vic.) for acquisition of native title rights and interests. 	<ul style="list-style-type: none"> Director General, MTIA Chief Executive Officer, MRPV Director, Transport Property, DOT 	<p>To be exercised by the Director, Transport Property, DOT, unless this is not practicable.</p> <p>Before acquiring a native title right or interest in land in the project area, the delegate must give the Secretary particulars of the land and obtain the Secretary's approval in writing for the acquisition of that right or interest.</p>
Section 133	<p>The project authority may purchase land outside the project area for the purposes of an approved project, or preservation, restoration or provision of native habitat.</p>	<ul style="list-style-type: none"> Director General, MTIA Chief Executive Officer, MRPV Director, Transport Property, DOT <p>and the following class of positions:</p> <ul style="list-style-type: none"> Director, Delivery, MRPV 	<p>To be exercised by the Director, Transport Property, DOT, unless this is not practicable.</p> <p>Before purchasing any land outside the project area, the delegate must give the Secretary particulars of the land and obtain the Secretary's approval in writing for the purchase of that land.</p>
Section 137B	<p>The project authority may request the consent of the Project Minister to the surrender to the Crown of land held in fee simple if the land is intended to form part of a lease of land under section 177 of the MTPF Act.</p>	<ul style="list-style-type: none"> Director General, MTIA Chief Executive Officer, MRPV Director, Transport Property, DOT 	
Section 143	<p>The project authority must notify the Minister administering the Crown Land (Reserves) Act 1978 (Vic.) of reservation of land under Subdivision 1, 2 or 2A or Division 6 of the MTPF Act.</p>	<ul style="list-style-type: none"> Director General, MTIA Chief Executive Officer, MRPV Director, Transport Property, DOT 	

MTPF Act			
Column 1 MTPF Act Provision	Column 2 Summary of Provision	Column 3 Delegates	Column 4 Conditions or Limitations
Section 147	The project authority may transfer a building or structure from project land or project authority-owned land or Council-owned land, to other land owned by the Council as compensation.	<ul style="list-style-type: none"> • Director General, MTIA • Chief Executive Officer, MRPV • Director, Transport Property, DOT 	
Section 148	The project authority may require that adjoining land is provided as compensation to Council for land acquired compulsorily.	<ul style="list-style-type: none"> • Director General, MTIA • Chief Executive Officer, MRPV • Director, Transport Property, DOT 	
Section 151	The project authority may enter into possession of project land.	<ul style="list-style-type: none"> • Director General, MTIA • Chief Executive Officer, MRPV • Director, Transport Property, DOT <p>and the following class of positions:</p> <ul style="list-style-type: none"> • Director, Delivery, MRPV 	
Section 152	The project authority must diligently endeavour to obtain agreement with the occupier of project land on terms for entry into possession of the land.	<ul style="list-style-type: none"> • Director General, MTIA • Chief Executive Officer, MRPV • Director, Transport Property, DOT <p>and the following class of positions:</p> <ul style="list-style-type: none"> • Director, Delivery, MRPV • Program Director, MRPV • Project Director, MRPV 	
Section 155(1)	The project authority may enter an agreement in relation to the time of entry into possession of project land, with the consent of the Project Minister.	<ul style="list-style-type: none"> • Coordinator General, MTIA • Chief Executive Officer, MRPV • Director, Transport Property, DOT <p>and the following class of positions:</p> <ul style="list-style-type: none"> • Director, Delivery, MRPV • Program Director, MRPV • Project Director, MRPV 	

MTPF Act			
Column 1 MTPF Act Provision	Column 2 Summary of Provision	Column 3 Delegates	Column 4 Conditions or Limitations
Section 155(3)	The project authority must serve a copy of the certificate provided under section 155(1)(a) of the MTPF Act on the occupier.	<ul style="list-style-type: none"> • Director General, MTIA • Chief Executive Officer, MRPV • Director, Transport Property, DOT <p>and the following class of positions:</p> <ul style="list-style-type: none"> • Director, Delivery, MRPV • Program Director, MRPV • Project Director, MRPV 	
Section 156	The occupation period for project land may be extended by agreement between the project authority and the occupier of the project land.	<ul style="list-style-type: none"> • Director General, MTIA • Chief Executive Officer, MRPV • Director, Transport Property, DOT <p>and the following class of positions:</p> <ul style="list-style-type: none"> • Director, Delivery, MRPV • Program Director, MRPV • Project Director, MRPV 	
Section 158	Rent payable under the applicable Subdivision of the MTPF Act may be recovered as a debt due to the project authority in any court of competent jurisdiction.	<ul style="list-style-type: none"> • Director General, MTIA • Chief Executive Officer, MRPV • Director, Transport Property, DOT • Director, Commercial & Legal, MRPV 	
Section 159	The project authority may issue a warrant to the sheriff where entitled under the applicable Division to enter into possession of project land and an occupier of project land refuses to give up possession of the land or hinders entry to that land.	<ul style="list-style-type: none"> • Director General, MTIA • Chief Executive Officer, MRPV • Director, Commercial & Legal, MRPV 	

MTPF Act			
Column 1 MTPF Act Provision	Column 2 Summary of Provision	Column 3 Delegates	Column 4 Conditions or Limitations
Section 167	<p>The project authority:</p> <ul style="list-style-type: none"> • section 167(1): may carry out or authorise works on public land inside or outside the project area for the purposes of the approved project; and • section 167(2): must notify any Minister, public authority or Council that owns or manages the public land prior to works being carried out or performed. 	<ul style="list-style-type: none"> • Director General, MTIA • Chief Executive Officer, MRPV • Director, Commercial & Legal, MRPV <p>and the following class of positions:</p> <ul style="list-style-type: none"> • Director, Delivery, MRPV • Program Director, MRPV • Project Director, MRPV 	
Section 168A	<p>The project authority may carry out or authorise associated works where an applicable approval has been granted for those works or is not required.</p>	<ul style="list-style-type: none"> • Director General, MTIA • Chief Executive Officer, MRPV • Director, Commercial & Legal, MRPV <p>and the following class of positions:</p> <ul style="list-style-type: none"> • Director, Delivery, MRPV • Program Director, MRPV • Project Director, MRPV 	
Section 170	<p>The project authority may use or authorise use of any Crown land for the purposes of an approved project.</p>	<ul style="list-style-type: none"> • Director General, MTIA • Chief Executive Officer, MRPV • Director, Commercial & Legal, MRPV <p>and the following class of positions:</p> <ul style="list-style-type: none"> • Director, Delivery, MRPV • Program Director, MRPV • Project Director, MRPV 	

MTPF Act			
Column 1 MTPF Act Provision	Column 2 Summary of Provision	Column 3 Delegates	Column 4 Conditions or Limitations
Section 171	The project authority may carry out or authorise works on any land within an easement acquired under the applicable Part of the MTPF Act.	<ul style="list-style-type: none"> • Director General, MTIA • Chief Executive Officer, MRPV • Director, Commercial & Legal, MRPV <p>and the following class of positions:</p> <ul style="list-style-type: none"> • Director, Delivery, MRPV • Program Director, MRPV • Project Director, MRPV 	
Section 171A	The project authority may transfer to a utility any easement acquired over project land for the purposes of relocating utility infrastructure as a result of an approved project.	<ul style="list-style-type: none"> • Director General, MTIA • Chief Executive Officer, MRPV • Director, Transport Property, DOT • Director, Commercial & Legal, MRPV <p>and the following class of positions:</p> <ul style="list-style-type: none"> • Director, Delivery, MRPV • Program Director, MRPV • Project Director, MRPV 	
Section 173	The project authority may issue a licence to any person to enter and use all or any part of project land that is Crown land, or land that the project authority holds in fee simple, for the purposes of the approved project.	<ul style="list-style-type: none"> • Director General, MTIA • Chief Executive Officer, MRPV • Director, Transport Property, DOT <p>and the following class of positions:</p> <ul style="list-style-type: none"> • Director, Delivery, MRPV • Program Director, MRPV • Project Director, MRPV 	
Section 184	The project authority may enter into an agreement concerning the use or development of surplus land upon or in anticipation of disposing of the whole of its interest in the land.	<ul style="list-style-type: none"> • Director General, MTIA • Chief Executive Officer, MRPV • Director, Transport Property, DOT 	

MTPF Act			
Column 1 MTPF Act Provision	Column 2 Summary of Provision	Column 3 Delegates	Column 4 Conditions or Limitations
Section 185	The project authority may sell, lease or licence any surplus land held in fee simple.	<ul style="list-style-type: none"> • Director General, MTIA • Chief Executive Officer, MRPV • Director, Transport Property, DOT 	
Section 186	<p>The project authority may:</p> <ul style="list-style-type: none"> • open, discontinue, construct, relocate or realign roads, and close any road to traffic; • carry out improvements to roads in the project area; • construct roads over or under roads constructed or to be constructed in the project area; • construct any road in the project area over or under any other roads; and • cause fences, posts, or other structures to be erected along any road constructed or to be constructed in the project area, or across any entrance, approach or means of access to, any road constructed or to be constructed in the project area. 	<ul style="list-style-type: none"> • Director General, MTIA • Chief Executive Officer, MRPV • Director, Commercial & Legal, MRPV <p>and the following class of positions:</p> <ul style="list-style-type: none"> • Director, Delivery, MRPV • Program Director, MRPV • Project Director, MRPV 	
Section 187	The project authority must advise the coordinating road authority before exercising any power under section 186.	<ul style="list-style-type: none"> • Director General, MTIA • Chief Executive Officer, MRPV • Director, Commercial & Legal, MRPV <p>and the following class of positions:</p> <ul style="list-style-type: none"> • Director, Delivery, MRPV • Program Director, MRPV • Project Director, MRPV 	

MTPF Act			
Column 1 MTPF Act Provision	Column 2 Summary of Provision	Column 3 Delegates	Column 4 Conditions or Limitations
Section 189	The project authority must cause notice of a decision under section 186 to be published in the Government Gazette and in a newspaper being circulated throughout the area affected by the decision.	<ul style="list-style-type: none"> • Director General, MTIA • Chief Executive Officer, MRPV • Director, Commercial & Legal, MRPV <p>and the following class of positions:</p> <ul style="list-style-type: none"> • Director, Delivery, MRPV • Program Director, MRPV • Project Director, MRPV 	
Section 190	The project authority may temporarily close a road to traffic for the purposes of an approved project if considered necessary to do so for works on the road or neighbouring land to be carried out.	<ul style="list-style-type: none"> • Director General, MTIA • Chief Executive Officer, MRPV • Director, Commercial & Legal, MRPV <p>and the following class of positions:</p> <ul style="list-style-type: none"> • Director, Delivery, MRPV • Program Director, MRPV • Project Director, MRPV 	
Section 196	The project authority may establish or cause to be established as a 'restricted access area' a the project area or land temporarily occupied under section 75 of the Land Acquisition Compensation Act 1986 by use of fencing, barriers, other temporary or permanent means of physical demarcation or signage on or in proximity to the area.	<ul style="list-style-type: none"> • Director General, MTIA • Chief Executive Officer, MRPV • Director, Commercial & Legal, MRPV <p>and the following class of positions:</p> <ul style="list-style-type: none"> • Director, Delivery, MRPV • Program Director, MRPV • Project Director, MRPV 	

MTPF Act			
Column 1 MTPF Act Provision	Column 2 Summary of Provision	Column 3 Delegates	Column 4 Conditions or Limitations
Section 198	The project authority must issue identity cards to authorised officers appointed for the purposes of exercising functions in respect of restricted access areas.	<ul style="list-style-type: none"> • Director General, MTIA • Chief Executive Officer, MRPV • Director, Commercial & Legal, MRPV <p>and the following class of positions:</p> <ul style="list-style-type: none"> • Director, Delivery, MRPV • Program Director, MRPV • Project Director, MRPV 	
Section 199	The project authority may, by issuing a certificate or making a declaration, authorise a person or class of person to enter and remain in a restricted access area for the purposes of preparing or conducting activities for the purposes of an approved project or carrying out ancillary activities.	<ul style="list-style-type: none"> • Director General, MTIA • Chief Executive Officer, MRPV • Director, Commercial & Legal, MRPV <p>and the following class of positions:</p> <ul style="list-style-type: none"> • Director, Delivery, MRPV • Program Director, MRPV • Project Director, MRPV 	
Sections 200, 201	The project authority may warn any person (other than owner of land or a person authorised in writing by the owner or under the MTPF Act) to leave any part of the restricted access area under the applicable Division of the MTPF Act.	<ul style="list-style-type: none"> • Director General, MTIA • Chief Executive Officer, MRPV • Director, Commercial & Legal, MRPV <p>and the following class of positions:</p> <ul style="list-style-type: none"> • Director, Delivery, MRPV • Program Director, MRPV • Project Director, MRPV 	

MTPF Act			
Column 1 MTPF Act Provision	Column 2 Summary of Provision	Column 3 Delegates	Column 4 Conditions or Limitations
Sections 211, 211A	<p>The project authority:</p> <ul style="list-style-type: none"> • section 211: must take all reasonable steps to identify all utility infrastructure, and every utility that owns such infrastructure, that may be affected by the development of the declared project; and • section 211A: may give a notice to a utility identified under section 211 of the MTPF Act requiring it state whether it owns, operates or controls the relevant utility infrastructure in the specified area, describe the nature of that infrastructure and its location, and provide plans showing the location of that infrastructure. 	<ul style="list-style-type: none"> • Director General, MTIA • Chief Executive Officer, MRPV • Director, Commercial & Legal, MRPV <p>and the following class of positions:</p> <ul style="list-style-type: none"> • Director, Delivery, MRPV • Program Director, MRPV • Project Director, MRPV 	
Section 213	<p>Following the applicable notice period, the project authority may give written notice to a utility of an intention to commence negotiations with the utility for the purpose of entering a utility agreement.</p>	<ul style="list-style-type: none"> • Director General, MTIA • Chief Executive Officer, MRPV • Director, Commercial & Legal, MRPV <p>and the following class of positions:</p> <ul style="list-style-type: none"> • Director, Delivery, MRPV • Program Director, MRPV • Project Director, MRPV 	
Section 214	<p>The project authority (and the relevant utility) must use all reasonable endeavours to negotiate a utility agreement within 50 business days after notice is given under section 213 of the MTPF Act.</p>	<ul style="list-style-type: none"> • Director General, MTIA • Chief Executive Officer, MRPV • Director, Commercial & Legal, MRPV <p>and the following class of positions:</p> <ul style="list-style-type: none"> • Director, Delivery, MRPV • Program Director, MRPV • Project Director, MRPV 	

MTPF Act			
Column 1 MTPF Act Provision	Column 2 Summary of Provision	Column 3 Delegates	Column 4 Conditions or Limitations
Section 215	The project authority must give written notice to the Project Minister and Utility Minister for the utility if a utility agreement is not entered into between the parties within the applicable 50 business day period.	<ul style="list-style-type: none"> • Director General, MTIA • Chief Executive Officer, MRPV • Director, Commercial & Legal, MRPV <p>and the following class of positions:</p> <ul style="list-style-type: none"> • Director, Delivery, MRPV • Program Director, MRPV • Project Director, MRPV 	
Sections 216, 217, 218, 224, 225, 227	<p>The project authority may exercise the following project functions for dispute resolution and termination in relation to a utility agreement:</p> <ul style="list-style-type: none"> • section 216: give notice to the other party that a dispute exists; • section 217: use reasonable endeavours to agree on an expert for resolving the dispute; • section 218: inform the Project Minister if the parties have agreed on an expert to be appointed, or otherwise if there has been no such agreement; • section 224: provide a draft utility agreement that identifies the applicable matters in relation to which the parties do not agree; • section 225: make a submission to the expert in relation to the dispute; and • section 227: agree to termination or revocation of a utility agreement approved in accordance with section 226(4) of the MTPF Act. 	<ul style="list-style-type: none"> • Director General, MTIA • Chief Executive Officer, MRPV • Director, Commercial & Legal, MRPV <p>and the following class of positions:</p> <ul style="list-style-type: none"> • Director, Delivery, MRPV • Program Director, MRPV • Project Director, MRPV 	

MTPF Act			
Column 1 MTPF Act Provision	Column 2 Summary of Provision	Column 3 Delegates	Column 4 Conditions or Limitations
Sections 232, 233, 234	<p>The project authority may exercise the following project functions in relation to unnotified utility infrastructure:</p> <ul style="list-style-type: none"> • section 232: give written notice to utilities of the project authority's intention to remove, relocate or protect the infrastructure (as the case may be), and require the utility to agree to the relevant works or carry out the works itself; • section 233: if the project authority does not receive a response or the utility does not agree to the relevant works specified in a notice provided under section 232 of the MTPF Act, remove, relocate or carry out works in relation to utility infrastructure, and give the utility an estimate of costs for which the utility is liable for; and • section 234: notify the relevant utility of any damage caused to unnotified utility infrastructure, and undertake the applicable protection, relocation or removal activities in respect of utility infrastructure (including, if an emergency situation occurs, taking all reasonable steps to end the emergency). 	<ul style="list-style-type: none"> • Director General, MTIA • Chief Executive Officer, MRPV • Director, Commercial & Legal, MRPV <p>and the following class of positions:</p> <ul style="list-style-type: none"> • Director, Delivery, MRPV • Program Director, MRPV • Project Director, MRPV 	

LACA	Column 1 LACA Provision	Column 2 Summary of Provision	Column 3 Delegates	Column 4 Conditions or Limitations
Section 74 (as modified by section 118(5) of the MTPF Act)	<p>The project authority may, or may authorise another person to:</p> <ul style="list-style-type: none"> • enter and remain upon any land (with assistants, vehicles, machinery or equipment); • affix or establish any trigonometric stations, survey pegs, marks or poles; • undertake flora and fauna surveys, and archaeological investigations; and • dig or bore land, and take samples of soil, rock, ground water or minerals. 	<ul style="list-style-type: none"> • Director General, MTIA • Chief Executive Officer, MRPV • Director, Commercial & Legal, MRPV • Director, Transport Property, DOT <p>and the following class of positions:</p> <ul style="list-style-type: none"> • Director, Delivery, MRPV 	<p>To be exercised by the Director, Transport Property, DOT, unless this is not practicable.</p>	
Section 75 (as modified by section 119 of the MTPF Act)	<p>The project authority may, or may authorise another person to enter upon and occupy any land for the purposes:</p> <ul style="list-style-type: none"> • digging and taking from the land any clay, stone, gravel, earth or other substance; • depositing any material on the land; • making cuttings or excavations; • taking timber from the land; • making and using roads on the land; • manufacturing on the land any materials required; • demolishing structures (other than places of residence or business); • carrying out works on drainage channels, streams or other waterways, or works relating to the diversion of drainage channels, streams or other waterways; or • erecting temporary workshops, sheds and buildings. 	<ul style="list-style-type: none"> • Director General, MTIA • Chief Executive Officer, MRPV • Director, Commercial & Legal, MRPV • Director, Transport Property, DOT <p>and the following class of positions:</p> <ul style="list-style-type: none"> • Director, Delivery, MRPV 	<p>To be exercised by the Director, Transport Property, DOT, unless this is not practicable.</p>	

**Major Transport Projects Facilitation Act 2009, Transport Integration Act 2010 and
Land Acquisition and Compensation Act 1986**

INSTRUMENT OF DELEGATION BY SECRETARY

POUND ROAD WEST UPGRADE

I, Paul Younis, Secretary to the Department of Transport (**Secretary**) as project authority of the Pound Road West Upgrade project (**Project**), a declared project for which designation of the project area in accordance with Part 4 of the **Major Transport Projects Facilitation Act 2009** (*Vic.*) (**MTPF Act**) occurred on 27 March 2020, and as project authority being also:

- taken to be specified as a determining referral authority in the Greater Dandenong Planning Scheme under the **Planning and Environment Act 1987** (*Vic.*) (**Planning and Environment Act 1987**) by operation of section 102A of the MTPF Act (**determining referral authority**); and
- the Authority for the purpose of the **Land Acquisition and Compensation Act 1986** (*Vic.*) (**LACA**) as applied by section 113 of the MTPF Act (**Authority**) –

in exercise of the powers vested in me under section 104 of the MTPF Act, section 39 of the **Transport Integration Act 2010** and any and all other enabling powers, hereby delegate to the person(s) from time to time employed within the Department of Transport (**DOT**) (which includes the Major Transport Infrastructure Authority, the administrative office existing in relation to DOT that is responsible for delivery of the Project (**MTIA**) and occupying the positions specified in Column 3 of the Schedule to this instrument (each a **Delegate**) such of:

- the project functions and powers conferred on me under the MTPF Act in respect of the Project;
- my powers, duties and functions as determining referral authority in relation to land in the project area; and
- my powers and functions as the Authority –

as are specified for the Delegate in Column 1 and summarised in Column 2 of the Schedule to this instrument, subject to the following conditions and limitations:

21. any condition or limitation that is specified in Column 4 of the Schedule to this instrument with respect to a power, duty or function that is specified in Column 1 of the Schedule to this instrument; and
22. the condition that the power, duty or function may only be exercised for the purpose of the Project.

If the Delegate considers that a project function is one that, in the particular circumstances, requires referral to the Secretary, then before exercising the project function the Delegate should inform and consult with the Secretary.

In the interpretation of this instrument, the summary of a provision set out in Column 2 of the Schedule to this instrument is for convenience only and, unless a contrary intention appears, does not amend, substitute or delete any part of a provision of the MTPF Act or LACA set out in Column 1 of the Schedule to this instrument or otherwise affect the scope or effect of the power, duty or function delegated.

A Delegate is not authorised to delegate or sub-delegate any power delegated under this instrument.

This delegation will remain valid until it is revoked.

The delegation I signed on 23 April 2020 delegating to persons employed within DOT certain powers, duties and functions in respect of the Project, is hereby revoked.

Dated 2 September 2020

PAUL YOUNIS
Secretary to the Department of Transport

SCHEDULE

MTPF Act			
Column 1 MTPF Act Provision	Column 2 Summary of Provision	Column 3 Delegates	Column 4 Conditions or Limitations
Section 96	The project authority may request the Planning Minister to vary the project area for the approved project.	<ul style="list-style-type: none"> • Director General, MTIA • Chief Executive Officer, Major Road Projects Victoria (MRPV) • Director, Commercial & Legal, MRPV 	
Section 101	<p>The project authority may exercise the project authority's functions, summarised as follows:</p> <ul style="list-style-type: none"> • section 101(a): facilitating development of the approved project; • sections 101(b), (c): evaluating submissions from and negotiating with interested parties; • sections 101(d), (e), (f): making recommendations in relation to, and entering and administering contractual arrangements for, development or delivery of the approved project; • sections 101(g), (h), (i): facilitating and coordinating consultations, and negotiating and entering into arrangements, and coordinating, with statutory authorities, agencies of the State and other bodies or persons involved in, or affected by, development or operation of the approved project; • section 101(i): making recommendations to the Project Minister in relation to facilitating the approved project; • section 101(j): ensuring that agreements and arrangements between the State and any other person for, or relating to, the development or delivery of the e approved project are performed in accordance with their terms; • section 101(k): commissioning transport infrastructure that is developed as part of the approved project; • section 101(l): undertaking any other functions conferred on the project authority under the MTPF Act or any other Act. 	<ul style="list-style-type: none"> • Director General, MTIA • Chief Executive Officer, MRPV • Director, Commercial & Legal, MRPV <p>and the following class of positions:</p> <ul style="list-style-type: none"> • Director, Delivery, MRPV 	

MTPF Act			
Column 1 MTPF Act Provision	Column 2 Summary of Provision	Column 3 Delegates	Column 4 Conditions or Limitations
Section 102	<p>For the purpose of performing its functions, and in addition to all other powers conferred on it by or under any other Act or law, exercising:</p> <ul style="list-style-type: none"> • section 102(1): a specified project power or power conferred on it by or under the MTPF Act; and • Section 102(2): do all other things necessary or convenient to be done for, or in connection with, or as incidental to, the performance of project functions under the MTPF Act. 	<ul style="list-style-type: none"> • Director General, MTIA • Chief Executive Officer, MRPV • Director, Commercial & Legal, MRPV • Director, Transport Property, DOT <p>and the following class of positions:</p> <ul style="list-style-type: none"> • Director, Delivery, MRPV 	
Section 102A	<p>The project authority for an approved project is taken to be specified as a determining referral authority in any planning scheme under the Planning and Environment Act.</p>	<ul style="list-style-type: none"> • Director General, MTIA • Chief Executive Officer, MRPV • Director, Commercial and Legal, MRPV <p>and the following class of positions:</p> <ul style="list-style-type: none"> • Director, Delivery, MRPV • Program Director, MRPV • Project Director, MRPV 	
Section 110	<p>On completion of an approved project, the project authority must notify the Project Minister of the project's completion.</p>	<ul style="list-style-type: none"> • Director General, MTIA • Chief Executive Officer, MRPV 	
Section 112	<p>The project authority may acquire an interest in land in the project area by agreement or by a compulsory process for the purposes of an approved project or any purpose connected with the approved project.</p>	<ul style="list-style-type: none"> • Director, Transport Property, DOT • Director General, MTIA • Chief Executive Officer, MRPV <p>and the following class of positions:</p> <ul style="list-style-type: none"> • Director, Delivery, MRPV 	<p>To be exercised by the Director, Transport Property, DOT, unless this is not practicable.</p> <p>Before acquiring an interest in any land, the delegate must give the Secretary particulars of the land and obtain the Secretary's approval in writing for the acquisition of that land.</p>

MTPF Act			
Column 1 MTPF Act Provision	Column 2 Summary of Provision	Column 3 Delegates	Column 4 Conditions or Limitations
Section 120(4), 120(5)	<p>The project authority must:</p> <ul style="list-style-type: none"> • section 120(4): make an offer for the payment of rent to the owner of the land for the authority's occupation of that land; and • section 120(5): if an amount of rent to be paid is not agreed upon, notify the Valuer-General in writing of any disagreement with an owner of land as to the amount of rent to be paid. 	<ul style="list-style-type: none"> • Director General, MTIA • Chief Executive Officer, MRPV • Director, Transport Property, DOT <p>and the following class of positions:</p> <ul style="list-style-type: none"> • Director, Delivery, MRPV 	
Section 121	<p>The project authority must:</p> <ul style="list-style-type: none"> • give the owner of land a condition report; • negotiate the contents of the condition report should the owner disagree; and • failing which, notify the Valuer General of a dispute under this section. 	<ul style="list-style-type: none"> • Director General, MTIA • Chief Executive Officer, MRPV • Director, Transport Property, DOT <p>and the following class of positions:</p> <ul style="list-style-type: none"> • Director, Delivery, MRPV • Program Director, MRPV • Project Director, MRPV 	
Section 123	<p>A project authority may transfer a building or structure in full or in part settlement of any compensation that the project authority is liable to pay.</p>	<ul style="list-style-type: none"> • Director General, MTIA • Chief Executive Officer, MRPV • Director, Transport Property, DOT 	
Section 124	<p>If a project authority acquires compulsorily under Division 1 of Part 6 to the MTPF Act part of a parcel of land owned by a person, the project authority may require that person to take as compensation land that adjoins the part of the parcel that was not acquired; and that is owned by the project authority or is surplus land.</p>	<ul style="list-style-type: none"> • Director General, MTIA • Chief Executive Officer, MRPV • Director, Transport Property, DOT 	

MTPF Act			
Column 1 MTPF Act Provision	Column 2 Summary of Provision	Column 3 Delegates	Column 4 Conditions or Limitations
Sections 127, 129	<p>The project authority is authorised to:</p> <ul style="list-style-type: none"> section 127: compulsorily acquire a native title right or interest in land in the project area for the purposes of an approved project or any purpose connected with an approved project; section 129: comply with relevant procedures under the Native Title Act 1993 (Vic.) for acquisition of native title rights and interests. 	<ul style="list-style-type: none"> Director General, MTIA Chief Executive Officer, MRPV Director, Transport Property, DOT 	<p>To be exercised by the Director, Transport Property, DOT, unless this is not practicable.</p> <p>Before acquiring a native title right or interest in land in the project area, the delegate must give the Secretary particulars of the land and obtain the Secretary's approval in writing for the acquisition of that right or interest.</p>
Section 133	<p>The project authority may purchase land outside the project area for the purposes of an approved project, or preservation, restoration or provision of native habitat.</p>	<ul style="list-style-type: none"> Director General, MTIA Chief Executive Officer, MRPV Director, Transport Property, DOT <p>and the following class of positions:</p> <ul style="list-style-type: none"> Director, Delivery, MRPV 	<p>To be exercised by the Director, Transport Property, DOT, unless this is not practicable.</p> <p>Before purchasing any land outside the project area, the delegate must give the Secretary particulars of the land and obtain the Secretary's approval in writing for the purchase of that land.</p>
Section 137B	<p>The project authority may request the consent of the Project Minister to the surrender to the Crown of land held in fee simple if the land is intended to form part of a lease of land under section 177 of the MTPF Act.</p>	<ul style="list-style-type: none"> Director General, MTIA Chief Executive Officer, MRPV Director, Transport Property, DOT 	
Section 143	<p>The project authority must notify the Minister administering the Crown Land (Reserves) Act 1978 (Vic.) of reservation of land under Subdivision 1, 2 or 2A or Division 6 of the MTPF Act.</p>	<ul style="list-style-type: none"> Director General, MTIA Chief Executive Officer, MRPV Director, Transport Property, DOT 	

MTPF Act			
Column 1 MTPF Act Provision	Column 2 Summary of Provision	Column 3 Delegates	Column 4 Conditions or Limitations
Section 147	The project authority may transfer a building or structure from project land or project authority-owned land or Council-owned land, to other land owned by the Council as compensation.	<ul style="list-style-type: none"> • Director General, MTIA • Chief Executive Officer, MRPV • Director, Transport Property, DOT 	
Section 148	The project authority may require that adjoining land is provided as compensation to Council for land acquired compulsorily.	<ul style="list-style-type: none"> • Director General, MTIA • Chief Executive Officer, MRPV • Director, Transport Property, DOT 	
Section 151	The project authority may enter into possession of project land.	<ul style="list-style-type: none"> • Director General, MTIA • Chief Executive Officer, MRPV • Director, Transport Property, DOT <p>and the following class of positions:</p> <ul style="list-style-type: none"> • Director, Delivery, MRPV 	
Section 152	The project authority must diligently endeavour to obtain agreement with the occupier of project land on terms for entry into possession of the land.	<ul style="list-style-type: none"> • Director General, MTIA • Chief Executive Officer, MRPV • Director, Transport Property, DOT <p>and the following class of positions:</p> <ul style="list-style-type: none"> • Director, Delivery, MRPV • Program Director, MRPV • Project Director, MRPV 	
Section 155(1)	The project authority may enter an agreement in relation to the time of entry into possession of project land, with the consent of the Project Minister.	<ul style="list-style-type: none"> • Coordinator General, MTIA • Chief Executive Officer, MRPV • Director, Transport Property, DOT <p>and the following class of positions:</p> <ul style="list-style-type: none"> • Director, Delivery, MRPV • Program Director, MRPV • Project Director, MRPV 	

MTPF Act			
Column 1 MTPF Act Provision	Column 2 Summary of Provision	Column 3 Delegates	Column 4 Conditions or Limitations
Section 155(3)	The project authority must serve a copy of the certificate provided under section 155(1)(a) of the MTPF Act on the occupier.	<ul style="list-style-type: none"> • Director General, MTIA • Chief Executive Officer, MRPV • Director, Transport Property, DOT <p>and the following class of positions:</p> <ul style="list-style-type: none"> • Director, Delivery, MRPV • Program Director, MRPV • Project Director, MRPV 	
Section 156	The occupation period for project land may be extended by agreement between the project authority and the occupier of the project land.	<ul style="list-style-type: none"> • Director General, MTIA • Chief Executive Officer, MRPV • Director, Transport Property, DOT <p>and the following class of positions:</p> <ul style="list-style-type: none"> • Director, Delivery, MRPV • Program Director, MRPV • Project Director, MRPV 	
Section 158	Rent payable under the applicable Subdivision of the MTPF Act may be recovered as a debt due to the project authority in any court of competent jurisdiction.	<ul style="list-style-type: none"> • Director General, MTIA • Chief Executive Officer, MRPV • Director, Transport Property, DOT • Director, Commercial & Legal, MRPV 	
Section 159	The project authority may issue a warrant to the sheriff where entitled under the applicable Division to enter into possession of project land and an occupier of project land refuses to give up possession of the land or hinders entry to that land.	<ul style="list-style-type: none"> • Director General, MTIA • Chief Executive Officer, MRPV • Director, Commercial & Legal, MRPV 	

MTPF Act			
Column 1 MTPF Act Provision	Column 2 Summary of Provision	Column 3 Delegates	Column 4 Conditions or Limitations
Section 167	<p>The project authority:</p> <ul style="list-style-type: none"> • section 167(1): may carry out or authorise works on public land inside or outside the project area for the purposes of the approved project; and • section 167(2): must notify any Minister, public authority or Council that owns or manages the public land prior to works being carried out or performed. 	<ul style="list-style-type: none"> • Director General, MTIA • Chief Executive Officer, MRPV • Director, Commercial & Legal, MRPV <p>and the following class of positions:</p> <ul style="list-style-type: none"> • Director, Delivery, MRPV • Program Director, MRPV • Project Director, MRPV 	
Section 168A	<p>The project authority may carry out or authorise associated works where an applicable approval has been granted for those works or is not required.</p>	<ul style="list-style-type: none"> • Director General, MTIA • Chief Executive Officer, MRPV • Director, Commercial & Legal, MRPV <p>and the following class of positions:</p> <ul style="list-style-type: none"> • Director, Delivery, MRPV • Program Director, MRPV • Project Director, MRPV 	
Section 170	<p>The project authority may use or authorise use of any Crown land for the purposes of an approved project.</p>	<ul style="list-style-type: none"> • Director General, MTIA • Chief Executive Officer, MRPV • Director, Commercial & Legal, MRPV <p>and the following class of positions:</p> <ul style="list-style-type: none"> • Director, Delivery, MRPV • Program Director, MRPV • Project Director, MRPV 	

MTPF Act			
Column 1 MTPF Act Provision	Column 2 Summary of Provision	Column 3 Delegates	Column 4 Conditions or Limitations
Section 171	The project authority may carry out or authorise works on any land within an easement acquired under the applicable Part of the MTPF Act.	<ul style="list-style-type: none"> • Director General, MTIA • Chief Executive Officer, MRPV • Director, Commercial & Legal, MRPV <p>and the following class of positions:</p> <ul style="list-style-type: none"> • Director, Delivery, MRPV • Program Director, MRPV • Project Director, MRPV 	
Section 171A	The project authority may transfer to a utility any easement acquired over project land for the purposes of relocating utility infrastructure as a result of an approved project.	<ul style="list-style-type: none"> • Director General, MTIA • Chief Executive Officer, MRPV • Director, Transport Property, DOT • Director, Commercial & Legal, MRPV <p>and the following class of positions:</p> <ul style="list-style-type: none"> • Director, Delivery, MRPV • Program Director, MRPV • Project Director, MRPV 	
Section 173	The project authority may issue a licence to any person to enter and use all or any part of project land that is Crown land, or land that the project authority holds in fee simple, for the purposes of the approved project.	<ul style="list-style-type: none"> • Director General, MTIA • Chief Executive Officer, MRPV • Director, Transport Property, DOT <p>and the following class of positions:</p> <ul style="list-style-type: none"> • Director, Delivery, MRPV • Program Director, MRPV • Project Director, MRPV 	
Section 184	The project authority may enter into an agreement concerning the use or development of surplus land upon or in anticipation of disposing of the whole of its interest in the land.	<ul style="list-style-type: none"> • Director General, MTIA • Chief Executive Officer, MRPV • Director, Transport Property, DOT 	

MTPF Act			
Column 1 MTPF Act Provision	Column 2 Summary of Provision	Column 3 Delegates	Column 4 Conditions or Limitations
Section 185	The project authority may sell, lease or licence any surplus land held in fee simple.	<ul style="list-style-type: none"> • Director General, MTIA • Chief Executive Officer, MRPV • Director, Transport Property, DOT 	
Section 186	<p>The project authority may:</p> <ul style="list-style-type: none"> • open, discontinue, construct, relocate or realign roads, and close any road to traffic; • carry out improvements to roads in the project area; • construct roads over or under roads constructed or to be constructed in the project area; • construct any road in the project area over or under any other roads; and • cause fences, posts, or other structures to be erected along any road constructed or to be constructed in the project area, or across any entrance, approach or means of access to, any road constructed or to be constructed in the project area. 	<ul style="list-style-type: none"> • Director General, MTIA • Chief Executive Officer, MRPV • Director, Commercial & Legal, MRPV <p>and the following class of positions:</p> <ul style="list-style-type: none"> • Director, Delivery, MRPV • Program Director, MRPV • Project Director, MRPV 	
Section 187	The project authority must advise the coordinating road authority before exercising any power under section 186.	<ul style="list-style-type: none"> • Director General, MTIA • Chief Executive Officer, MRPV • Director, Commercial & Legal, MRPV <p>and the following class of positions:</p> <ul style="list-style-type: none"> • Director, Delivery, MRPV • Program Director, MRPV • Project Director, MRPV 	

MTPF Act			
Column 1 MTPF Act Provision	Column 2 Summary of Provision	Column 3 Delegates	Column 4 Conditions or Limitations
Section 189	The project authority must cause notice of a decision under section 186 to be published in the Government Gazette and in a newspaper being circulated throughout the area affected by the decision.	<ul style="list-style-type: none"> • Director General, MTIA • Chief Executive Officer, MRPV • Director, Commercial & Legal, MRPV <p>and the following class of positions:</p> <ul style="list-style-type: none"> • Director, Delivery, MRPV • Program Director, MRPV • Project Director, MRPV 	
Section 190	The project authority may temporarily close a road to traffic for the purposes of an approved project if considered necessary to do so for works on the road or neighbouring land to be carried out.	<ul style="list-style-type: none"> • Director General, MTIA • Chief Executive Officer, MRPV • Director, Commercial & Legal, MRPV <p>and the following class of positions:</p> <ul style="list-style-type: none"> • Director, Delivery, MRPV • Program Director, MRPV • Project Director, MRPV 	
Section 196	The project authority may establish or cause to be established as a 'restricted access area' a the project area or land temporarily occupied under section 75 of the Land Acquisition Compensation Act 1986 by use of fencing, barriers, other temporary or permanent means of physical demarcation or signage on or in proximity to the area.	<ul style="list-style-type: none"> • Director General, MTIA • Chief Executive Officer, MRPV • Director, Commercial & Legal, MRPV <p>and the following class of positions:</p> <ul style="list-style-type: none"> • Director, Delivery, MRPV • Program Director, MRPV • Project Director, MRPV 	

MTPF Act			
Column 1 MTPF Act Provision	Column 2 Summary of Provision	Column 3 Delegates	Column 4 Conditions or Limitations
Section 198	The project authority must issue identity cards to authorised officers appointed for the purposes of exercising functions in respect of restricted access areas.	<ul style="list-style-type: none"> • Director General, MTIA • Chief Executive Officer, MRPV • Director, Commercial & Legal, MRPV <p>and the following class of positions:</p> <ul style="list-style-type: none"> • Director, Delivery, MRPV • Program Director, MRPV • Project Director, MRPV 	
Section 199	The project authority may, by issuing a certificate or making a declaration, authorise a person or class of person to enter and remain in a restricted access area for the purposes of preparing or conducting activities for the purposes of an approved project or carrying out ancillary activities.	<ul style="list-style-type: none"> • Director General, MTIA • Chief Executive Officer, MRPV • Director, Commercial & Legal, MRPV <p>and the following class of positions:</p> <ul style="list-style-type: none"> • Director, Delivery, MRPV • Program Director, MRPV • Project Director, MRPV 	
Sections 200, 201	The project authority may warn any person (other than owner of land or a person authorised in writing by the owner or under the MTPF Act) to leave any part of the restricted access area under the applicable Division of the MTPF Act.	<ul style="list-style-type: none"> • Director General, MTIA • Chief Executive Officer, MRPV • Director, Commercial & Legal, MRPV <p>and the following class of positions:</p> <ul style="list-style-type: none"> • Director, Delivery, MRPV • Program Director, MRPV • Project Director, MRPV 	

MTPF Act			
Column 1 MTPF Act Provision	Column 2 Summary of Provision	Column 3 Delegates	Column 4 Conditions or Limitations
Sections 211, 211A	<p>The project authority:</p> <ul style="list-style-type: none"> • section 211: must take all reasonable steps to identify all utility infrastructure, and every utility that owns such infrastructure, that may be affected by the development of the declared project; and • section 211A: may give a notice to a utility identified under section 211 of the MTPF Act requiring it state whether it owns, operates or controls the relevant utility infrastructure in the specified area, describe the nature of that infrastructure and its location, and provide plans showing the location of that infrastructure. 	<ul style="list-style-type: none"> • Director General, MTIA • Chief Executive Officer, MRPV • Director, Commercial & Legal, MRPV <p>and the following class of positions:</p> <ul style="list-style-type: none"> • Director, Delivery, MRPV • Program Director, MRPV • Project Director, MRPV 	
Section 213	<p>Following the applicable notice period, the project authority may give written notice to a utility of an intention to commence negotiations with the utility for the purpose of entering a utility agreement.</p>	<ul style="list-style-type: none"> • Director General, MTIA • Chief Executive Officer, MRPV • Director, Commercial & Legal, MRPV <p>and the following class of positions:</p> <ul style="list-style-type: none"> • Director, Delivery, MRPV • Program Director, MRPV • Project Director, MRPV 	
Section 214	<p>The project authority (and the relevant utility) must use all reasonable endeavours to negotiate a utility agreement within 50 business days after notice is given under section 213 of the MTPF Act.</p>	<ul style="list-style-type: none"> • Director General, MTIA • Chief Executive Officer, MRPV • Director, Commercial & Legal, MRPV <p>and the following class of positions:</p> <ul style="list-style-type: none"> • Director, Delivery, MRPV • Program Director, MRPV • Project Director, MRPV 	

MTPF Act			
Column 1 MTPF Act Provision	Column 2 Summary of Provision	Column 3 Delegates	Column 4 Conditions or Limitations
Section 215	The project authority must give written notice to the Project Minister and Utility Minister for the utility if a utility agreement is not entered into between the parties within the applicable 50 business day period.	<ul style="list-style-type: none"> • Director General, MTIA • Chief Executive Officer, MRPV • Director, Commercial & Legal, MRPV <p>and the following class of positions:</p> <ul style="list-style-type: none"> • Director, Delivery, MRPV • Program Director, MRPV • Project Director, MRPV 	
Sections 216, 217, 218, 224, 225, 227	<p>The project authority may exercise the following project functions for dispute resolution and termination in relation to a utility agreement:</p> <ul style="list-style-type: none"> • section 216: give notice to the other party that a dispute exists; • section 217: use reasonable endeavours to agree on an expert for resolving the dispute; • section 218: inform the Project Minister if the parties have agreed on an expert to be appointed, or otherwise if there has been no such agreement; • section 224: provide a draft utility agreement that identifies the applicable matters in relation to which the parties do not agree; • section 225: make a submission to the expert in relation to the dispute; and • section 227: agree to termination or revocation of a utility agreement approved in accordance with section 226(4) of the MTPF Act. 	<ul style="list-style-type: none"> • Director General, MTIA • Chief Executive Officer, MRPV • Director, Commercial & Legal, MRPV <p>and the following class of positions:</p> <ul style="list-style-type: none"> • Director, Delivery, MRPV • Program Director, MRPV • Project Director, MRPV 	

MTPF Act			
Column 1 MTPF Act Provision	Column 2 Summary of Provision	Column 3 Delegates	Column 4 Conditions or Limitations
<p>Sections 232, 233, 234</p>	<p>The project authority may exercise the following project functions in relation to unnotified utility infrastructure:</p> <ul style="list-style-type: none"> • section 232: give written notice to utilities of the project authority's intention to remove, relocate or protect the infrastructure (as the case may be), and require the utility to agree to the relevant works or carry out the works itself; • section 233: if the project authority does not receive a response or the utility does not agree to the relevant works specified in a notice provided under section 232 of the MTPF Act, remove, relocate or carry out works in relation to utility infrastructure, and give the utility an estimate of costs for which the utility is liable for; and • section 234: notify the relevant utility of any damage caused to unnotified utility infrastructure, and undertake the applicable protection, relocation or removal activities in respect of utility infrastructure (including, if an emergency situation occurs, taking all reasonable steps to end the emergency). 	<ul style="list-style-type: none"> • Director General, MTIA • Chief Executive Officer, MRPV • Director, Commercial & Legal, MRPV <p>and the following class of positions:</p> <ul style="list-style-type: none"> • Director, Delivery, MRPV • Program Director, MRPV • Project Director, MRPV 	

LACA	Column 1 LACA Provision	Column 2 Summary of Provision	Column 3 Delegates	Column 4 Conditions or Limitations
Section 74 (as modified by section 118(5) of the MTPF Act)		<p>The project authority may, or may authorise another person to:</p> <ul style="list-style-type: none"> • enter and remain upon any land (with assistants, vehicles, machinery or equipment); • affix or establish any trigonometric stations, survey pegs, marks or poles; • undertake flora and fauna surveys, and archaeological investigations; and • dig or bore land, and take samples of soil, rock, ground water or minerals. 	<ul style="list-style-type: none"> • Director General, MTIA • Chief Executive Officer, MRPV • Director, Commercial & Legal, MRPV • Director, Transport Property, DOT <p>and the following class of positions:</p> <ul style="list-style-type: none"> • Director, Delivery, MRPV 	<p>To be exercised by the Director, Transport Property, DOT, unless this is not practicable.</p>
Section 75 (as modified by section 119 of the MTPF Act)		<p>The project authority may, or may authorise another person to enter upon and occupy any land for the purposes:</p> <ul style="list-style-type: none"> • digging and taking from the land any clay, stone, gravel, earth or other substance; • depositing any material on the land; • making cuttings or excavations; • taking timber from the land; • making and using roads on the land; • manufacturing on the land any materials required; • demolishing structures (other than places of residence or business); • carrying out works on drainage channels, steams or other waterways, or works relating to the diversion of drainage channels, streams or other waterways; or • erecting temporary workshops, sheds and buildings. 	<ul style="list-style-type: none"> • Director General, MTIA • Chief Executive Officer, MRPV • Director, Commercial & Legal, MRPV • Director, Transport Property, DOT <p>and the following class of positions:</p> <ul style="list-style-type: none"> • Director, Delivery, MRPV 	<p>To be exercised by the Director, Transport Property, DOT, unless this is not practicable.</p>

**Major Transport Projects Facilitation Act 2009, Transport Integration Act 2010 and
Land Acquisition and Compensation Act 1986**

INSTRUMENT OF DELEGATION BY SECRETARY

SUNBURY ROAD UPGRADE

I, Paul Younis, Secretary to the Department of Transport (**Secretary**) as project authority of the Sunbury Road Upgrade project (**Project**), a declared project for which designation of the project area in accordance with Part 4 of the **Major Transport Projects Facilitation Act 2009** (Vic.) (**MTPF Act**) occurred on 27 March 2020, and as project authority being also:

- taken to be specified as a determining referral authority in the Hume Planning Scheme under the **Planning and Environment Act 1987** (Vic.) (**Planning and Environment Act 1987**) by operation of section 102A of the MTPF Act (**determining referral authority**); and
- the Authority for the purpose of the **Land Acquisition and Compensation Act 1986** (Vic.) (**LACA**) as applied by section 113 of the MTPF Act (**Authority**) –

in exercise of the powers vested in me under section 104 of the MTPF Act, section 39 of the **Transport Integration Act 2010** and any and all other enabling powers, hereby delegate to the person(s) from time to time employed within the Department of Transport (**DOT**) (which includes the Major Transport Infrastructure Authority, the administrative office existing in relation to DOT that is responsible for delivery of the Project (**MTIA**) and occupying the positions specified in Column 3 of the Schedule to this instrument (each a **Delegate**) such of:

- the project functions and powers conferred on me under the MTPF Act in respect of the Project;
- my powers, duties and functions as determining referral authority in relation to land in the project area; and
- my powers and functions as the Authority –

as are specified for the Delegate in Column 1 and summarised in Column 2 of the Schedule to this instrument, subject to the following conditions and limitations:

3. any condition or limitation that is specified in Column 4 of the Schedule to this instrument with respect to a power, duty or function that is specified in Column 1 of the Schedule to this instrument; and
4. the condition that the power, duty or function may only be exercised for the purpose of the Project.

If the Delegate considers that a project function is one that, in the particular circumstances, requires referral to the Secretary, then before exercising the project function the Delegate should inform and consult with the Secretary.

In the interpretation of this instrument, the summary of a provision set out in Column 2 of the Schedule to this instrument is for convenience only and, unless a contrary intention appears, does not amend, substitute or delete any part of a provision of the MTPF Act or LACA set out in Column 1 of the Schedule to this instrument or otherwise affect the scope or effect of the power, duty or function delegated.

A Delegate is not authorised to delegate or sub-delegate any power delegated under this instrument.

This delegation will remain valid until it is revoked.

The delegation I signed on 23 April 2020 delegating to persons employed within DOT certain powers, duties and functions in respect of the Project, is hereby revoked.

Dated 2 September 2020

PAUL YOUNIS
Secretary to the Department of Transport

SCHEDULE

MTPF Act			
Column 1 MTPF Act Provision	Column 2 Summary of Provision	Column 3 Delegates	Column 4 Conditions or Limitations
Section 96	The project authority may request the Planning Minister to vary the project area for the approved project.	<ul style="list-style-type: none"> • Director General, MTIA • Chief Executive Officer, Major Road Projects Victoria (MRPV) • Director, Commercial & Legal, MRPV 	
Section 101	<p>The project authority may exercise the project authority's functions, summarised as follows:</p> <ul style="list-style-type: none"> • section 101(a): facilitating development of the approved project; • sections 101(b), (c): evaluating submissions from and negotiating with interested parties; • sections 101(d), (e), (f): making recommendations in relation to, and entering and administering contractual arrangements for, development or delivery of the approved project; • sections 101(g), (h), (i): facilitating and coordinating consultations, and negotiating and entering into arrangements, and coordinating, with statutory authorities, agencies of the State and other bodies or persons involved in, or affected by, development or operation of the approved project; • section 101(i): making recommendations to the Project Minister in relation to facilitating the approved project; • section 101(j): ensuring that agreements and arrangements between the State and any other person for, or relating to, the development or delivery of the e approved project are performed in accordance with their terms; • section 101(k): commissioning transport infrastructure that is developed as part of the approved project; • section 101(l): undertaking any other functions conferred on the project authority under the MTPF Act or any other Act. 	<ul style="list-style-type: none"> • Director General, MTIA • Chief Executive Officer, MRPV • Director, Commercial & Legal, MRPV <p>and the following class of positions:</p> <ul style="list-style-type: none"> • Director, Delivery, MRPV 	

MTPF Act			
Column 1 MTPF Act Provision	Column 2 Summary of Provision	Column 3 Delegates	Column 4 Conditions or Limitations
Section 102	<p>For the purpose of performing its functions, and in addition to all other powers conferred on it by or under any other Act or law, exercising:</p> <ul style="list-style-type: none"> • section 102(1): a specified project power or power conferred on it by or under the MTPF Act; and • Section 102(2): do all other things necessary or convenient to be done for, or in connection with, or as incidental to, the performance of project functions under the MTPF Act. 	<ul style="list-style-type: none"> • Director General, MTIA • Chief Executive Officer, MRPV • Director, Commercial & Legal, MRPV • Director, Transport Property, DOT <p>and the following class of positions:</p> <ul style="list-style-type: none"> • Director, Delivery, MRPV 	
Section 102A	<p>The project authority for an approved project is taken to be specified as a determining referral authority in any planning scheme under the Planning and Environment Act.</p>	<ul style="list-style-type: none"> • Director General, MTIA • Chief Executive Officer, MRPV • Director, Commercial and Legal, MRPV <p>and the following class of positions:</p> <ul style="list-style-type: none"> • Director, Delivery, MRPV • Program Director, MRPV • Project Director, MRPV 	
Section 110	<p>On completion of an approved project, the project authority must notify the Project Minister of the project's completion.</p>	<ul style="list-style-type: none"> • Director General, MTIA • Chief Executive Officer, MRPV 	
Section 112	<p>The project authority may acquire an interest in land in the project area by agreement or by a compulsory process for the purposes of an approved project or any purpose connected with the approved project.</p>	<ul style="list-style-type: none"> • Director, Transport Property, DOT • Director General, MTIA • Chief Executive Officer, MRPV <p>and the following class of positions:</p> <ul style="list-style-type: none"> • Director, Delivery, MRPV 	<p>To be exercised by the Director, Transport Property, DOT, unless this is not practicable.</p> <p>Before acquiring an interest in any land, the delegate must give the Secretary particulars of the land and obtain the Secretary's approval in writing for the acquisition of that land.</p>

MTPF Act			
Column 1 MTPF Act Provision	Column 2 Summary of Provision	Column 3 Delegates	Column 4 Conditions or Limitations
Section 120(4), 120(5)	<p>The project authority must:</p> <ul style="list-style-type: none"> • section 120(4): make an offer for the payment of rent to the owner of the land for the authority's occupation of that land; and • section 120(5): if an amount of rent to be paid is not agreed upon, notify the Valuer-General in writing of any disagreement with an owner of land as to the amount of rent to be paid. 	<ul style="list-style-type: none"> • Director General, MTIA • Chief Executive Officer, MRPV • Director, Transport Property, DOT <p>and the following class of positions:</p> <ul style="list-style-type: none"> • Director, Delivery, MRPV 	
Section 121	<p>The project authority must:</p> <ul style="list-style-type: none"> • give the owner of land a condition report; • negotiate the contents of the condition report should the owner disagree; and • failing which, notify the Valuer General of a dispute under this section. 	<ul style="list-style-type: none"> • Director General, MTIA • Chief Executive Officer, MRPV • Director, Transport Property, DOT <p>and the following class of positions:</p> <ul style="list-style-type: none"> • Director, Delivery, MRPV • Program Director, MRPV • Project Director, MRPV 	
Section 123	<p>A project authority may transfer a building or structure in full or in part settlement of any compensation that the project authority is liable to pay.</p>	<ul style="list-style-type: none"> • Director General, MTIA • Chief Executive Officer, MRPV • Director, Transport Property, DOT 	
Section 124	<p>If a project authority acquires compulsorily under Division 1 of Part 6 to the MTPF Act part of a parcel of land owned by a person, the project authority may require that person to take as compensation land that adjoins the part of the parcel that was not acquired; and that is owned by the project authority or is surplus land.</p>	<ul style="list-style-type: none"> • Director General, MTIA • Chief Executive Officer, MRPV • Director, Transport Property, DOT 	

MTPF Act			
Column 1 MTPF Act Provision	Column 2 Summary of Provision	Column 3 Delegates	Column 4 Conditions or Limitations
Sections 127, 129	<p>The project authority is authorised to:</p> <ul style="list-style-type: none"> section 127: compulsorily acquire a native title right or interest in land in the project area for the purposes of an approved project or any purpose connected with an approved project; section 129: comply with relevant procedures under the Native Title Act 1993 (Vic.) for acquisition of native title rights and interests. 	<ul style="list-style-type: none"> Director General, MTIA Chief Executive Officer, MRPV Director, Transport Property, DOT 	<p>To be exercised by the Director, Transport Property, DOT, unless this is not practicable.</p> <p>Before acquiring a native title right or interest in land in the project area, the delegate must give the Secretary particulars of the land and obtain the Secretary's approval in writing for the acquisition of that right or interest.</p>
Section 133	<p>The project authority may purchase land outside the project area for the purposes of an approved project, or preservation, restoration or provision of native habitat.</p>	<ul style="list-style-type: none"> Director General, MTIA Chief Executive Officer, MRPV Director, Transport Property, DOT <p>and the following class of positions:</p> <ul style="list-style-type: none"> Director, Delivery, MRPV 	<p>To be exercised by the Director, Transport Property, DOT, unless this is not practicable.</p> <p>Before purchasing any land outside the project area, the delegate must give the Secretary particulars of the land and obtain the Secretary's approval in writing for the purchase of that land.</p>
Section 137B	<p>The project authority may request the consent of the Project Minister to the surrender to the Crown of land held in fee simple if the land is intended to form part of a lease of land under section 177 of the MTPF Act.</p>	<ul style="list-style-type: none"> Director General, MTIA Chief Executive Officer, MRPV Director, Transport Property, DOT 	
Section 143	<p>The project authority must notify the Minister administering the Crown Land (Reserves) Act 1978 (Vic.) of reservation of land under Subdivision 1, 2 or 2A or Division 6 of the MTPF Act.</p>	<ul style="list-style-type: none"> Director General, MTIA Chief Executive Officer, MRPV Director, Transport Property, DOT 	

MTPF Act			
Column 1 MTPF Act Provision	Column 2 Summary of Provision	Column 3 Delegates	Column 4 Conditions or Limitations
Section 147	The project authority may transfer a building or structure from project land or project authority-owned land or Council-owned land, to other land owned by the Council as compensation.	<ul style="list-style-type: none"> • Director General, MTIA • Chief Executive Officer, MRPV • Director, Transport Property, DOT 	
Section 148	The project authority may require that adjoining land is provided as compensation to Council for land acquired compulsorily.	<ul style="list-style-type: none"> • Director General, MTIA • Chief Executive Officer, MRPV • Director, Transport Property, DOT 	
Section 151	The project authority may enter into possession of project land.	<ul style="list-style-type: none"> • Director General, MTIA • Chief Executive Officer, MRPV • Director, Transport Property, DOT <p>and the following class of positions:</p> <ul style="list-style-type: none"> • Director, Delivery, MRPV 	
Section 152	The project authority must diligently endeavour to obtain agreement with the occupier of project land on terms for entry into possession of the land.	<ul style="list-style-type: none"> • Director General, MTIA • Chief Executive Officer, MRPV • Director, Transport Property, DOT <p>and the following class of positions:</p> <ul style="list-style-type: none"> • Director, Delivery, MRPV • Program Director, MRPV • Project Director, MRPV 	
Section 155(1)	The project authority may enter an agreement in relation to the time of entry into possession of project land, with the consent of the Project Minister.	<ul style="list-style-type: none"> • Coordinator General, MTIA • Chief Executive Officer, MRPV • Director, Transport Property, DOT <p>and the following class of positions:</p> <ul style="list-style-type: none"> • Director, Delivery, MRPV • Program Director, MRPV • Project Director, MRPV 	

MTPF Act			
Column 1 MTPF Act Provision	Column 2 Summary of Provision	Column 3 Delegates	Column 4 Conditions or Limitations
Section 155(3)	The project authority must serve a copy of the certificate provided under section 155(1)(a) of the MTPF Act on the occupier.	<ul style="list-style-type: none"> • Director General, MTIA • Chief Executive Officer, MRPV • Director, Transport Property, DOT <p>and the following class of positions:</p> <ul style="list-style-type: none"> • Director, Delivery, MRPV • Program Director, MRPV • Project Director, MRPV 	
Section 156	The occupation period for project land may be extended by agreement between the project authority and the occupier of the project land.	<ul style="list-style-type: none"> • Director General, MTIA • Chief Executive Officer, MRPV • Director, Transport Property, DOT <p>and the following class of positions:</p> <ul style="list-style-type: none"> • Director, Delivery, MRPV • Program Director, MRPV • Project Director, MRPV 	
Section 158	Rent payable under the applicable Subdivision of the MTPF Act may be recovered as a debt due to the project authority in any court of competent jurisdiction.	<ul style="list-style-type: none"> • Director General, MTIA • Chief Executive Officer, MRPV • Director, Transport Property, DOT • Director, Commercial & Legal, MRPV 	
Section 159	The project authority may issue a warrant to the sheriff where entitled under the applicable Division to enter into possession of project land and an occupier of project land refuses to give up possession of the land or hinders entry to that land.	<ul style="list-style-type: none"> • Director General, MTIA • Chief Executive Officer, MRPV • Director, Commercial & Legal, MRPV 	

MTPF Act			
Column 1 MTPF Act Provision	Column 2 Summary of Provision	Column 3 Delegates	Column 4 Conditions or Limitations
Section 167	<p>The project authority:</p> <ul style="list-style-type: none"> • section 167(1): may carry out or authorise works on public land inside or outside the project area for the purposes of the approved project; and • section 167(2): must notify any Minister, public authority or Council that owns or manages the public land prior to works being carried out or performed. 	<ul style="list-style-type: none"> • Director General, MTIA • Chief Executive Officer, MRPV • Director, Commercial & Legal, MRPV <p>and the following class of positions:</p> <ul style="list-style-type: none"> • Director, Delivery, MRPV • Program Director, MRPV • Project Director, MRPV 	
Section 168A	<p>The project authority may carry out or authorise associated works where an applicable approval has been granted for those works or is not required.</p>	<ul style="list-style-type: none"> • Director General, MTIA • Chief Executive Officer, MRPV • Director, Commercial & Legal, MRPV <p>and the following class of positions:</p> <ul style="list-style-type: none"> • Director, Delivery, MRPV • Program Director, MRPV • Project Director, MRPV 	
Section 170	<p>The project authority may use or authorise use of any Crown land for the purposes of an approved project.</p>	<ul style="list-style-type: none"> • Director General, MTIA • Chief Executive Officer, MRPV • Director, Commercial & Legal, MRPV <p>and the following class of positions:</p> <ul style="list-style-type: none"> • Director, Delivery, MRPV • Program Director, MRPV • Project Director, MRPV 	

MTPF Act			
Column 1 MTPF Act Provision	Column 2 Summary of Provision	Column 3 Delegates	Column 4 Conditions or Limitations
Section 171	The project authority may carry out or authorise works on any land within an easement acquired under the applicable Part of the MTPF Act.	<ul style="list-style-type: none"> • Director General, MTIA • Chief Executive Officer, MRPV • Director, Commercial & Legal, MRPV <p>and the following class of positions:</p> <ul style="list-style-type: none"> • Director, Delivery, MRPV • Program Director, MRPV • Project Director, MRPV 	
Section 171A	The project authority may transfer to a utility any easement acquired over project land for the purposes of relocating utility infrastructure as a result of an approved project.	<ul style="list-style-type: none"> • Director General, MTIA • Chief Executive Officer, MRPV • Director, Transport Property, DOT • Director, Commercial & Legal, MRPV <p>and the following class of positions:</p> <ul style="list-style-type: none"> • Director, Delivery, MRPV • Program Director, MRPV • Project Director, MRPV 	
Section 173	The project authority may issue a licence to any person to enter and use all or any part of project land that is Crown land, or land that the project authority holds in fee simple, for the purposes of the approved project.	<ul style="list-style-type: none"> • Director General, MTIA • Chief Executive Officer, MRPV • Director, Transport Property, DOT <p>and the following class of positions:</p> <ul style="list-style-type: none"> • Director, Delivery, MRPV • Program Director, MRPV • Project Director, MRPV 	
Section 184	The project authority may enter into an agreement concerning the use or development of surplus land upon or in anticipation of disposing of the whole of its interest in the land.	<ul style="list-style-type: none"> • Director General, MTIA • Chief Executive Officer, MRPV • Director, Transport Property, DOT 	

MTPF Act			
Column 1 MTPF Act Provision	Column 2 Summary of Provision	Column 3 Delegates	Column 4 Conditions or Limitations
Section 185	The project authority may sell, lease or licence any surplus land held in fee simple.	<ul style="list-style-type: none"> • Director General, MTIA • Chief Executive Officer, MRPV • Director, Transport Property, DOT 	
Section 186	The project authority may: <ul style="list-style-type: none"> • open, discontinue, construct, relocate or realign roads, and close any road to traffic; • carry out improvements to roads in the project area; • construct roads over or under roads constructed or to be constructed in the project area; • construct any road in the project area over or under any other roads; and • cause fences, posts, or other structures to be erected along any road constructed or to be constructed in the project area, or across any entrance, approach or means of access to, any road constructed or to be constructed in the project area. 	<ul style="list-style-type: none"> • Director General, MTIA • Chief Executive Officer, MRPV • Director, Commercial & Legal, MRPV <p>and the following class of positions:</p> <ul style="list-style-type: none"> • Director, Delivery, MRPV • Program Director, MRPV • Project Director, MRPV 	
Section 187	The project authority must advise the coordinating road authority before exercising any power under section 186.	<ul style="list-style-type: none"> • Director General, MTIA • Chief Executive Officer, MRPV • Director, Commercial & Legal, MRPV <p>and the following class of positions:</p> <ul style="list-style-type: none"> • Director, Delivery, MRPV • Program Director, MRPV • Project Director, MRPV 	

MTPF Act			
Column 1 MTPF Act Provision	Column 2 Summary of Provision	Column 3 Delegates	Column 4 Conditions or Limitations
Section 189	The project authority must cause notice of a decision under section 186 to be published in the Government Gazette and in a newspaper being circulated throughout the area affected by the decision.	<ul style="list-style-type: none"> • Director General, MTIA • Chief Executive Officer, MRPV • Director, Commercial & Legal, MRPV <p>and the following class of positions:</p> <ul style="list-style-type: none"> • Director, Delivery, MRPV • Program Director, MRPV • Project Director, MRPV 	
Section 190	The project authority may temporarily close a road to traffic for the purposes of an approved project if considered necessary to do so for works on the road or neighbouring land to be carried out.	<ul style="list-style-type: none"> • Director General, MTIA • Chief Executive Officer, MRPV • Director, Commercial & Legal, MRPV <p>and the following class of positions:</p> <ul style="list-style-type: none"> • Director, Delivery, MRPV • Program Director, MRPV • Project Director, MRPV 	
Section 196	The project authority may establish or cause to be established as a "restricted access area" a the project area or land temporarily occupied under section 75 of the Land Acquisition Compensation Act 1986 by use of fencing, barriers, other temporary or permanent means of physical demarcation or signage on or in proximity to the area.	<ul style="list-style-type: none"> • Director General, MTIA • Chief Executive Officer, MRPV • Director, Commercial & Legal, MRPV <p>and the following class of positions:</p> <ul style="list-style-type: none"> • Director, Delivery, MRPV • Program Director, MRPV • Project Director, MRPV 	

MTPF Act			
Column 1 MTPF Act Provision	Column 2 Summary of Provision	Column 3 Delegates	Column 4 Conditions or Limitations
Section 198	The project authority must issue identity cards to authorised officers appointed for the purposes of exercising functions in respect of restricted access areas.	<ul style="list-style-type: none"> • Director General, MTIA • Chief Executive Officer, MRPV • Director, Commercial & Legal, MRPV <p>and the following class of positions:</p> <ul style="list-style-type: none"> • Director, Delivery, MRPV • Program Director, MRPV • Project Director, MRPV 	
Section 199	The project authority may, by issuing a certificate or making a declaration, authorise a person or class of person to enter and remain in a restricted access area for the purposes of preparing or conducting activities for the purposes of an approved project or carrying out ancillary activities.	<ul style="list-style-type: none"> • Director General, MTIA • Chief Executive Officer, MRPV • Director, Commercial & Legal, MRPV <p>and the following class of positions:</p> <ul style="list-style-type: none"> • Director, Delivery, MRPV • Program Director, MRPV • Project Director, MRPV 	
Sections 200, 201	The project authority may warn any person (other than owner of land or a person authorised in writing by the owner or under the MTPF Act) to leave any part of the restricted access area under the applicable Division of the MTPF Act.	<ul style="list-style-type: none"> • Director General, MTIA • Chief Executive Officer, MRPV • Director, Commercial & Legal, MRPV <p>and the following class of positions:</p> <ul style="list-style-type: none"> • Director, Delivery, MRPV • Program Director, MRPV • Project Director, MRPV 	

MTPF Act	Column 1 MTPF Act Provision	Column 2 Summary of Provision	Column 3 Delegates	Column 4 Conditions or Limitations
Sections 211, 211A		<p>The project authority:</p> <ul style="list-style-type: none"> • section 211: must take all reasonable steps to identify all utility infrastructure, and every utility that owns such infrastructure, that may be affected by the development of the declared project; and • section 211A: may give a notice to a utility identified under section 211 of the MTPF Act requiring it state whether it owns, operates or controls the relevant utility infrastructure in the specified area, describe the nature of that infrastructure and its location, and provide plans showing the location of that infrastructure. 	<ul style="list-style-type: none"> • Director General, MTIA • Chief Executive Officer, MRPV • Director, Commercial & Legal, MRPV <p>and the following class of positions:</p> <ul style="list-style-type: none"> • Director, Delivery, MRPV • Program Director, MRPV • Project Director, MRPV 	
Section 213		<p>Following the applicable notice period, the project authority may give written notice to a utility of an intention to commence negotiations with the utility for the purpose of entering a utility agreement.</p>	<ul style="list-style-type: none"> • Director General, MTIA • Chief Executive Officer, MRPV • Director, Commercial & Legal, MRPV <p>and the following class of positions:</p> <ul style="list-style-type: none"> • Director, Delivery, MRPV • Program Director, MRPV • Project Director, MRPV 	
Section 214		<p>The project authority (and the relevant utility) must use all reasonable endeavours to negotiate a utility agreement within 50 business days after notice is given under section 213 of the MTPF Act.</p>	<ul style="list-style-type: none"> • Director General, MTIA • Chief Executive Officer, MRPV • Director, Commercial & Legal, MRPV <p>and the following class of positions:</p> <ul style="list-style-type: none"> • Director, Delivery, MRPV • Program Director, MRPV • Project Director, MRPV 	

MTPF Act			
Column 1 MTPF Act Provision	Column 2 Summary of Provision	Column 3 Delegates	Column 4 Conditions or Limitations
Section 215	The project authority must give written notice to the Project Minister and Utility Minister for the utility if a utility agreement is not entered into between the parties within the applicable 50 business day period.	<ul style="list-style-type: none"> • Director General, MTIA • Chief Executive Officer, MRPV • Director, Commercial & Legal, MRPV <p>and the following class of positions:</p> <ul style="list-style-type: none"> • Director, Delivery, MRPV • Program Director, MRPV • Project Director, MRPV 	
Sections 216, 217, 218, 224, 225, 227	<p>The project authority may exercise the following project functions for dispute resolution and termination in relation to a utility agreement:</p> <ul style="list-style-type: none"> • section 216: give notice to the other party that a dispute exists; • section 217: use reasonable endeavours to agree on an expert for resolving the dispute; • section 218: inform the Project Minister if the parties have agreed on an expert to be appointed, or otherwise if there has been no such agreement; • section 224: provide a draft utility agreement that identifies the applicable matters in relation to which the parties do not agree; • section 225: make a submission to the expert in relation to the dispute; and • section 227: agree to termination or revocation of a utility agreement approved in accordance with section 226(4) of the MTPF Act. 	<ul style="list-style-type: none"> • Director General, MTIA • Chief Executive Officer, MRPV • Director, Commercial & Legal, MRPV <p>and the following class of positions:</p> <ul style="list-style-type: none"> • Director, Delivery, MRPV • Program Director, MRPV • Project Director, MRPV 	

MTPF Act			
Column 1 MTPF Act Provision	Column 2 Summary of Provision	Column 3 Delegates	Column 4 Conditions or Limitations
Sections 232, 233, 234	<p>The project authority may exercise the following project functions in relation to unnotified utility infrastructure:</p> <ul style="list-style-type: none"> • section 232: give written notice to utilities of the project authority's intention to remove, relocate or protect the infrastructure (as the case may be), and require the utility to agree to the relevant works or carry out the works itself; • section 233: if the project authority does not receive a response or the utility does not agree to the relevant works specified in a notice provided under section 232 of the MTPF Act, remove, relocate or carry out works in relation to utility infrastructure, and give the utility an estimate of costs for which the utility is liable for; and • section 234: notify the relevant utility of any damage caused to unnotified utility infrastructure, and undertake the applicable protection, relocation or removal activities in respect of utility infrastructure (including, if an emergency situation occurs, taking all reasonable steps to end the emergency). 	<ul style="list-style-type: none"> • Director General, MTIA • Chief Executive Officer, MRPV • Director, Commercial & Legal, MRPV <p>and the following class of positions:</p> <ul style="list-style-type: none"> • Director, Delivery, MRPV • Program Director, MRPV • Project Director, MRPV 	

LACA	Column 1 LACA Provision	Column 2 Summary of Provision	Column 3 Delegates	Column 4 Conditions or Limitations
Section 74 (as modified by section 118(5) of the MTPF Act)	<p>The project authority may, or may authorise another person to:</p> <ul style="list-style-type: none"> • enter and remain upon any land (with assistants, vehicles, machinery or equipment); • affix or establish any trigonometric stations, survey pegs, marks or poles; • undertake flora and fauna surveys, and archaeological investigations; and • dig or bore land, and take samples of soil, rock, ground water or minerals. 	<ul style="list-style-type: none"> • Director General, MTIA • Chief Executive Officer, MRPV • Director, Commercial & Legal, MRPV • Director, Transport Property, DOT <p>and the following class of positions:</p> <ul style="list-style-type: none"> • Director, Delivery, MRPV 	<p>To be exercised by the Director, Transport Property, DOT, unless this is not practicable.</p>	
Section 75 (as modified by section 119 of the MTPF Act)	<p>The project authority may, or may authorise another person to enter upon and occupy any land for the purposes:</p> <ul style="list-style-type: none"> • digging and taking from the land any clay, stone, gravel, earth or other substance; • depositing any material on the land; • making cuttings or excavations; • taking timber from the land; • making and using roads on the land; • manufacturing on the land any materials required; • demolishing structures (other than places of residence or business); • carrying out works on drainage channels, streams or other waterways, or works relating to the diversion of drainage channels, streams or other waterways; or • erecting temporary workshops, sheds and buildings. 	<ul style="list-style-type: none"> • Director General, MTIA • Chief Executive Officer, MRPV • Director, Commercial & Legal, MRPV • Director, Transport Property, DOT <p>and the following class of positions:</p> <ul style="list-style-type: none"> • Director, Delivery, MRPV 	<p>To be exercised by the Director, Transport Property, DOT, unless this is not practicable.</p>	

Planning and Environment Act 1987

BALLARAT PLANNING SCHEME

Notice of Approval of Amendment

Amendment C216ballpt2

The Minister for Planning has approved Amendment C216ballpt2 to the Ballarat Planning Scheme.

The Amendment comes into operation on the date this notice is published in the Victoria Government Gazette.

The Amendment rezones land at 15 Lake View Court, Ballarat North, from Public Park and Recreation Zone to Schedule 1 to the General Residential Zone.

A copy of the Amendment can be inspected, free of charge, at the Department of Environment, Land, Water and Planning website at www.planning.vic.gov.au/public-inspection and free of charge, at the Ballarat City Council website, www.ballarat.vic.gov.au; or during office hours, at the offices of the Ballarat City Council, The Phoenix, 25 Armstrong Street South, Ballarat.

STUART MENZIES

Director

State Planning Services

Department of Environment, Land, Water and Planning

Planning and Environment Act 1987

CARDINIA PLANNING SCHEME

Notice of Approval of Amendment

Amendment C241card

The Minister for Planning has approved Amendment C241card to the Cardinia Planning Scheme.

The Amendment comes into operation on the date this notice is published in the Victoria Government Gazette.

The Amendment applies the Public Acquisition Overlay 3 to five parcels of land to facilitate intersection development in accordance with the Officer Precinct Structure Plan and Officer Development Contributions Plan.

A copy of the Amendment can be inspected, free of charge, at the Department of Environment, Land, Water and Planning website at www.planning.vic.gov.au/public-inspection and free of charge, at the Cardinia Shire Council website, www.cardinia.vic.gov.au; or during office hours, at the offices of the Cardinia Shire Council, 20 Siding Avenue, Officer, Victoria 3809.

STUART MENZIES

Director

State Planning Services

Department of Environment, Land, Water and Planning

Planning and Environment Act 1987
CORANGAMITE PLANNING SCHEME
Notice of Approval of Amendment
Amendment C52cora

The Minister for Planning has approved Amendment C52cora to the Corangamite Planning Scheme.

The Amendment comes into operation on the date this notice is published in the Victoria Government Gazette.

The Amendment replaces the Local Planning Policy Framework of the Corangamite Planning Scheme with a new Municipal Planning Strategy at Clause 02, a modified Planning Policy Framework at Clauses 11–19, and a selected number of local schedules of overlays, particular provisions and operational provisions in a manner consistent with changes to the Victoria Planning Provisions introduced by Amendment VC148.

A copy of the Amendment can be inspected, free of charge, at the Department of Environment, Land, Water and Planning website at www.planning.vic.gov.au/public-inspection and free of charge at: the Corangamite Shire Council website at www.corangamite.vic.gov.au; or during office hours, at the offices of the Corangamite Shire Council, 181 Manifold Street, Camperdown.

STUART MENZIES
Director
State Planning Services
Department of Environment, Land, Water and Planning

Planning and Environment Act 1987
GREATER DANDENONG PLANNING SCHEME
Notice of Approval of Amendment
Amendment C226gdan

The Minister for Planning has approved Amendment C226gdan to the Greater Dandenong Planning Scheme.

The Amendment comes into operation on the date this notice is published in the Victoria Government Gazette.

The Amendment applies a Specific Controls Overlay (SCO11) to 27 Wilma Avenue, Dandenong, to facilitate the development of a three-storey residential building consisting 10 dwellings for low-income Aboriginal people in Victoria, and makes associated changes to the planning scheme.

A copy of the Amendment can be inspected, free of charge, at the Department of Environment, Land, Water and Planning website at www.planning.vic.gov.au/public-inspection and free of charge at: the Greater Dandenong City Council website at www.greaterdandenong.com; or during office hours, at the offices of the Greater Dandenong City Council, Dandenong Civic Centre, 225 Lonsdale Street, Dandenong.

STUART MENZIES
Director
State Planning Services
Department of Environment, Land, Water and Planning

Planning and Environment Act 1987
GREATER GEELONG PLANNING SCHEME
Notice of Approval of Amendment
Amendment C420ggee

The Minister for Planning has approved Amendment C420ggee to the Greater Geelong Planning Scheme.

The Amendment comes into operation on the date this notice is published in the Victoria Government Gazette.

The Amendment applies an interim Heritage Overlay to the land at 12–16 Kinsmead Street, Waurin Ponds, until 31 December 2021.

A copy of the Amendment can be inspected, free of charge, at the Department of Environment, Land, Water and Planning website at www.planning.vic.gov.au/public-inspection and free of charge at the City of Greater Geelong website, www.geelongaustralia.com.au/amendments/; or during office hours, at the offices of the City of Greater Geelong, 100 Brougham Street, Geelong.

STUART MENZIES
Director
State Planning Services
Department of Environment, Land, Water and Planning

Planning and Environment Act 1987
MORELAND PLANNING SCHEME
Notice of Approval of Amendment
Amendment C206more

The Minister for Planning has approved Amendment C206more to the Moreland Planning Scheme.

The Amendment comes into operation on the date this notice is published in the Victoria Government Gazette.

The Amendment rezones land at 49 Sages Road, Glenroy, from Industrial 1 Zone to Public Use Zone Schedule 5 and modifies the schedule to the Public Use Zone to apply conditions to development of the site, to facilitate its use for cemetery.

A copy of the Amendment can be inspected, free of charge, at the Department of Environment, Land, Water and Planning website at www.planning.vic.gov.au/public-inspection and free of charge, at the Moreland City Council website, www.moreland.vic.gov.au; or during office hours, at the offices of the Moreland City Council, 90 Bell Street, Coburg.

STUART MENZIES
Director
State Planning Services
Department of Environment, Land, Water and Planning

Planning and Environment Act 1987
MOUNT ALEXANDER PLANNING SCHEME
Notice of Approval of Amendment
Amendment C93malx

The Minister for Planning has approved Amendment C93malx to the Mount Alexander Planning Scheme.

The Amendment comes into operation on the date this notice is published in the Victoria Government Gazette.

The Amendment alters the planning scheme maps and the Schedule to the Heritage Overlay so that the Mount Alexander Planning Scheme is consistent with the Victorian Heritage Register.

A copy of the Amendment can be inspected, free of charge, at the Department of Environment, Land, Water and Planning website at www.planning.vic.gov.au/public-inspection and free of charge, at the Mount Alexander Shire Council website, www.mountalexander.vic.gov.au; or during office hours at the Mount Alexander Shire Council, Civic Centre, corner Lyttleton Street and Lloyd Street, Castlemaine, Victoria 3450.

STUART MENZIES
Director
State Planning Services
Department of Environment, Land, Water and Planning

ORDERS IN COUNCIL

Crown Land (Reserves) Act 1978

REVOCATION OF TEMPORARY RESERVATIONS

Order in Council

The Governor in Council under section 10 of the **Crown Land (Reserves) Act 1978** revokes the following temporary reservations:

FITZROY – The temporary reservation by Order in Council of 11 November, 1868 of an area of 6020 square metres of land At Fitzroy, Parish of Jika Jika as a site for Public Baths. – File ref: Rs 11941

SALE – The temporary reservation by Order in Council of 5 February, 1974 of an area of 1.06 hectares, more or less, of land in the Township of Sale, Parish of Sale as a site for a State (High) School, described as Crown Allotment 2, Section 6, less any authorized excisions; with reservation purpose amended to Educational purposes by Order in Council of 1 August, 1995 and published in the Government Gazette of 3 August, 1995 page – 2038 so far as the balance remaining. – File ref: 1505998

SOUTH MELBOURNE – The temporary reservation by Order in Council of 1 September, 2009 of an area of 2415 square metres of land described as Crown Allotment 2207, City of South Melbourne, Parish of Melbourne South as a site for Public Recreation **so far only** as the portion containing 302 square metres being Crown Allotment 2396, City of South Melbourne, Parish of Melbourne South as shown on Original Plan No. OP125013 lodged in the Central Plan Office. – File ref: 2018018

WOOLAMAI – The temporary reservation by Order in Council of 21 April, 2020 of various parcels of land in the Parishes of Jeetho West, Jumbanna, Corinella and Woolamai and Township of Woolamai as a site for Public purposes (Rail Trail), **so far only** as the portion containing 1208 square metres being Crown Allotment 2056, Parish of Woolamai as shown on Original Plan No. OP124792 lodged in the Central Plan Office. – File ref: 2000841

This Order comes into effect on the date it is published in the Government Gazette.

Dated 15 September 2020

Responsible Minister

HON LILY D'AMBROSIO MP

Minister for Energy, Environment and Climate Change

CLAIRE CHISHOLM
Clerk of the Executive Council

Crown Land (Reserves) Act 1978

TEMPORARY RESERVATION OF CROWN LANDS

Order in Council

The Governor in Council under section 4(1) of the **Crown Land (Reserves) Act 1978** temporarily reserves the following Crown lands which are required for the purposes mentioned:–

MUNICIPAL DISTRICT OF THE MANSFIELD SHIRE COUNCIL

BRANKEET – Water supply purposes; area 1.652 hectares, being Crown Allotment 2021, Parish of Brankeet as shown on Original Plan No. OP124388 lodged in the Central Plan Office. – File ref: Rs 06769

MUNICIPAL DISTRICT OF THE SWAN HILL RURAL CITY COUNCIL

BUMBANG – Conservation of an area of natural and cultural interest; being Crown Allotments 15 [area 32 hectares, more or less], 16 [area 68.9 hectares, more or less] and 17 [area 518 hectares, more or less], Section A, and 2058 [area 3.6 hectares, more or less], 2059 [area 11.5 hectares, more or less] and 2060 [area 11 hectares, more or less], Parish of Bumbang as shown hatched on Plan No. LEGL./17-365 lodged in the Central Plan Office. – File ref: L6-11372

MUNICIPAL DISTRICT OF THE FRANKSTON CITY COUNCIL

FRANKSTON – Public Recreation; area 2742 square metres, being Crown Allotment 2036, Township of Frankston, Parish of Frankston as shown on Original Plan No. OP125099 lodged in the Central Plan Office. – File ref: 1204980

MUNICIPAL DISTRICT OF THE CARDINIA SHIRE COUNCIL

GEMBROOK – Public purposes; being Crown Allotments 2015 [area 9175 square metres, more or less] and 73G [area 2.2 hectares, more or less], Parish of Gembrook of as shown hatched on plan LEGL./20-049 lodged in the Central Plan Office. – File ref: 1201856

MUNICIPAL DISTRICT OF THE BRIMBANK CITY COUNCIL

KEILOR – Cemetery and Crematoria purposes; area 880 square metres, being Crown Allotment 2013, Township of Keilor, Parish of Dousta Galla as shown on Original Plan No. OP124835 lodged in the Central Plan Office. – File ref: 1205425

MUNICIPAL DISTRICT OF THE CAMPASPE SHIRE COUNCIL

ROCHESTER – Public purposes; area 628 square metres, being Crown Allotment 11B, Section 6A, Township of Rochester, Parish of Rochester West as shown on Original Plan No. OP121364 lodged in the Central Plan Office. – File Ref: 2011553

This Order comes into effect on the date it is published in the Government Gazette.

Dated 15 September 2020

Responsible Minister

HON LILY D'AMBROSIO MP

Minister for Energy, Environment and Climate Change

CLAIRE CHISHOLM
Clerk of the Executive Council

Crown Land (Reserves) Act 1978

AMENDMENT OF PERMANENT AND TEMPORARY RESERVATIONS – TOOLANGI

Order in Council

The Governor in Council under section 4(1) of the **Crown Land (Reserves) Act 1978** amends the following Orders in Council:–

TOOLANGI – The Order in Council made on 23 August, 1988 and published in the Government Gazette of 31 August, 1988 – page 2627 of the permanent reservation of Crown Allotments 42 (area of 12.78 hectares) and 43 (area of 19 hectares, more or less), Township of Toolangi, Parish of Tarrawarra North, as a site for ‘Conservation of an area of natural interest’; ...and

TOOLANGI – The Order in Council made on 19 October, 2010 and published in the Government Gazette of 21 October, 2010 – page 2567 of the temporary reservation of Crown Allotment 2002, Township of Toolangi, Parish of Tarrawarra North (area of 9979 square metres) as a site for ‘Conservation of an area of natural interest’

...by adding the words ‘and Tourism and Education’ to the existing reservation purpose of ‘Conservation of an area of natural interest’.

– File Ref: Rs 11036 [0903061]

This Order is effective from the date it is published in the Government Gazette.

Dated 15 September 2020

Responsible Minister

HON LILY D'AMBROSIO MP

Minister for Energy, Environment and Climate Change

CLAIRE CHISHOLM
Clerk of the Executive Council

Road Safety Act 1986

APPROVAL OF A PROPERLY QUALIFIED ANALYST

Order in Council

The Governor in Council under sections 57, 57A and 57B of the **Road Safety Act 1986** by this Order approves Steven Stefanovski as a properly qualified analyst for the purposes of sections 57, 57A and 57B of that Act.

This Order is effective from the date it is published in the Government Gazette.

Dated 15 September 2020

Responsible Minister:

HON BEN CARROLL MP

Minister for Roads and Road Safety

CLAIRE CHISHOLM
Clerk of the Executive Council

PRICING FOR SPECIAL GAZETTE, PERIODICAL GAZETTE AND VICTORIAN LEGISLATION

Retail price varies according to the number of pages in each Victoria Government Special Gazette, Victoria Government Periodical Gazette and Victorian legislation. The table below sets out the prices that apply.

<i>Price Code</i>	<i>No. of Pages (Including cover and blank pages)</i>	<i>Price*</i>
A	1–16	\$4.22
B	17–32	\$6.33
C	33–48	\$8.65
D	49–96	\$13.61
E	97–144	\$17.51
F	145–192	\$20.78
G	193–240	\$23.95
H	241–288	\$25.43
I	289–352	\$28.70
J	353–416	\$33.44
K	417–480	\$38.19
L	481–544	\$44.52
M	545–608	\$50.90
N	609–672	\$56.28
O	673–736	\$63.62
P	737–800	\$70.10
#Q	821–886	\$76.22
#R	887–950	\$81.29
#S	951–1016	\$86.83
#T	1017–1080	\$92.21
#U	1081–1146	\$97.75
#V	1147–1210	\$103.50
#W	1211–1276	\$108.88
#X	1277–1340	\$114.78
#Y	1341–1406	\$119.95

<i>Price Code</i>	<i>No. of Pages (Including cover and blank pages)</i>	<i>Price*</i>
#Z	1407–1470	\$125.60
#ZA	1471–1536	\$131.56
#ZB	1537–1610	\$136.57
#ZC	1611–1666	\$142.32
#ZD	1667–1730	\$147.70
#ZE	1731–1796	\$153.66
#ZF	1797–1860	\$159.20
#ZG	1861–1926	\$164.42
#ZH	1927–1990	\$170.38
#ZI	1991–2056	\$175.76

* All prices include GST

Printed as two volumes

ive

The *Victoria Government Gazette* is published by IVE Group Limited with the authority of the Government Printer for the State of Victoria

© State of Victoria 2020

This publication is copyright. No part may be reproduced by any process except in accordance with the provisions of the Copyright Act.

Address all enquiries to the Government Printer for the State of Victoria

Level 2, 1 Macarthur Street

Melbourne 3002

Victoria Australia

How To Order



**Retail &
Mail Sales**

Victoria Government Gazette

Ground Floor, Building 8,
658 Church Street,
Richmond 3121

DX 106 Melbourne



Telephone

(03) 8523 4601



Fax

(03) 9600 0478

email

gazette@ivegroup.com.au

Recommended Retail Price \$2.30 (includes GST)