



Victoria Government Gazette

By Authority of Victorian Government Printer

No. G 40 Thursday 7 October 2021

www.gazette.vic.gov.au

GENERAL

TABLE OF PROVISIONS

Private Advertisements		Government and Outer Budget Sector	
		Agencies Notices	2093
Estates of Deceased Persons		Obtainables	2122
Aitken Partners	2088		
Arthur J. Dines & Co.	2088		
Australian Unity Trustees			
Legal Services	2088		
Ball + Partners	2088		
Beaumaris Law	2088		
Costanzo Lawyers	2089		
Cumberbatch & Williams Lawyers	2089		
David Davis & Associates	2089		
F. W. Ruddle	2089		
G. & G. Legal	2089		
J. A. Middlemis	2090		
Joliman Lawyers	2090		
KCL Law	2090		
KHQ Lawyers	2090		
Kingston Lawyers Pty Ltd	2091		
McKean Park	2091		
McNab McNab & Starke	2091		
Melling Legal	2091		
O'Halloran Davis	2091		
R B Legal Pty Ltd	2092		
Rennick & Gaynor	2092		
Richard Green	2092		
Sharon Mary Bunn	2092		
Tivey & Holland	2092		

Advertisers Please Note

As from 7 October 2021

The last Special Gazette was No. 551 dated 6 October 2021.

The last Periodical Gazette was No. 1 dated 9 June 2021.

How To Submit Copy

- See our webpage www.gazette.vic.gov.au
 - or contact our office on 8523 4601
between 8.30 am and 5.30 pm Monday to Friday
-

**PUBLICATION OF THE VICTORIA GOVERNMENT GAZETTE (General)
MELBOURNE CUP HOLIDAY WEEK 2021**

Please Note New Deadlines for General Gazette G44/21:

The Victoria Government Gazette (General) for Melbourne Cup week (G44/21) will be published on **Thursday 4 November 2021**.

Copy Deadlines:

Private Advertisements	9.30 am on Friday 29 October 2021
Government and Outer Budget Sector Agencies Notices	9.30 am on Friday 29 October 2021

Office Hours:

The Victoria Government Gazette Office is open during normal office hours over the holiday period, i.e. 8.30 am to 5.30 pm Monday to Friday, excluding public holidays.

Where urgent gazettal is required after hours, arrangements should be made with the Government Gazette Officer on 0419 327 321.

KIM BURNESSE
Government Gazette Officer

PRIVATE ADVERTISEMENTS

Creditors, next-of-kin and others having claims in respect of the estate of EDITH PATRICIA HOCKING, deceased, late of 315, 45 Banool Road, Balwyn, Victoria, retired, who died on 26 July 2021, are requested to send particulars of their claims to the executors, Robert Andrew Bradley and Perpetual Trustee Company Limited, ACN 000 001 007, in the Will called Perpetual Trustees Victoria Limited, ACN 004 027 258, care of the undersigned solicitors, by 10 December 2021, after which date they will convey or distribute the assets, having regard only to the claims of which they then have notice.

AITKEN PARTNERS, solicitors,
Level 28, 140 William Street, Melbourne 3000.

DIMKO TRPESKI, late of 31 Percival Street, Preston, in the State of Victoria, ICT technician, deceased.

Creditors, next-of-kin and others having claims in respect of the estate of the deceased, who died on 24 January 2021, are required by the administrator, Stojan Trpeski, care of Arthur J. Dines & Co., solicitors, 2 Enterprise Drive, Bundoora, in the said State, to send particulars to him by 6 December 2021, after which date the administrator may convey or distribute the assets, having regards only to claims to which he has notice.

Dated 30 September 2021

ARTHUR J. DINES & CO., solicitors,
2 Enterprise Drive, Bundoora 3083.

RAYMOND GORDON SHARPE, late of Castlemaine Health, 142 Cornish Street, Castlemaine, Victoria, deceased.

Creditors, next-of-kin and others having claims in respect of the estate of the deceased, who died on 30 January 2021, are required by Australian Unity Trustees Limited, ACN 162 061 556, of 15/271 Spring Street, Melbourne, Victoria, having been duly authorised by the administrator, Denise Maria Smith, to send particulars to it by 7 January 2022, after which date it may convey or distribute the assets, having regard only to the claims of which it then has notice.

AUSTRALIAN UNITY TRUSTEES
LEGAL SERVICES,
15/271 Spring Street, Melbourne, Victoria 3000.

WILLIAM THOMSON, late of 31 Blackburn Road, Doncaster East, Victoria 3104, deceased.

Creditors, next-of-kin and others having claims in respect of the estate of the deceased, who died on 21 March 2021, are required by Australian Unity Trustees Limited, ACN 162 061 556, of 15/271 Spring Street, Melbourne, Victoria, having been duly authorised by the administrator, James Opie, to send particulars to it by 7 January 2022, after which date it may convey or distribute the assets, having regard only to the claims of which it then has notice.

AUSTRALIAN UNITY TRUSTEES
LEGAL SERVICES,
15/271 Spring Street, Melbourne, Victoria 3000.

LAURIS ALISON TRIBE, late of Unit 2, 12 Stanley Street, Brighton, Victoria 3186, Australia, retired.

Creditors, next-of-kin and others having claims in respect of the estate of the deceased, who died on 18 May 2021, are required by the executor, Robyn Kathleen Napolitano, to send particulars of such claim to her, care of the undermentioned solicitors, by 15 December 2021, after which date she may convey or distribute the assets, having regard only to the claims of which she then has notice.

BALL + PARTNERS, solicitors,
Level 36, 360 Elizabeth Street, Melbourne,
Victoria 3000.

Re: The estate of GEORGETTA OKKAS, late of 13 Mariemont Avenue, Beaumaris, Victoria.

Creditors, next-of-kin and others having claims in respect of the estate of the deceased, who died on 30 December 2020, are required by the executor, Marika Julieana Teresa Okkas, to send particulars to her, care of the undersigned solicitors, by a date not later than two months from the date of publication hereof, after which date the trustee may convey or distribute the assets, having regard only to the claims of which the trustee then has notice.

BEAUMARIS LAW, legal practitioners,
6/1 North Concourse, Beaumaris 3193.

MARIO PERRI, late of 17 Clive Road, Hawthorn East, Victoria, factory worker, deceased.

Creditors, next-of-kin and others having claims in respect of the estate of the abovenamed deceased, who died on 10 November 2020, are required by the executors, Caterina Spataro, Franceschina Bremner, Francesco Perri and Ottavio Perri, care of Suite 2, 261–265 Blackburn Road, Doncaster East, Victoria 3109, to send particulars of their claims to them within 60 days of the date of this notice, after which date the executors may convey or distribute the assets of the estate, having regard only to the claims of which they then have notice. Probate was granted in Victoria on 26 March 2021.

COSTANZO LAWYERS,
Suite 2, 261–265 Blackburn Road,
Doncaster East, Victoria 3109.
Ph: 03 9894 5888.

Re: DOREEN PAMELA HOBBS, late of 42 Olive Road, Lynbrook, Victoria, retired, deceased.

Creditors, next-of-kin and others having claims in respect of the estate of the deceased, who died on 7 April 2021, are required to send particulars of their claims to the executor, Philip Brown, care of the undermentioned solicitors, on or before 7 December 2021, after which date the executor will distribute the assets, having regard only to the claims of which he then has notice.

CUMBERBATCH & WILLIAMS LAWYERS,
37 Martin Place, Glen Waverley, Victoria 3150.

PATRICIA HELEN AUSTIN, late of 145 Studley Road, Heidelberg, Victoria, community worker, deceased.

Creditors, next-of-kin and others having claims in respect of the estate of the deceased, who died on 19 June 2021, are required by the executor, Equity Trustees Wealth Services Limited, ACN 006 132 332, of Level 1, 575 Bourke Street, Melbourne, Victoria, to send particulars to it by 7 December 2021, after which date it may convey or distribute the assets, having regard only to the claims of which it then has notice.

DAVID DAVIS & ASSOCIATES,
Suite 2, 733 High Street, Thornbury,
Victoria 3071.

NORMA FRANCES ROBERTSON, late of House 3, Eureka Village Hostel, 16–40 Balmoral House, Ballarat East, Victoria, housekeeper, deceased.

Creditors, next-of-kin and others having claims in respect of the estate of the deceased, who died on 26 July 2021, are required by the executor, Equity Trustees Wealth Services Limited, ACN 006 132 332, of Level 1, 575 Bourke Street, Melbourne, Victoria, to send particulars to it by 7 December 2021, after which date it may convey or distribute the assets, having regard only to the claims of which it then has notice.

DAVID DAVIS & ASSOCIATES,
Suite 2, 733 High Street, Thornbury,
Victoria 3071.

CHRISTINE HELEN SCREECHE-
POWELL, late of 67 Noble Street, Noble Park,
Victoria, home duties, deceased.

Creditors, next-of-kin and others having claims in respect of the estate of the deceased, who died on 27 May 2021, are required by the executor, Equity Trustees Wealth Services Limited, ACN 006 132 332, of Level 1, 575 Bourke Street, Melbourne, Victoria, to send particulars to it by 7 December 2021, after which date it may convey or distribute the assets, having regard only to the claims of which it then has notice.

DAVID DAVIS & ASSOCIATES,
Suite 2, 733 High Street, Thornbury,
Victoria 3071.

Re: MICHAEL JAMES RUDDLE, late of 105 Hotham Street, East Melbourne, Victoria.

Creditors, next-of-kin and others having claims in respect of the estate of the deceased, who died on 20 March 2021, are required to send particulars of their claims to the executor, F. W. Ruddle, 2A Elgin Avenue, Armadale, Victoria 3143, by 6 December 2021, after which date the executor may convey or distribute the assets, having regard only to the claims of which they may then have notice.

Re: Estate of KERRY MAY CARLESS, late of 25 Beechville Place, Craigieburn, Victoria, pensioner, deceased.

Creditors, next-of-kin and others having claims in respect of the estate of the abovenamed

deceased, who died on 5 November 2020, are required by the executors, Kristen Elizabeth Marshall and Garry John Marshall, to send particulars of their claim to them, care of the undermentioned legal practitioners, by 8 December 2021, after which the executors will distribute the assets of the deceased, having regard only to the claims of which they then have notice.

G. & G. LEGAL, legal practitioners,
80A O'Shanassy Street, PO Box 489,
Sunbury 3429.

Re: Estate of REX WILLIAM KINGHAM, late of Riddell Gardens Aged Care, 10 Spavin Drive, Sunbury, Victoria, retired, deceased.

Creditors, next-of-kin and others having claims in respect of the estate of the abovenamed deceased, who died on 31 January 2020, are required by the executrix, Joanne Elizabeth Brownscombe, to send particulars of their claim to her, care of the undermentioned legal practitioners, by 8 December 2021, after which the executrix will distribute the assets of the deceased, having regard only to the claims of which she then has notice.

G. & G. LEGAL, legal practitioners,
80A O'Shanassy Street, PO Box 489,
Sunbury 3429.

PATRICK NOEL CULLEN, late of 21 Garlepp Road, Welshmans Reef, Victoria, building surveyor, deceased.

Creditors, next-of-kin and others having claims in respect of the estate of the abovenamed deceased, who died on 14 May 2021, are required by Miranda Joy Sherren, the executor of the Will of the deceased, to send particulars of their claims to her, care of the undermentioned address, by 8 December 2021, after which date the executor may convey or distribute the assets, having regard only to the claims of which she then has notice.

J. A. MIDDLEMIS, barrister and solicitor,
30 Myers Street, Bendigo, Victoria 3550.

Re: Estate of MEIRIONA BRAMBLE, deceased.

Creditors, next-of-kin or others having claims in respect of the estate of MEIRIONA BRAMBLE, late of Hope Aged Care, 39 Acacia Street, Swan Hill, in the State

of Victoria, retired, deceased, who died on 8 August 2021, are to send particulars of their claim to the executors, care of the undermentioned legal practitioners, by 24 December 2021, after which the executor will distribute the assets, having regard only to the claims of which he then has notice.

JOLIMAN LAWYERS,
42 McCallum Street, Swan Hill, Victoria 3585.

FIONA ELIZABETH DANIHER, late of 212/110 Roberts Street, West Footscray, Victoria, executive assistant, deceased.

Creditors, next-of-kin and all others having claims in respect of the estate of the deceased, who died on 5 July 2021, are required by the administrator, Edna Josephine Daniher, to send particulars of such claims to the administrator, care of the undermentioned solicitors, within 60 days from the publication hereof, after which date the administrator will distribute the assets, having regard only to the claims of which the administrator has notice.

KCL LAW,
Level 4, 555 Lonsdale Street, Melbourne 3000.

Re: BRUCE DESMOND ANDREWS, late of 2 Tamar Street, Bayswater, Victoria, deceased.

Creditors, next-of-kin and others having claims in respect of the estate of the deceased, who died on 8 March 2013, are required by the trustee, Ines Kallweit of Level 4, 600 Bourke Street, Melbourne, Victoria, to send particulars to the trustee, care of the undermentioned solicitors, by 10 December 2021, after which date the trustee may convey or distribute the assets, having regard only to the claims of which the trustee then has notice.

KHQ LAWYERS,
Level 4, 600 Bourke Street, Melbourne,
Victoria 3000.

Re: ELIZABETH MARY MOORE, late of Pigatto Close, Kyabram, Victoria, deceased.

Creditors, next-of-kin and others having claims in respect of the estate of the deceased, who died on 17 November 2015, are required by the trustee, Ines Kallweit, of Level 4, 600 Bourke Street, Melbourne, Victoria, to send particulars to the trustee, care of the undermentioned solicitors, by 10 December 2021, after which date the trustee

may convey or distribute the assets, having regard only to the claims of which the trustee then has notice.

KHQ LAWYERS,
Level 4, 600 Bourke Street, Melbourne,
Victoria 3000.

Re: IRENA RYTTERBAND (also known as Irene Rytterband), late of 18–22 Fernhill Road, Sandringham, Victoria, retired, deceased.

Creditors, next-of-kin and others having claims in the respect of the estate of Irena Rytterband, deceased, who died on 25 July 2021, are required by the trustee, Hana Rytterband, to send particulars of their claim to the undermentioned firm, by a date not later than two months from the date of publication hereof, after which date the trustee will convey or distribute assets, having regard only to the claims of which she then has notice.

KINGSTON LAWYERS PTY LTD,
barristers and solicitors,
8 Station Road, Cheltenham, Victoria 3192.

Re: MARGARETANNE MacGREGOR, late of Cumberland View Aged Care, 101 Whalley Drive, Wheelers Hill, Victoria, deceased.

Creditors, next-of-kin and others having claims in respect of the estate of the deceased, who died on 15 July 2021, are required by the trustee, Mark Andrew Flynn, care of Level 11, 575 Bourke Street, Melbourne, Victoria, to send particulars to the trustee, care of the undermentioned solicitors, by 21 December 2021, after which date the trustee may convey or distribute the assets, having regard only to the claims of which the trustee then has notice.

McKEAN PARK, lawyers,
Level 11, 575 Bourke Street, Melbourne,
Victoria 3000.

Re: ARTHUR MALCOLM MORRIS, late of New Fairholme, Shrewsbury Road, Oswestry, Shropshire, United Kingdom, deceased.

Creditors, next-of-kin and others having claims in respect of the estate of the deceased, who died on 29 December 2020, are required by the trustee, Christine Serena Cherry Myddelton, care of Level 11, 575 Bourke Street, Melbourne, Victoria, to send particulars to the trustee, care of the undermentioned solicitors, by 21 December 2021, after which date the trustee

may convey or distribute the assets, having regard only to the claims of which the trustee then has notice.

McKEAN PARK, lawyers,
Level 11, 575 Bourke Street, Melbourne,
Victoria 3000.

JEAN JOY CHRISTENSEN, late of 2 Seymour Grove, Brighton, in the State of Victoria, retired, deceased.

Creditors, next-of-kin and others having claims in respect of the estate of the abovenamed deceased, who died at Richmond, Victoria on 5 March 2020, are required by Graeme Robert Smith, the executor and trustee of the estate of the said named deceased, to send particulars of their claims to him, care of McNab McNab & Starke, Level 10, 552 Lonsdale Street, Melbourne, Victoria 3000, by 7 December 2021, after which date he may convey or distribute the assets of the estate, having regard only to the claims of which he then has notice.

McNAB McNAB & STARKE,
Level 10, 552 Lonsdale Street, Melbourne,
Victoria 3000.
Ph: 03 9670 9691.
Ref: KK:200240.

DORIS LILIAN CORBETT, late of 27 Shierlaw Avenue, Canterbury, Victoria, deceased.

Creditors, next-of-kin and others having claims in respect of the estate of the deceased, who died on 1 May 2021, are required by the administrators to send particulars of their claims to them, care of the undermentioned solicitors, within two months from the date of publication of this notice, after which the administrators may convey or distribute the assets, having regard only to the claims of which they then have notice.

MELLING LEGAL,
1/486 Lower Heidelberg Road, Heidelberg,
Victoria 3084.

WILLIAM FRANCIS JOHN ADAMS, deceased, late of Latrobe Valley Village, 5 Ollerton Avenue, Newborough, Victoria.

Creditors, next-of-kin and others having a claim in respect of the estate of the deceased, who died on 7 August 2021, are required to send written particulars of their claim to the executors,

care of PO Box 104, Moe, Victoria 3825, within 60 days from the date of publication of this notice, after which date the executors may convey or distribute the assets, having regard only to the claims of which they may then have notice of.

O'HALLORAN DAVIS, solicitors,
12–14 Kirk Street, Moe 3825.

Re: KAREN ANN JACKOMOS, late of 12 Zest Road, Craigieburn, Victoria 3064.

Creditors, next-of-kin and others having claims in respect of the estate of the deceased, who died on 19 June 2020, are required by the trustee, Jason Leigh Jackomos, care of his solicitors below, to send particulars to the trustee by 6 December 2021, after which date the trustee may convey or distribute the assets, having regard only to the claims of which he then has notice.

R B LEGAL PTY LTD,
Level 3, 250 Queen Street, Melbourne,
Victoria 3000.
Tel: 03 9101 1200, email: charles@rbl.com.au

Re: KATHLEEN SIM, late of 91 Sunny Creek Road, Trafalgar, Victoria 3824, retired, deceased.

Creditors, next-of-kin and others having claims in respect of the estate of the abovenamed deceased, who died on 9 November 2020, are required by the executors, Lynette Christine Gibbs, Rachelle McMillan and Daniel Leslie Minogue, to send particulars of their claims to them, care of the undermentioned solicitors, by 7 December 2021, after which date they may convey or distribute the assets, having regard only to the claims of which they then have notice.

RENNICK & GAYNOR, solicitors,
431 Riversdale Road, Hawthorn East,
Victoria 3123. Ref: NMN: 201990.

Re: NOEL SIDNEY JAMES TOMLINSON, late of 26 Tibrockney Street, Highett, Victoria, retired, deceased.

Creditors, next-of-kin and others having claims in respect of the estate of the abovenamed deceased, who died on 3 March 2021, are required by the executors, Corinne Maria Clark and Nicholas Williams Tomlinson, to send particulars of their claims to them, care of the undermentioned solicitors, by 7 December 2021,

after which date they may convey or distribute the assets, having regard only to the claims of which they then have notice.

RENNICK & GAYNOR, solicitors,
431 Riversdale Road, Hawthorn East,
Victoria 3123.
Telephone: 03 9861 7779. Ref: AE:212445.

Re: The estate of RANDALL MYLES GREEN, formerly of 27 Carlsberg Road, Eaglemont, Victoria 3084.

Creditors, next-of-kin and others having claims in respect of the estate of the deceased, who died on 7 July 1994, are required by the surviving executor, Richard Randall Green, to send particulars to him, care of the undersigned, by 30 October 2021, after which date the trustee may convey or distribute the assets, having regard only to the claims of which the trustee then has notice.

RICHARD GREEN,
PO Box 1265, Hawksburn, Victoria 3142.

MAVIS JOYCE POLLARD, late of 1/6 Devenish Avenue, Montrose, Victoria.

Creditors, next-of-kin and others having claims in respect of the estate of the deceased, who died on 29 May 2021, are required by the trustee, Sharon Mary Bunn, care of 301 Maroondah Highway, Healesville, Victoria 3777, to send particulars to the trustee by 5 November 2021, after which date the trustee may distribute the assets, having regard only to the claims of which she then has notice.

KERRY BERNADETTE KILPATRICK, late of Unit 2, 14 Viewpoint Street, Ararat, Victoria, retired nurse, deceased.

Creditors, next-of-kin and others having claims in respect of the estate of the deceased, who died on 14 February 2021, are required by the executors, Robert Peter Kilpatrick and Fiona Nicole Kilpatrick, care of the undermentioned solicitors, to send particulars to them by 26 November 2021, after which date the executors may convey or distribute the assets, having regard only to the claims of which they then have notice.

TIVEY & HOLLAND, solicitors,
97 Barkly Street, Ararat 3377.

**GOVERNMENT AND OUTER BUDGET
SECTOR AGENCIES NOTICES**



ROAD DISCONTINUATION

Alexandra Street, Eaglehawk and Part of Turner Street, Eaglehawk

Pursuant to section 206 and Schedule 10, Clause 3 of the **Local Government Act 1989**, Greater Bendigo City Council, at its ordinary meeting held on 20 September 2021, resolved to discontinue Alexandra Street, Eaglehawk, described as CA224D Section M at Eaglehawk Parish of Sandhurst and approximately 300 m² of Turner Street, Eaglehawk, adjoining CA224D being Government Road shown hatched on the plan below as not reasonably required as a road for public use. The land is to be transferred to the Department of Environment, Land, Water and Planning to become unreserved Crown Land.

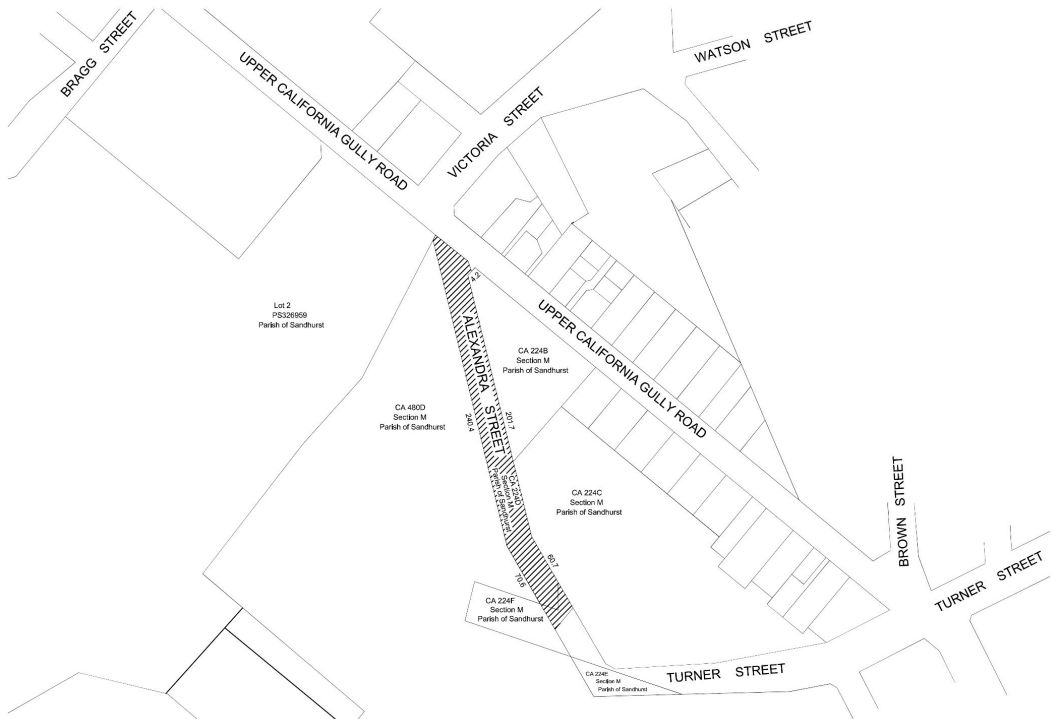

CRAIG NIEMANN
Chief Executive Officer



DECLARATION OF ROAD OVER COUNCIL LAND

Pursuant to section 11(1)(a) of the **Road Management Act 2004** Brimbank City Council hereby declares the land acquired by Council, being part of R1 on LP 6033 as shown hatched on the plan below, to be a road.

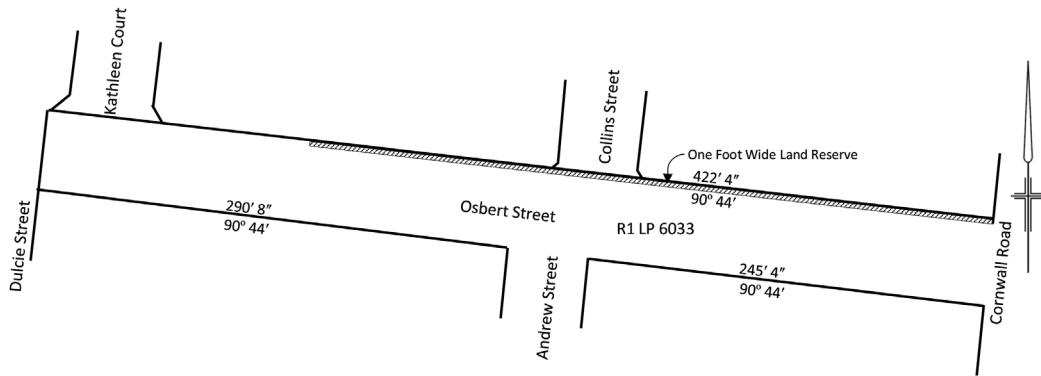

ADRIAN ASHFORD
Manager Engineering Services
Brimbank City Council



CITY OF MELBOURNE

ROAD DISCONTINUANCE

Pursuant to section 206(1) and Clause 3 of Schedule 10 of the **Local Government Act 1989**, the Melbourne City Council (Council) declares the portion of road, shown hatched on the plan hereunder, discontinued. The Council intends to sell the resulting land to the adjoining owner.

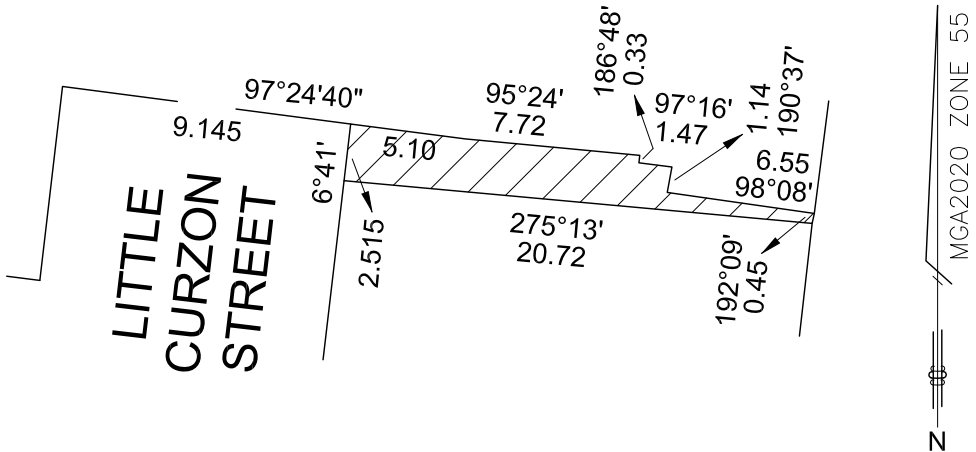

Refer to PS900699J for survey information



GLEN EIRA
CITY COUNCIL

INCLUSION OF TREES IN THE CLASSIFIED TREE REGISTER

On 23 September 2021, under subclause 16(1)(a) of the Glen Eira City Council Classified Tree Local Law (Local Law), Glen Eira City Council resolved to include the trees listed in each item to the Schedule to this notice, nominated under subclause 11(1) of the Local Law, in the Classified Tree Register.

Schedule

Item	Tree	Location
1.	River Red Gum 1 of 2 (<i>Eucalyptus camaldulensis</i>)	Brighton General Cemetery, 261 North Road, Caulfield South
2.	River Red Gum 2 of 2 (<i>Eucalyptus camaldulensis</i>)	Brighton General Cemetery, 261 North Road, Caulfield South
3.	Lilly Pilly (<i>Syzygium smithii</i>)	21 Mitchell Road, Caulfield North
4.	Lemon Scented Gum (<i>Corymbia citriodora</i>)	Corner of Elizabeth Street and Sinclair Street, Elsternwick
5.	River Red Gum (<i>Eucalyptus camaldulensis</i>)	Greenmeadows Garden, St Kilda East
6.	Spotted Gum (<i>Corymbia maculata</i>)	173 Murrumbeena Road, Murrumbeena
7.	Candlebark (<i>Eucalyptus rubida</i>)	Centenary Park, Bignell Road, Bentleigh East

CHRISTIAN RENAUD
Authorised Officer



COUNCIL MEETING DATES FOR 2022

City of Casey hereby gives public notice of the approved schedule of Council meeting dates for 2022 as per resolution of Council on 21 September 2021.

Council Meeting Date

*Held in Function Centre, Bunjil Place, at 4 pm

Tuesday 8 February 2022

Tuesday 8 March 2022

Tuesday 12 April 2022

Tuesday 10 May 2022

Tuesday 14 June 2022

Tuesday 12 July 2022

Tuesday 9 August 2022

Tuesday 13 September 2022

Tuesday 11 October 2022

Tuesday 8 November 2022

Tuesday 13 December 2022

meeting will be able to be viewed via Council's website, www.monash.vic.gov.au

Anyone wishing to be heard by the Committee in support of their written submission must stipulate that as part of their submission.

Submissions may be sent to the Civic and Governance Coordinator: by mail to Civic and Governance Coordinator, Monash Civic Centre, 293 Springvale Road, Glen Waverley, Victoria 3150; or via email to Nick.Andrianis@monash.vic.gov.au

DR ANDI DIAMOND
Chief Executive Officer

Planning and Environment Act 1987

GOLDEN PLAINS PLANNING SCHEME

Notice of the Preparation of an Amendment

Amendment C91gpla

Golden Plains Shire Council has prepared Amendment C91gpla to the Golden Plains Planning Scheme.

The Amendment applies to various parcels of land throughout the Shire in Inverleigh, Bannockburn, Teesdale, Scarsdale, Smythesdale, Durham Lead, Linton, Enfield, Rokewood, Batesford and Haddon.

The Amendment seeks to correct a number of zoning and overlay anomalies, remove redundant overlays, rezone land for public authorities, improve the clarity/legibility of maps in the Planning Scheme, extend an expiry date for certain local policies, modify zoning and overlay schedules, and remove redundant schedules.

Specifically, the Amendment proposes the following changes:

Zoning

- Rezones Crown Allotment 15F Parish of Carrah from the Farming Zone to the Public Conservation and Resource Zone.
- Rezones Crown Allotment 14D Parish of Carrah from the Public Use Zone 6 to the Public Conservation and Resource Zone.
- Rezones Crown Allotment 19G Cemetery Road, Parish of Carrah from the Farming Zone to the Public Use Zone 4.
- Rezones Crown Allotment 19D Cemetery Road, Parish of Carrah from the Public Use Zone 4 to the Public Park and Recreation Zone.



CITY OF MONASH

CALL FOR SUBMISSIONS

Council's Complaints Policy

On Tuesday 28 September 2021, Council adopted a draft Complaints Policy.

The draft policy may be viewed on Council's website: www.monash.vic.gov.au

Written submissions are invited on the policy and will be received until 5.00 pm, Monday 8 November 2021.

A Committee appointed by Council will meet to consider all submissions received on the Complaints Policy, at 7.00 pm, Tuesday 16 November 2021, at the Monash Civic Centre, 293 Springvale Road, Glen Waverley.

If COVID-19 restrictions are in place, the meeting will be conducted virtually. The

- Rezones PC337580, Cemetery Road, Inverleigh from the Public Use Zone 4 to the Low Density Residential Zone.
- Rezones 24 Burns Street, Bannockburn from the Public Use Zone 2 to the General Residential Zone 1.
- Rezones Crown Allotment 1 section 4 Tannery Road, Scarsdale from the Farming Zone to the Public Conservation and Resource Zone.
- Rezones Crown Allotment 4 section 48 Parish of Clarksdale from the Low Density Residential Zone to the Public Conservation and Resource Zone.
- Rezones part of 55 Heales Street, Smythesdale from the Township Zone to the Public Park and Recreation Zone.
- Rezones part of 105 Doctors Road, Smythesdale, from the Public Conservation and Resource Zone to the Rural Zone.
- Rezones part of 195 South Durham Bridge Road, Durham Lead from the Rural Living Zone to the Rural Activity Zone.
- Rezones part of 288 Flagstaff Ridge Road, Linton from the Farming Zone to the Rural Living Zone.
- Rezones part of 290 Flagstaff Ridge Road, Linton, from the Farming Zone to the Rural Living Zone.
- Rezones the Woodland and Forest Glades Estate within the town of Enfield from the Low Density Residential Zone to the Low Density Residential Zone Schedule 2.
- Deletes the Development Plan Overlay Schedule 6 from various sites in Bannockburn.
- Applies the Design and Development Overlay Schedule 5 to 2846 Midland Highway, 14 Smith Road and 18 Smith Road in Lethbridge.
- Removes the Design and Development Overlay Schedule 7 from 195 South Durham Bridge Road, Durham Lead.
- Removes the Vegetation Protection Overlay Schedule 2 from 195 South Durham Bridge Road, Durham Lead.
- Applies the Design and Development Overlay Schedule 5 to 17 Ford Road, Crown Allotment 2 section 10 Ford Road, and Crown Allotment 3 section 10 McMillan Street in Rokewood.
- Deletes the Restructure Overlay from 15 Taemore Close, Haddon and 34 Taylors Road, Haddon.
- Deletes the Incorporated Plan Overlay Schedule 1 from Dog Rocks Estate, Batesford.
- Deletes the Environmental Significance Overlay Schedule 2 in Bannockburn.
- Applies the Environmental Significance Overlay Schedule 2 in Bannockburn.
- Applies the Environmental Significance Overlay Schedule 2 in Teesdale.

Overlays

- Deletes the Development Plan Overlay Schedule 7 from various sites in Inverleigh.
- Deletes the Development Plan Overlay Schedule 8 from various sites in Inverleigh.
- Applies the Design and Development Overlay Schedule 5 to PC337580, Cemetery Road, Inverleigh.
- Applies the Environmental Audit Overlay to PC337580, Cemetery Road, Inverleigh.
- Deletes the Development Plan Overlay Schedule 3 from various sites in Bannockburn.
- Deletes the Development Plan Overlay Schedule 5 from various sites in Bannockburn.
- Deletes the Development Plan Overlay Schedule 4 from various sites in Bannockburn.
- Creates a new Schedule 2 to the Low Density Residential Zone, which applies to land in the Woodlands and Forest Glades Estate, Enfield.
- Amends Clause 43.01 – Schedule to the Heritage Overlay to add tree controls HO97 – Inverleigh Heritage Precinct to include tree controls at 6 High Street (to protect a Stone Pine – *Pinus Pinea*) and 9b High Street (at rear – to protect an Elm tree – *Ulmus Prosera*).
- Amends Clause 43.01 – Schedule to the Heritage Overlay to amend the address listed for HO8 – Prefabricated Iron Cottage,

Ordinance

24 Weatherboard Road to 24 Riverview Road, Inverleigh.

- Deletes Clause 43.03 – Incorporated Plan Overlay.
- Deletes Clause 43.04 – Development Plan Overlay Schedule 3.
- Deletes Clause 43.04 – Development Plan Overlay Schedule 4.
- Deletes Clause 43.04 – Development Plan Overlay Schedule 5.
- Deletes Clause 43.04 – Development Plan Overlay Schedule 6.
- Deletes Clause 43.04 – Development Plan Overlay Schedule 7.
- Deletes Clause 43.04 – Development Plan Overlay Schedule 8.
- Amends Clause 45.05 – Schedule to the Restructure Overlay.
- Amends Clause 11.01-L to increase the expiry date from three years since the approval of C90gpla to four years.
- Amends Clause 11.03-6L-01 Bannockburn to increase the expiry date from three years since the approval of C90gpla to four years.
- Amends Clause 11.03-6L-02 Gheringhap to increase the expiry date from three years since the approval of C90gpla to four years.
- Amends Clause 11.03-6L-04 Smythesdale to increase the expiry date from three years since the approval of C90gpla to four years.

You may inspect the Amendment, any documents that support the Amendment and the explanatory report about the Amendment, at the following locations: the Department of Environment, Land, Water and Planning website, www.delwp.vic.gov.au/public-inspection and on the Golden Plains Shire Strategic Planning webpage <https://www.goldenplains.vic.gov.au/residents/my-home/planning/strategic-planning>

Any person who may be affected by the Amendment may make a submission to the planning authority about the Amendment. Submissions must be made in writing giving the submitter's name and contact address, clearly stating the grounds on which the Amendment is supported or opposed and indicating what changes (if any) the submitter wishes to make.

Name and contact details of submitters are required for Council to consider submissions and to notify such persons of the opportunity to attend

Council Meetings and any public hearing held to consider submissions. The closing date for submissions is 7 November 2021. A submission must be sent by email to enquiries@gplains.vic.gov.au or by mail to: Attn: Strategic Planning, Golden Plains Shire, PO Box 111, Bannockburn, Victoria 3331.

The planning authority must make a copy of every submission available to inspect, free of charge, for two months after the Amendment comes into operation or lapses.

ERIC BRASILIS
Chief Executive Officer

Planning and Environment Act 1987

HUME PLANNING SCHEME

Notice of the Preparation of an Amendment Amendment C253

The Hume City Council has prepared Amendment C253 to the Hume Planning Scheme.

The Amendment applies to land at 105 Vineyard Road, Sunbury.

The Amendment proposes to rezone the land from an Industrial 3 Zone (INZ3) to a General Residential Zone (GRZ) and apply the Development Plan Overlay – Schedule 32 (DPO32) to the whole of the land.

You may inspect the Amendment (COVID-19 lockdown restrictions observed), any documents that support the Amendment and the explanatory report about the Amendment, free of charge, at: the Hume City Council website at www.participate.hume.vic.gov.au; during office hours, at the office of the planning authority, Hume City Council, 1079 Pascoe Vale Road, Broadmeadows; and at the Department of Environment, Land, Water and Planning website, www.delwp.vic.gov.au/public-inspection

Any person who may be affected by the Amendment may make a submission to the planning authority about the Amendment. Submissions must be made in writing giving the submitter's name and contact address, clearly stating the grounds on which the Amendment is supported or opposed and indicating what changes (if any) the submitter wishes to make.

Name and contact details of submitters are required for Council to consider submissions and to notify such persons of the opportunity to attend Council Meetings and any public

hearing held to consider submissions. The closing date for submissions is 8 November 2021. A submission must be sent to the Hume City Council.

The planning authority must make a copy of every submission available at its office and/or on its website for any person to inspect, free of charge, for two months after the Amendment comes into operation or lapses.

SHEENA FROST
Chief Executive Officer

Planning and Environment Act 1987

MANSFIELD PLANNING SCHEME

Notice of the Preparation of an Amendment Amendment C44

The Mansfield Shire Council has prepared Amendment C44 to the Mansfield Planning Scheme.

The land affected by the Amendment is the Mansfield Station Precinct, described as Crown Allotment 59A, Parish of Mansfield, being located at the western entrance to the Mansfield Township north of the Maroondah Highway, east of Withers Lane and west of Kitchen Street.

The Amendment proposes to implement the Mansfield Station Precinct Activation Project, Master Plan and Implementation Plan, May 2019 by:

- amending Clause 21.09 to include the plan as a reference document to the planning scheme and a new objective and strategic directions for the precinct to provide guidance for the use and development of the land;
- introducing an incorporated document Mansfield Station Precinct into the planning scheme to allow a wider range of uses and developments without the need for a planning permit in the Public Park and Recreation Zone applying to the land.

You may inspect the Amendment, any documents that support the Amendment and the explanatory report about the Amendment, free of charge, at the following locations: during office hours, at the office of the planning authority, Mansfield Shire Council, 33 Highett Street, Mansfield; at the Department of Environment, Land, Water and Planning website, www.delwp.vic.gov.au/public-inspection

Any person who may be affected by the Amendment may make a submission to the planning authority about the Amendment. Submissions must be made in writing giving the submitter's name and contact address, clearly stating the grounds on which the Amendment is supported or opposed and indicating what changes (if any) the submitter wishes to make.

Name and contact details of submitters are required for Council to consider submissions and to notify such persons of the opportunity to attend Council Meetings and any public hearing held to consider submissions. The closing date for submissions is 7 November 2021. A submission must be sent to the Mansfield Shire Council, Private Bag 1000, Mansfield, Victoria 3724.

The planning authority must make a copy of every submission available at its office for any person to inspect, free of charge, for two months after the Amendment comes into operation or lapses.

KAYLENE CONRICK
Chief Executive Officer

Planning and Environment Act 1987

MANSFIELD PLANNING SCHEME

Notice of the Preparation of an Amendment Amendment C50

The Mansfield Shire Council has prepared Amendment C50 to the Mansfield Planning Scheme.

The land affected by the Amendment is various locations in Barjarg, Bonnie Doon, Goughs Bay, Mansfield, Merrijig, Merton, Sawmill Settlement and Tolmie to which the Development Plan Overlay applies.

Amendment C50 proposes to implement the Mansfield Planning Scheme Development Plan Overlay Review, May 2021 by:

- removing the Development Plan Overlay from various sites in the Barjarg, Bonnie Doon, Goughs Bay, Mansfield, Merrijig, Merton, Sawmill Settlement and Tolmie areas;
- revising Schedules 1 (General Residential 1 Zone), 2 (Low Density Residential Zone) and 3 (Rural Living Zone) to the Development Plan Overlay;
- deleting Schedules 4 (Southern side of High Street, Mansfield) and 5 (Mixed Use Zone, Barjarg) to the Development Plan Overlay.

You may inspect the Amendment, any documents that support the Amendment and the explanatory report about the Amendment, free of charge, at the following locations: during office hours, at the office of the planning authority, Mansfield Shire Council, 33 Highett Street, Mansfield; and at the Department of Environment, Land, Water and Planning website, www.delwp.vic.gov.au/public-inspection

Any person who may be affected by the Amendment may make a submission to the planning authority about the Amendment. Submissions must be made in writing giving the submitter's name and contact address, clearly stating the grounds on which the Amendment is supported or opposed and indicating what changes (if any) the submitter wishes to make.

Name and contact details of submitters are required for Council to consider submissions and to notify such persons of the opportunity to attend Council Meetings and any public hearing held to consider submissions. The closing date for submissions is 7 November 2021. A submission must be sent to the Mansfield Shire Council, Private Bag 1000, Mansfield, Victoria 3724.

The planning authority must make a copy of every submission available at its office for any person to inspect, free of charge, for two months after the Amendment comes into operation or lapses.

KAYLENE CONRICK
Chief Executive Officer

Planning and Environment Act 1987

MORELAND PLANNING SCHEME

Notice of the Preparation of an Amendment

Amendment C212more

The Moreland City Council has prepared Amendment C212more to the Moreland Planning Scheme.

The Amendment affects all land in the municipality.

The Amendment proposes to:

- delete Design and Development Overlay Schedule 7 from 1–5 and 2–34 Mary Moodie Way; 2–4 Bill Barry Close; 1–21 and 2–20 Dianella Walkway; 1–3 and 2–4 Edwina Way; 1–45 and 2–40 Gear Street; 1–19 and 2–20 Lomandra Walkway; and 12–20 Miller Street, Brunswick East (formally known as 2 John Street and 12–20 Miller Street);
- delete Design and Development Overlay Schedule 9 from 1–11 and 2–12 Copper Lane;

1–17 and 2–16 Pimbial Court; 1–39 and 2–38 Stonewood Circuit; 2–10 Walter Street; and 3–23, 4–16 and 22 Win-Malee Street, Hadfield;

- include changes to the Municipal Planning Strategy and Planning Policy Framework to give effect to Council adopted strategies and recommendations from the Planning Scheme Review Report 2018;
- introduce 3D Modelling application requirements for the Brunswick Activity Centre and Neighbourhood Activity Centres by amending Design and Development Overlay Schedules 18, 19, 20, 22, 23 and 24;
- correct anomalies by fixing ordinance, mapping and clerical errors, including rezoning of land at 6 McDonald Street, Coburg North;
- rezone land purchased for new parks as part of a Park Close to Home to Public Park and Recreation Zone.

You may inspect the Amendment, any documents that support the Amendment and the explanatory report about the Amendment, free of charge, at the Moreland City Council website at moreland.vic.gov.au/amendment-c212 and at the Department of Environment, Land, Water and Planning website, www.delwp.vic.gov.au/public-inspection

Any person who may be affected by the Amendment may make a submission to the planning authority about the Amendment. Submissions must be made in writing giving the submitter's name and contact address, clearly stating the grounds on which the Amendment is supported or opposed and indicating what changes (if any) the submitter wishes to make.

Name and contact details of submitters are required for Council to consider submissions and to notify such persons of the opportunity to attend Council Meetings and any public hearing held to consider submissions. The closing date for submissions is Friday 5 November 2021. A submission must be sent to: Submission to Amendment C212more Strategic Planning Unit, Moreland City Council Locked Bag 10, Moreland, Victoria 3058; or via email to strategicplanning@moreland.vic.gov.au

The planning authority must make a copy of every submission available at its office and/or on its website for any person to inspect, free of charge, for two months after the Amendment comes into operation or lapses.

PHILLIP PRIEST
Acting Director City Futures

Creditors, next-of-kin and others having claims against the estate of any of the undermentioned deceased persons are required to send particulars of their claims to State Trustees Limited, ABN 68 064 593 148, of 1 McNab Avenue, Footscray, Victoria 3011, the personal representative, on or before 8 December 2021, after which date State Trustees Limited may convey or distribute the assets, having regard only to the claims of which State Trustees Limited then has notice.

BARRETT, Margaret Ann, late of Room 58, Samarinda Lodge, 286 High Street, Ashburton, Victoria 3147, retired, deceased, who died on 26 June 2021.

GIANNAKAKIS, Gregory, late of 3, 46 Camden Street, Balaclava, Victoria 3183, deceased, who died on 24 June 2021.

HAAR, Lynne, late of 29 Beattie Crescent, Morwell, Victoria 3840, deceased, who died on 8 June 2021.

KOZMA, Frank, late of Unit 19, 49 Union Street, Windsor, Victoria 3181, deceased, who died on 25 June 2021.

LY, Ha Nu, late of Chestnut Gardens, 2A Chestnut Road, Doveton, Victoria 3177, deceased, who died on 13 May 2021.

MERRY, John Edward, late of 14 Watson Court, Altona, Victoria 3018, deceased, who died on 9 November 2018. Date of Grant 9 September 2021.

SZCZEPANSKI, Richard, late of Bupa Edithvale, 256 Station Street, Edithvale, Victoria 3196, deceased, who died on 8 August 2020.

Dated 29 September 2021

Creditors, next-of-kin and others having claims against the estate of any of the undermentioned deceased persons are required to send particulars of their claims to State Trustees Limited, ABN 68 064 593 148, of 1 McNab Avenue, Footscray, Victoria 3011, the personal representative, on or before 13 December 2021, after which date State Trustees Limited may convey or distribute the assets, having regard only to the claims of which State Trustees Limited then has notice.

COX, Ian George, late of 82 Hillview Avenue, Mount Waverley, Victoria 3149, deceased, who died on 28 June 2020.

FROST, David Mark, late of Unit 8, 141 Standish Street, Myrtleford, Victoria 3737, deceased, who died on 20 August 2021.

KUCAN, Ivan, late of 6 Greer Street, Footscray, Victoria 3011, deceased, who died on 11 December 2020.

LOCKYEAR, Anthony Malcolm, late of Napier Street Aged Care, 179 Napier Street, South Melbourne, Victoria 3205, deceased, who died on 9 February 2021.

SADLER, Jeffrey Oliver, late of Unit 15, 142 Townsend Road, St Albans Park, Victoria 3219, deceased, who died on 17 August 2021.

STUKENBROCK, Manfred Karl, late of Room 21, Wynalla House, 1 Howard Street, Sebastopol, Victoria 3356, deceased, who died on 8 November 2020.

Dated 4 October 2021

Bus Safety Act 2009

DECLARATION UNDER SECTION 7(1)(c)

I, Lisa Faldon, delegate of the Director, Transport Safety, in exercise of the powers vested in me under section 7(1)(c) of the **Bus Safety Act 2009** hereby declare the following courtesy bus services within the meaning of section 3(1) of the **Bus Safety Act 2009** to be non-commercial courtesy bus services for the purpose of section 3(1) of the **Bus Safety Act 2009**:

Bus Operator Name:	ACN/ARBN:	Registered Address:
Windows Film Productions Pty Ltd	650 586 404	Unit 2, 25 Second Street, Clayton South, Victoria 3169

This declaration is made on the basis that the non-commercial courtesy bus operators specified above:

- (a) have provided evidence that they do not derive any profit from the provision of the bus service; and
- (b) only use the bus service to transport their staff/employees in connection with their trade or business.

This declaration is made following consultation with the affected operators and sectors of the industry as required under section 7(2) of the **Bus Safety Act 2009**.

Dated 15 September 2021

LISA FALDON
Delegate of the Director, Transport Safety
Director, Bus Safety

Electoral Act 2002CHANGE TO REGISTER OF
POLITICAL PARTIES

In accordance with section 51(5)(e) of the **Electoral Act 2002** (the Act), I hereby give notice of the following change to the Register of Political Parties.

Name of registered political party: Democratic Labour Party (DLP)

New registered officer: Michael Palma

New address: 52 Bateman Grove, Hampton Park, Victoria 3976

Dated 4 October 2021

WARWICK GATELY, AM
Victorian Electoral Commission

Emergency Management Act 1986**NOTICE OF DECLARATION AND REVOCATION OF
EMERGENCY AREA (SECTION 36A(7))**

At 6:00 am on 18 September 2021, Assistant Commissioner Luke Cornelius APM, being the most senior Victoria Police officer at or above the rank of Senior Sergeant in attendance at an emergency, made a declaration of an emergency area in relation to the area around the Melbourne Central Business District under section 36A(1) of the **Emergency Management Act 1986**.

The declaration was made on the basis that, in the opinion of the Assistant Commissioner, it was necessary to exclude persons from the area of the emergency due to the significant public health risk posed by a planned protest in or around that area on 18 September 2021, given the transmission risk of COVID-19 at that event. The declaration was necessary to ensure public safety, security of evacuated premises, and the safety of, or prevention of obstruction, hindrance or interference to, persons engaging in emergency activities.

The declared emergency area included all public places within the area bound by and including, the intersection of Olympic Boulevard and Punt Road, to Hoddle Street, to the intersection of Hoddle Street and Victoria Street, to the intersection of Victoria Street and Brunswick Street, to the intersection of Brunswick Street and Gertrude Street, to the intersection of Gertrude Street and Nicholson Street, to the intersection of Nicholson Street to Elgin Street, to the intersection of Elgin Street and Swanston Street, to the intersection of Swanston Street and Grattan Street, to the intersection of Grattan Street and Wreckyn Street, to the intersection of Wreckyn Street, to the intersection of Wreckyn Street and Arden Street, to the intersection of Arden Street to Dryburgh Street, Dryburgh Street and Dynon Road, to the intersection of Dynon Road and Citylink Freeway, to the intersection of Citylink off ramp and Footscray Road, to the intersection of Footscray Road and Dudley Street, to the intersection of Dudley Street and Wurundjeri Way, to the intersection of Wurundjeri Way and Montague Street, to the intersection of Montague Street and York Street, to the intersection of York Street and Ferrars Street, to the intersection of Ferrars Street and Park Street, to the intersection of Park Street and St Kilda Road, to the intersection of Linlithgow Avenue and Olympic Boulevard.

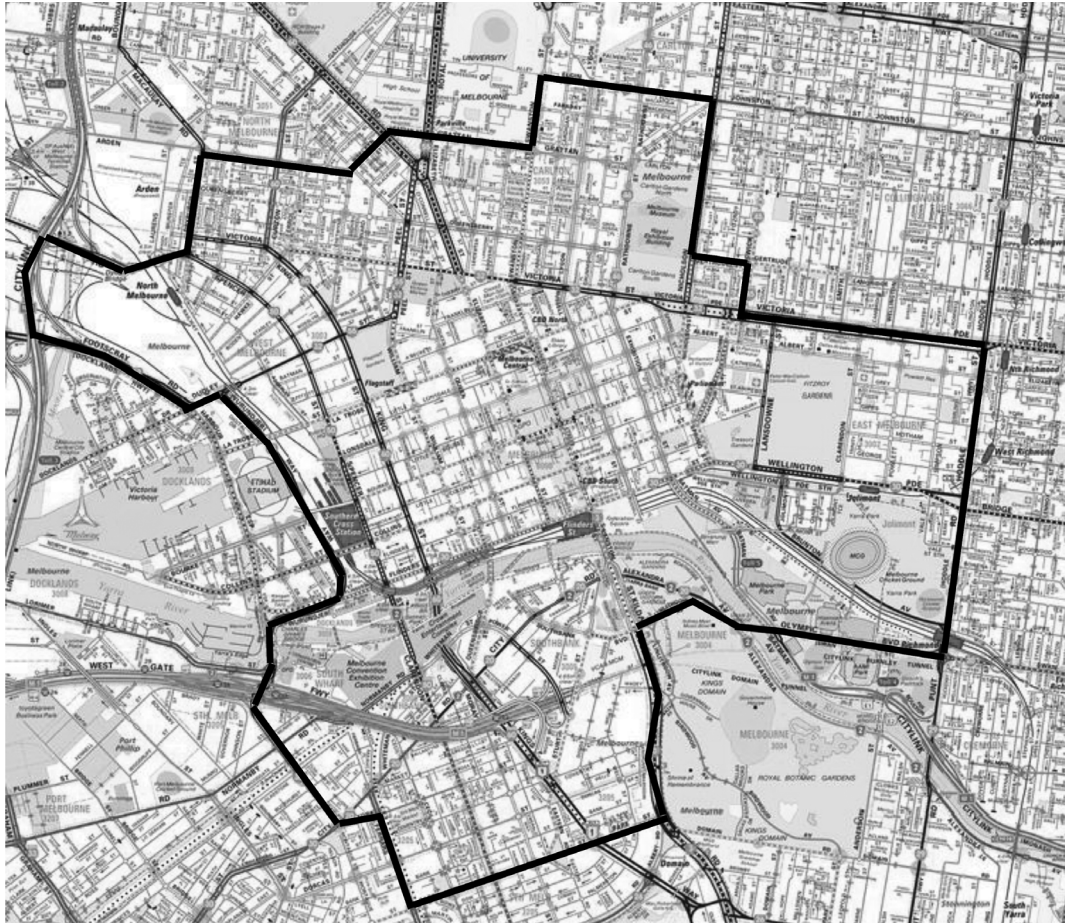
Emergency Declaration Designated Area

The effect of the declaration was to allow Victoria Police officers to exercise powers under section 36B of the **Emergency Management Act 1986**, including preventing and restricting access to the emergency area.

The declaration of the emergency area was revoked by Assistant Commissioner Luke Cornelius APM at 5.24 pm on 18 September 2021 under section 36A(4) of the **Emergency Management Act 1986**.

Dated 27 September 2021

ANDREW CRISP APM
Emergency Management Commissioner

Flora and Fauna Guarantee Act 1988

NOTICE OF DECISION UNDER SECTION 16G

In accordance with section 16G of the **Flora and Fauna Guarantee Act 1988**, Lily D'Ambrosio, Minister for Energy, Environment and Climate Change, and Mary-Anne Thomas, Minister for Agriculture have:

- (i) considered the recommendation of the Scientific Advisory Committee regarding *Plectorrhiza tridentata* (Tangle Orchid) as published on the internet at <https://www.environment.vic.gov.au/conserving-threatened-species/threatened-list> and in the Government Gazette on 29 July 2021; and
- (ii) decided to recommend to the Governor in Council that the taxon described in Column 1 of Table 1 in the Schedule to this Notice be specified in the Threatened List as critically endangered in Victoria for the reasons that it meets the criteria shown in Column 5 of that table.

SCHEDULE

In Table 1 in this Schedule –

3.1 means Criteria 3.1 of the Flora and Fauna Guarantee Regulations 2020 and that the taxon of flora or fauna is critically endangered.

3.1.1 means Sub-criterion 3.1.1 of the Flora and Fauna Guarantee Regulations 2020 and that the taxon has undergone, is suspected to have undergone, or is likely to undergo in the immediate future, a very severe reduction in population size.

Table 1

Column 1 Taxon	Column 2 Common Name	Column 3 Extinction Risk	Column 4 Category of Threat	Column 5 Criteria Satisfied
<i>Plectorrhiza tridentata</i>	Tangle Orchid	Victoria	Critically Endangered	3.1; 3.1.1

Dated 30 August 2021
LILY D'AMBROSIO
Minister for Energy, Environment
and Climate Change

Dated 27 September 2021
MARY-ANNE THOMAS
Minister for Agriculture

Gambling Regulation Act 2003

Section 5.3.19

AMENDMENT OF THE PUBLIC LOTTERY LICENCE

Notice is given that, on 20 September 2021, in accordance with section 5.3.19 of the **Gambling Regulation Act 2003**, I amended the Public Lottery Licence awarded to Tattersall's Sweeps Pty Ltd.

Annexure A of the Public Lottery Licence has been amended to:

- remove the odds of winning range from Clause 2.1(d);
- remove the limit on the number of prize divisions in Clause 2.1(e); and
- make other technical amendments to rectify minor typographical errors and ensure consistency with the lottery rules.

A copy of the amendment is available on the Victorian Commission for Gambling and Liquor Regulation website at: www.vcqlr.vic.gov.au

Dated 20 September 2021

HON. MELISSA HORNE MP
Minister for Consumer Affairs, Gaming and Liquor Regulation

Forests Act 1958**AMENDMENT OF DETERMINATION OF FIREWOOD COLLECTION AREA**

I, Paul Bates, Acting Deputy Chief Fire Officer, Loddon Mallee Region, Department of Environment, Land, Water and Planning, make the following determination under section 57U of the **Forests Act 1958**, amend the determination made under section 57U of the **Forests Act 1958** on 18 August 2021 and published in the Government Gazette No. G 34 page 1837–38 on 26 August 2021 by *substituting* 7/10/2021 for 30/11/2021 in column 6 of items 7 and 13 in the table in the determination.

Item no.	Column 1 LEGL no.	Column 2 DELWP region	Column 3 DELWP district	Column 4 Name of firewood collection area	Column 5 Opening date	Column 6 Closing date
7	20-280	Loddon Mallee	Murray Goldfields	Harper Norman DFW	1/09/2021	7/10/2021
13	21-631	Loddon Mallee	Murray Goldfields	Mount Hooghly – White Tk	1/09/2021	7/10/2021

This amendment comes into operation on 7/10/2021.

Dated 27 September 2021

PAUL BATES

Acting Deputy Chief Fire Officer, Loddon Mallee
Department of Environment, Land, Water and Planning
as delegate of the Secretary to the
Department of Environment, Land, Water and Planning

Geographic Place Names Act 1998**NOTICE OF REGISTRATION OF GEOGRAPHIC NAMES**

The Registrar of Geographic Names hereby gives notice of the registration of the undermentioned place names.

Feature Naming:

Change Request Number	Feature Name	Authority and Location
CR 141743	Mildura Sporting Precinct	Mildura Rural City Council Located at the southern corner of Deakin Avenue and Sixteenth Street, Mildura For further details see map at www.land.vic.gov.au/place-naming
CR 141855	Freshbrook Avenue Park	Wyndham City Council Located at 4 Freshbrook Avenue, Truganina For further details see map at www.land.vic.gov.au/place-naming
CR 141855	Lough Way Park	Wyndham City Council Located at 2 Lough Way, Manor Lakes For further details see map at www.land.vic.gov.au/place-naming
CR 141855	Raffles Walk Park	Wyndham City Council Located at 1 Raffles Walk, Werribee For further details see map at www.land.vic.gov.au/place-naming

–	Wangala Primary School	Department of Education and Training Previously the Oberon South Primary School Located at 45a Kidman Avenue, Belmont For further details see map at www.land.vic.gov.au/place-naming
–	Wurun Senior Campus	Department of Education and Training Located at 111 Queens Parade, Fitzroy North For further details see map at www.land.vic.gov.au/place-naming
–	Niddrie Autistic School	Department of Education and Training Located at the corner of Garnet and Teague Streets, Niddrie For further details see map at www.land.vic.gov.au/place-naming
CR 141778	Durrell Road Park	Wyndham City Council Located at 24 Durrell Road, Truganina For further details see map at www.land.vic.gov.au/place-naming
CR 141778	Gathering Grove Park	Wyndham City Council Located at 2 Gathering Grove, Tarneit For further details see map at www.land.vic.gov.au/place-naming
CR 141778	Brookside Drive Park	Wyndham City Council Located at 1 Brookside Drive, Wyndham Vale For further details see map at www.land.vic.gov.au/place-naming
CR 141778	Stanmore Crescent Park	Wyndham City Council Located at 58 Stanmore Crescent, Wyndham Vale For further details see map at www.land.vic.gov.au/place-naming
CR 141778	Matheson Avenue Park	Wyndham City Council Located at 26 Matheson Avenue, Wyndham Vale For further details see map at www.land.vic.gov.au/place-naming
CR 141778	Broberg Street Park	Wyndham City Council Located at 5 Broberg Street, Wyndham Vale For further details see map at www.land.vic.gov.au/place-naming
CR 141778	Clifton Circuit Park	Wyndham City Council Located at 31 Clifton Circuit, Tarneit For further details see map at www.land.vic.gov.au/place-naming
CR 141778	Congo Drive Park	Wyndham City Council Located at 44 Congo Drive, Tarneit For further details see map at www.land.vic.gov.au/place-naming
CR 141778	Natal Road Park	Wyndham City Council Located at 2 Natal Road, Tarneit For further details see map at www.land.vic.gov.au/place-naming

CR 141778	Tributary Street Park	Wyndham City Council Located at 2 Tributary Street, Tarneit For further details see map at www.land.vic.gov.au/place-naming
CR 141778	Townley Boulevard Park	Wyndham City Council Located at 45 Townley Boulevard, Werribee For further details see map at www.land.vic.gov.au/place-naming
CR 141778	Vestige Circuit Park	Wyndham City Council Located at 33 Vestige Circuit, Tarneit For further details see map at www.land.vic.gov.au/place-naming

Road Naming

Change Request Number	Road Name	Locality	Naming Authority and Location
CR 141938	Ridd Drive	Seymour	Mitchell Shire City Council. Previously known as Ridd Court, the road is accessed off Tarcombe Road
CR 139322	Airport Road	Cobden	Corangamite Shire City Council The road traverses south off Grayland Street
CR 141673	Lovett Court	Maryborough	Goldfields Shire City Council The road traverses south-west off East Field Street

Geographic Names Victoria

Land Use Victoria

2 Lonsdale Street

Melbourne 3000

CRAIG L. SANDY
Registrar of Geographic Names

Health Complaints Act 2016

Section 90

INTERIM PROHIBITION ORDER

This Interim Prohibition Order is made pursuant to section 90 of the **Health Complaints Act 2016**.

The Health Complaints Commissioner (Commissioner) has made this Interim Prohibition Order because the Commissioner reasonably believes that the general health service provider named below has contravened a code of conduct applying to the general health service being provided and is satisfied that it is necessary to make this order to avoid a serious risk to the health, safety or welfare of the public.

Name of the general health service provider on whom the Interim Prohibition Order is imposed:	Robert Loriente of Williamstown in the State of Victoria who also trades as 'Coburg Massage'
Date this Interim Prohibition Order is made:	26 September 2021
Date on which this Interim Prohibition Order expires:	An Interim Prohibition Order can remain in force for up to 12 weeks. This Interim Prohibition Order will remain in force until 18 December 2021 while an investigation is conducted, unless it is revoked before that date.
Effect of this Interim Prohibition Order:	<ol style="list-style-type: none"> 1. The general health service provider named above must not, directly or indirectly: <ul style="list-style-type: none"> ● advertise or cause to be advertised, or ● offer or cause to be offered, or ● provide or cause to be provided, or ● establish, direct or otherwise operate any business that either advertises, offers or provides (or causes to be advertised, offered or provided) any general health service (paid or otherwise, in a clinical or non-clinical capacity) that involves physical contact (including massage services) to any female persons. 2. The general health service provider named above must prominently display a copy of this Interim Prohibition Order at any premises where he provides any general health service and must ensure that it is easily visible to the public. 3. The general health service provider named above must prominently publish a copy of this Interim Prohibition Order on the homepage, in a manner that is easily visible to the public, of any website or social medial platform he uses to offer or promote any general health service.

In this Interim Prohibition Order 'general health service' and 'general health service provider' have the same meaning as in section 3 of the **Health Complaints Act 2016**.

This Interim Prohibition Order takes effect on the service of the order on the general health service provider to whom it applies.

This Order will be published in the Victoria Government Gazette and on the internet site of the Health Complaints Commissioner, www.hcc.vic.gov.au

KAREN CUSACK
Health Complaints Commissioner

Health Complaints Act 2016

Section 90

INTERIM PROHIBITION ORDER

This Interim Prohibition Order is made pursuant to section 90 of the **Health Complaints Act 2016**.

The Health Complaints Commissioner (Commissioner) has made this Interim Prohibition Order because the Commissioner reasonably believes that the general health service provider named below has contravened a code of conduct applying to the general health service being provided and is satisfied that it is necessary to make this order to avoid a serious risk to the health, safety or welfare of the public.

Name of the general health service provider on whom the Interim Prohibition Order is imposed:	Martina Gorner of Chadstone in the State of Victoria
Date this Interim Prohibition Order is made:	29 September 2021
Date on which this Interim Prohibition Order expires:	An Interim Prohibition Order can remain in force for up to 12 weeks. This Interim Prohibition Order will remain in force until 21 December 2021 while an investigation is conducted unless it is revoked before that date.
Effect of this Interim Prohibition Order:	<ol style="list-style-type: none"> 1. The general health service provider named above must not, directly or indirectly: <ol style="list-style-type: none"> a. advertise or cause to be advertised, b. offer or cause to be offered, c. provide or cause to be provided, or d. establish, direct or otherwise operate any business that either advertises, offers or provides (or causes to be advertised, offered or provided) any general health service, paid or otherwise, in a clinical or non-clinical capacity. 2. The general health service provider named above must prominently display a copy of this Interim Prohibition Order at any premises where she provides any general health service and must ensure that it is easily visible to the public. 3. The general health service provider named above must prominently publish a copy of this Interim Prohibition Order on the homepage of any website or social media platform she uses to promote themselves or the supply of any goods or services, including, but not limited to: <ol style="list-style-type: none"> a. https://www.instagram.com/martina_gorner/ b. https://www.instagram.com/confessions_of_a_midwife/

In this Interim Prohibition Order ‘general health service’ and ‘general health service provider’ have the same meaning as in section 3 of the **Health Complaints Act 2016**.

This Interim Prohibition Order takes effect on the service of the order on the general health service provider to whom it applies.

This Order will be published in the Victoria Government Gazette and on the internet site of the Health Complaints Commissioner, www.hcc.vic.gov.au

KAREN CUSACK
Health Complaints Commissioner

Health Complaints Act 2016

Section 90

INTERIM PROHIBITION ORDER

This Interim Prohibition Order is made pursuant to section 90 of the **Health Complaints Act 2016**.

The Health Complaints Commissioner (Commissioner) has made this Interim Prohibition Order because the Commissioner reasonably believes that the general health service provider named below has contravened a code of conduct applying to the general health service being provided and is satisfied that it is necessary to make this order to avoid a serious risk to the health, safety or welfare of the public.

Name of the general health service provider on whom the Interim Prohibition Order is imposed:	Ten Moons Pty Ltd (ACN 164 419 514) registered in Highett in Victoria
Date this Interim Prohibition Order is made:	29 September 2021
Date on which this Interim Prohibition Order expires:	An Interim Prohibition Order can remain in force for up to 12 weeks. This Interim Prohibition Order will remain in force until 21 December 2021 while an investigation is conducted unless it is revoked before that date.
Effect of this Interim Prohibition Order:	<ol style="list-style-type: none"> 1. The general health service provider named above must not: <ol style="list-style-type: none"> a. advertise or cause to be advertised, or b. offer or cause to be offered, or c. provide or cause to be provided any general health service (paid or otherwise, in a clinical or non-clinical capacity). 2. The general health service provider named above must prominently display a copy of this Interim Prohibition Order at any premises where it provides any general health service and must ensure that it is easily visible to the public. 3. The general health service provider named above must prominently publish a copy of this Interim Prohibition Order on the homepage of any website or social media platform it uses to promote itself or the supply of any goods or services.

In this Interim Prohibition Order ‘general health service’ and ‘general health service provider’ have the same meaning as in section 3 of the **Health Complaints Act 2016**.

This Interim Prohibition Order takes effect on the service of the order on the general health service provider to whom it applies.

This Order will be published in the Victoria Government Gazette and on the internet site of the Health Complaints Commissioner, www.hcc.vic.gov.au

KAREN CUSACK
Health Complaints Commissioner

Plant Biosecurity Act 2010**ORDER PROHIBITING OR RESTRICTING THE ENTRY OR IMPORTATION INTO VICTORIA OF MATERIALS WHICH ARE HOSTS OF TOMATO POTATO PSYLLID**

I, Rosa Crnov, as delegate of the Minister for Agriculture, being of the reasonable suspicion that the exotic pest tomato potato psyllid exists within Australia but outside Victoria, make the following Order:

1 Objective

The objective of this Order is to prohibit, restrict or impose conditions upon the entry or importation into Victoria of materials which are hosts of tomato potato psyllid.

2 Authorising provision

This Order is made under section 36(1) of the **Plant Biosecurity Act 2010** (the Act).

3 Commencement

This Order comes into force on the day of making.

4 Revocation

The Order entitled Order prohibiting or restricting the entry or importation into Victoria of materials which are hosts of tomato potato psyllid made under section 36(1) of the **Plant Biosecurity Act 2010**, and published in Victoria Government Gazette G41 on 15 October 2020 at pages 2121–2125 is **revoked**.

5 Definitions

In this Order –

‘**APVMA**’ means the Australian Pesticides and Veterinary Medicines Authority.

‘**Category 1**’ means all plants belonging to the plant families *Convolvulaceae* or *Solanaceae*.

‘**Category 2**’ means all plants belonging to the plant families *Amaranthaceae*, *Asclepiadaceae*, *Asparagaceae*, *Asteraceae*, *Boraginaceae*, *Brassicaceae*, *Caprifoliaceae*, *Chenopodiaceae*, *Cupressaceae*, *Ephedraceae*, *Ericaceae*, *Fabaceae*, *Garryaceae*, *Grossulariaceae*, *Lamiaceae*, *Malvaceae*, *Oleaceae*, *Pinaceae*, *Plantaginaceae*, *Poaceae*, *Polygonaceae*, *Ranunculaceae*, *Rosaceae*, *Salicaceae*, *Sapindaceae*, *Violaceae*, *Vitaceae* or *Zygophyllaceae*.

‘**host material**’ means any host plant, and any agricultural equipment or package used in the cultivation, processing, packaging or transport of any host plant.

‘**host plant**’ means any Category 1 plant, or plant product of such plants, including fruit and vegetables for consumption and cut flowers, but excluding: (i) dried or processed plant products (such as chaff, dried herbs, grain, hay, mulch, seed or timber); or (ii) tubers (including dormant seed, ware and processing potatoes), bulbs, corms and rhizomes without attached green material (e.g. leaves, stem, etc.); and

any Category 2 plant, or plant product of such plants, including fruit and vegetables for consumption and cut flowers, but excluding: (i) dried or processed plant products (such as chaff, dried herbs, grain, hay, mulch, seed or timber); (ii) dormant trees without foliage/fruit; (iii) fresh fruit/vegetables without leaves, calyx or other attached green material; or (iv) tubers, bulbs, corms and rhizomes without attached green material (e.g. leaves, stem etc.).

‘**tomato potato psyllid**’ means the pest *Bactericera cockerelli* (Sulc).

‘**unit**’ means each individual item, such as in the case of fruit, an individual piece of fruit and in the case of plants, an individual plant.

6 Prohibitions, restrictions and conditions

The following prohibitions, restrictions and conditions are specified in relation to the entry or importation of host material.

- (a) The entry or importation into Victoria of any host material is prohibited.
- (b) Sub-clause (a) does not apply if the host material –

- (i) originates from an area for which there is currently in force an area freedom certificate, being a certificate issued by an officer responsible for agriculture in the State or Territory from which the host material originated, certifying that the area from which the host material originated is known to be free of tomato potato psyllid; or
- (ii) is accompanied by a plant health certificate, assurance certificate or plant health declaration, certifying or declaring that the material has been treated in a manner described in the Schedule to this Order; or
- (iii) enters Victoria under and in accordance with a permit issued by an inspector and there is compliance with any conditions or requirements set out in the permit.

7 Verification of consignments

Where requested by an inspector, host material imported into Victoria, which is required by Clause 6(b)(ii) to be accompanied by a certificate or declaration, must be:

- (a) presented to an inspector for inspection; or
- (b) verified by a person accredited to do so by the Department of Jobs, Precincts and Regions.

8 Expiry

This Order remains in force for a period of 12 months from the date of making.

Schedule

Host material must –

- (1) in the case of plants and planting material of Category 1, be –
 - (a) grown on an approved Pest Free Production Site; and
 - (b) packed in a manner that prevents infestation by tomato potato psyllid; or
 - (c) treated with an insecticide effective against all life stages of tomato potato psyllid and registered for the control of tomato potato psyllid at rates specified on the label, or in accordance with an APVMA permit; and
 - (i) packed in a manner that prevents infestation by tomato potato psyllid; and
 - (ii) undergo a 2% or 600 unit inspection and be found free of tomato potato psyllid; or
- (2) in the case of plants and planting material of Category 2, be –
 - (a) treated with one of the following pesticide treatments in accordance with the chemical label or APVMA permit, ensuring the treatment makes contact with the underside of the leaf –
 - (i) abamectin within 3 days prior to dispatch;
 - (A) with 18 g/L active constituent at a rate of 90 mL/100 L or 450 mL/ha, plus 500 mL of Summer Spray Oil, or
 - (B) with 36 g/L active constituent at a rate of 45 mL/100 L or 225 mL/ha, plus 500 mL of Summer Spray Oil, or
 - (ii) bifenthrin within 3 days prior to dispatch;
 - (A) with 100 g/L active constituent at a rate of 80 mL/100 L, or
 - (B) with 250 g/L active constituent at a rate of 32 mL/100 L, or
 - (iii) methomyl within 3 days prior to dispatch, with 225 g/L active constituent at rate of 200 mL/100 L, and;
 - (iv) packed in a manner that prevents infestation by tomato potato psyllid; and
 - (v) undergo a 2% or 600 unit inspection and be found free of tomato potato psyllid; or

- (b) fumigated with 1000 g/kg active constituent methyl bromide at:
 - (i) 10°C – 10.9°C @ 56 g/m³ for 2 hours; or
 - (ii) 11°C – 15.9°C @ 48 g/m³ for 2 hours; or
 - (iii) 16°C – 20.9°C @ 40 g/m³ for 2 hours; or
 - (iv) 21°C – 31.9°C @ 32 g/m³ for 2 hours; and
 - (v) immediately after treatment, the fruit is placed in secure conditions that prevent infestation of tomato potato psyllid, or
- (3) in the case of fruit and vegetables for consumption with leaves, calyx or other attached green material from Category 1, be –
 - (a) treated prior to harvest with an insecticide effective against all life stages of tomato potato psyllid and registered for the control of tomato potato psyllid at rates specified on the label, or in accordance with an APVMA permit; and
 - (i) packed in a manner that prevents infestation by tomato potato psyllid; and
 - (ii) undergo a 600 unit inspection and be found free of tomato potato psyllid; or
 - (b) fumigated with 1000g/kg active constituent methyl bromide at:
 - (i) 10°C – 10.9°C @ 56 g/m³ for 2 hours; or
 - (ii) 11°C – 15.9°C @ 48 g/m³ for 2 hours; or
 - (iii) 16°C – 20.9°C @ 40 g/m³ for 2 hours; or
 - (iv) 21°C – 31.9°C @ 32 g/m³ for 2 hours; and
 - (v) immediately after treatment, the fruit is placed in secure conditions that prevent infestation by tomato potato psyllid; or
- (4) in the case of fruit and vegetables for consumption without leaves, calyx, or other attached green material from Category 1 or fruit and vegetables for consumption with leaves, calyx or other attached green material from Category 2, be –
 - (a) treated prior to harvest with an insecticide effective against all life stages of tomato potato psyllid and registered for the control of tomato potato psyllid at rates specified on the label, or in accordance with an APVMA permit; and
 - (i) packed in a manner that prevents infestation by tomato potato psyllid; and
 - (ii) undergo a 600 unit inspection and be found free of tomato potato psyllid; or
 - (b) fumigated with 1000 g/kg active constituent methyl bromide at:
 - (i) 10°C – 10.9°C @ 56 g/m³ for 2 hours; or
 - (ii) 11°C – 15.9°C @ 48 g/m³ for 2 hours; or
 - (iii) 16°C – 20.9°C @ 40 g/m³ for 2 hours; or
 - (iv) 21°C – 31.9°C @ 32 g/m³ for 2 hours; and
 - (v) immediately after treatment, the fruit is placed in secure conditions that prevent infestation by tomato potato psyllid; or
 - (c) washed, drenched or sprayed in accordance with one of the following methods and following equipment manufacturer’s instructions to effectively remove adult tomato potato psyllid by –
 - (i) hydro-cooling with continuously circulated water for a period of not less than 20 minutes with a minimum flow rate of 200 litres per minute per square metre, or

- (ii) immersion in water with produce remaining submerged for a period of not less than 3 minutes with adequate circulation of the water over and around the produce, or
- (iii) high pressure spray washing by water in a single layer to ensure complete coverage of the produce passing through the spray at pressure of 200 kpa (29 psi) for not less than 20 seconds, or
- (iv) movement in a single layer along roller brushes for at least 30 seconds receiving sprayed water to all surfaces at a minimum of 16 L/min; and
- (v) packed in a manner that prevents infestation by tomato potato psyllid; and
- (vi) undergo a 2% or 600 unit inspection and be found free of tomato potato psyllid; or
- (d) treated with one of the following pesticide treatments in accordance with the chemical label or APVMA permit, ensuring the treatment makes contact with the underside of the leaf –
 - (i) abamectin within 4 days prior to dispatch;
 - (A) with 18 g/L active constituent at a rate of 90 mL/100 L or 450 mL/ha; or
 - (B) with 36 g/L active constituent at a rate of 45 mL/100 L or 225 mL/ha; or
 - (ii) bifenthrin within 4 days prior to dispatch;
 - (A) with 100 g/L active constituent at a rate of 80 mL/100 L; or
 - (B) with 250 g/L active constituent at a rate of 32 mL/100 L; or
 - (iii) methomyl within 4 days prior to dispatch;
 - (A) with 225 g/L active constituent at a rate of 200 mL/100 L; and
 - (iv) packed in a manner that prevents infestation by tomato potato psyllid; and
 - (v) undergo a 2% or 600 unit inspection and found free of tomato potato psyllid; or
- (5) in the case of flowers and ornamental foliage of Category 1 (excluding ornamental fruits), be –
 - (a) fumigated with 1000 g/kg active constituent methyl bromide at:
 - (i) 10°C – 10.9°C @ 56 g/m³ for 2 hours; or
 - (ii) 11°C – 15.9°C @ 48 g/m³ for 2 hours; or
 - (iii) 16°C – 20.9°C @ 40 g/m³ for 2 hours; or
 - (iv) 21°C – 31.9°C @ 32 g/m³ for 2 hours; and
 - (b) immediately after treatment, the flowers and ornamental foliage are placed in secure conditions that prevent infestation of tomato potato psyllid; or
- (6) in the case of cut flowers and ornamental foliage of Category 2, be –
 - (a) treated with one of the following pesticide treatments in accordance with the chemical label or APVMA permit, ensuring the treatment makes contact with the underside of the flower and/or foliage –
 - (i) abamectin within 3 days prior to dispatch;
 - (A) with 18 g/L active constituent at a rate of 90 mL/100 L or 450 mL/ha, plus 500 mL of Summer Spray Oil; or
 - (B) with 36 g/L active constituent at a rate of 45 mL/100 L or 225 mL/ha, plus 500 mL of Summer Spray Oil; or

- (ii) bifenthrin within 3 days prior to dispatch;
 - (A) with 100 g/L active constituent at a rate of 80 mL/100 L; or
 - (B) with 250 g/L active constituent at a rate of 32 mL/100 L; or
- (iii) methomyl within 3 days prior to dispatch, with active ingredient of 225 g/L at rate of 200 mL/100 L; or
- (iv) post-harvest treated with deltamethrin with 25 g/L active constituent at a rate of 100 mL/100 L for not less than 3 minutes and left to dry naturally for 2 hours, ensuring that the cut flowers and/or foliage are fully submerged; and
- (v) immediately after treatment, the flowers and ornamental foliage is placed in secure conditions that prevent infestation of tomato potato psyllid; and
- (vi) undergo a 2% or 600 unit inspection and found free of tomato potato psyllid; or
- (b) fumigated –
 - (i) with 1000 g/kg active constituent methyl bromide at:
 - (A) 10°C – 10.9°C @ 56 g/m³ for 2 hours; or
 - (B) 11°C – 15.9°C @ 48 g/m³ for 2 hours; or
 - (C) 16°C – 20.9°C @ 40 g/m³ for 2 hours; or
 - (D) 21°C – 31.9°C @ 32 g/m³ for 2 hours; or
 - (ii) with 166.7 g/kg active constituent ethyl formate at greater than 15°C @ 25 g/m³ for 1 hour; and
 - (iii) immediately after treatment, the material is placed in secure conditions that prevent infestation of tomato potato psyllid; or
- (7) in the case of strawberries, be –
 - (a) securely packed in a packhouse following sorting and grading; and
 - (b) undergo a 600 unit post-harvest inspection and found free of tomato potato psyllid; and
 - (c) packed in approved manner to prevent infestation with tomato potato psyllid; or
- (8) in the case of used agricultural equipment and used packages be –
 - (a) cleaned free of soil and organic matter by –
 - (i) brushing; or
 - (ii) high pressure hot water heated to a temperature of at least 70°C; or
 - (iii) steam.

Dated 29 September 2021

ROSA CRNOV
Chief Plant Health Officer

Water Act 1989**CENTRAL GIPPSLAND REGION WATER CORPORATION –
DECLARATION OF SERVICED PROPERTIES**

Pursuant to section 144 of the **Water Act 1989**, Central Gippsland Region Water Corporation declares the following land to be serviced property for the services listed below on or from the Declaration Date/s listed below.

Address	Service	Subdivision No.	Declaration Date
Kavanagh Street, Manley Circuit and Waterside Drive, Traralgon	Water and Sewerage	PS838403 E	02/09/2021
Coach Road and Gleneagles Drive, Newborough	Water and Sewerage	PS829358 H	14/09/2021
Bolden and Lloyd Street, Stratford	Water and Sewerage	PS846470 S	17/09/2021
Silver Wattle Drive and Magnolia Way, Drouin	Water and Sewerage	PS834223 D	17/09/2021
Raglan Street, Sale	Water and Sewerage	PS836909 F	22/09/2021

Water Act 1989**NOTICE OF PROPOSED MODEL WATER RESTRICTION BY-LAW**

I, Lisa Neville MP, Minister for Water, give notice under section 287Y of the **Water Act 1989** of my proposal to issue a model by-law in relation to regulating, restricting or prohibiting the use of water supplied by Victorian urban water authorities. The model by-law has been developed in partnership with the water industry and will allow Victorian urban water authorities to replace their current by-laws that will expire from December 2021.

The purpose of the model by-law is to:

- conserve water during a water shortage or water supply emergency;
- set out the four stages of urban water restrictions;
- specify what must not be done when a stage of restriction is in place;
- specify principles for considering exemptions;
- prescribe offences and penalties for the contravention of the by-law;
- prescribe classes of persons for the purpose of serving infringement notices.

You can obtain a copy of the proposed model by-law, free of charge, by:

- viewing or downloading from engage.vic.gov.au/renewingwaterrestrictionbylaws;
- emailing water.efficiency@delwp.vic.gov.au;
- calling 136 186.

You are invited to make a submission on the model by-law.

Submissions can be made by filling out the survey or uploading a submission on the *We're renewing Victoria's Water Restriction By-law* page at engage.vic.gov.au/renewingwaterrestrictionbylaws

The closing date for submissions is 5 pm Tuesday 9 November 2021.

For further assistance about the public comment process, or to obtain copies of the model by-law, please call 136 186.

LISA NEVILLE MP
Minister for Water
www.delwp.vic.gov.au
Customer Service Centre 136 186

This page was left blank intentionally

This page was left blank intentionally

This page was left blank intentionally

**SUBORDINATE LEGISLATION ACT 1994
NOTICE THAT STATUTORY RULES ARE
OBTAINABLE**

Notice is hereby given under section 17(3) of the **Subordinate Legislation Act 1994** that the following Statutory Rule was first obtainable from TIMG Bookshop, Level 10, 575 Bourke Street, Melbourne 3000, on the date specified:

126. *Statutory Rule:* Tobacco (Victorian Health Promotion Foundation) Further Amendment Regulations 2021

Authorising Act: Tobacco Act 1987

Date first obtainable: 5 October 2021

Code A

PRICING FOR SPECIAL GAZETTE, PERIODICAL GAZETTE AND VICTORIAN LEGISLATION

Retail price varies according to the number of pages in each Victoria Government Special Gazette, Victoria Government Periodical Gazette and Victorian legislation. The table below sets out the prices that apply.

<i>Price Code</i>	<i>No. of Pages (Including cover and blank pages)</i>	<i>Price*</i>
A	1–16	\$4.22
B	17–32	\$6.33
C	33–48	\$8.65
D	49–96	\$13.61
E	97–144	\$17.51
F	145–192	\$20.78
G	193–240	\$23.95
H	241–288	\$25.43
I	289–352	\$28.70
J	353–416	\$33.44
K	417–480	\$38.19
L	481–544	\$44.52
M	545–608	\$50.90
N	609–672	\$56.28
O	673–736	\$63.62
P	737–800	\$70.10
#Q	821–886	\$76.22
#R	887–950	\$81.29
#S	951–1016	\$86.83
#T	1017–1080	\$92.21
#U	1081–1146	\$97.75
#V	1147–1210	\$103.50
#W	1211–1276	\$108.88
#X	1277–1340	\$114.78
#Y	1341–1406	\$119.95

<i>Price Code</i>	<i>No. of Pages (Including cover and blank pages)</i>	<i>Price*</i>
#Z	1407–1470	\$125.60
#ZA	1471–1536	\$131.56
#ZB	1537–1610	\$136.57
#ZC	1611–1666	\$142.32
#ZD	1667–1730	\$147.70
#ZE	1731–1796	\$153.66
#ZF	1797–1860	\$159.20
#ZG	1861–1926	\$164.42
#ZH	1927–1990	\$170.38
#ZI	1991–2056	\$175.76

* All prices include GST

Printed as two volumes

ive

The *Victoria Government Gazette* is published by IVE Group Limited with the authority of the Government Printer for the State of Victoria

© State of Victoria 2021

This publication is copyright. No part may be reproduced by any process except in accordance with the provisions of the Copyright Act.

Address all enquiries to the Government Printer for the State of Victoria
Level 2, 1 Macarthur Street
Melbourne 3002
Victoria Australia

How To Order



**Retail &
Mail Sales**

Victoria Government Gazette
Ground Floor, Building 8,
658 Church Street,
Richmond 3121

DX 106 Melbourne



Telephone

(03) 8523 4601

email

gazette@ivegroup.com.au

Recommended Retail Price \$2.55 (includes GST)