



# Victoria Government Gazette

By Authority of Victorian Government Printer

**No. G 7 Thursday 13 February 2025**

[www.gazette.vic.gov.au](http://www.gazette.vic.gov.au)

**GENERAL**

## TABLE OF PROVISIONS

|                                   |     |                                       |     |
|-----------------------------------|-----|---------------------------------------|-----|
| Private Advertisements            |     | Government and Outer Budget Sector    |     |
| Estates of Deceased Persons       |     | Agencies Notices                      | 186 |
| Alphastream Lawyers               | 180 | Orders in Council                     | 202 |
| Bracken Lawyers                   | 180 | Crown Land (Reserves);                |     |
| David Davis & Associates          | 180 | Land;                                 |     |
| Davis Lawyers                     | 180 | Major Transport Projects Facilitation |     |
| Featherbys Lawyers                | 180 | Obtainables                           | 206 |
| Hartwell Legal                    | 180 |                                       |     |
| Hutchinson Legal                  | 181 |                                       |     |
| I. Glenister & Associates         | 181 |                                       |     |
| John Keating and Associates       | 181 |                                       |     |
| Karolidis and Co.                 | 181 |                                       |     |
| Leonard and Associates            | 181 |                                       |     |
| MCL Legal                         | 181 |                                       |     |
| Mahons with Yuncken & Yuncken     | 182 |                                       |     |
| Middlemis & Associates            | 182 |                                       |     |
| Monica Baumgartner                | 182 |                                       |     |
| Moores                            | 182 |                                       |     |
| Morgan Couzens Legal              | 182 |                                       |     |
| NWF Lawyers                       | 182 |                                       |     |
| Nathan Yii Lawyers                | 183 |                                       |     |
| Parke Lawyers Pty Ltd             | 183 |                                       |     |
| Pearce Webster Dugdales           | 183 |                                       |     |
| Peter Cahill                      | 183 |                                       |     |
| Rennick & Gaynor                  | 184 |                                       |     |
| Suzanne Lyttleton Lawyers Pty Ltd | 184 |                                       |     |
| Whyte, Just & Moore               | 184 |                                       |     |
| Sales by the Sheriff              |     |                                       |     |
| Adam Mustafa                      | 185 |                                       |     |

---

### Advertisers Please Note

As from 13 February 2025

The last Special Gazette was No. 46 dated 12 February 2025.

The last Periodical Gazette was No. 1 dated 29 May 2024.

---

### How To Submit Copy

- See our webpage [www.gazette.vic.gov.au](http://www.gazette.vic.gov.au)
  - or contact our office on 03 8523 4601  
between 8.30 am and 5.30 pm Monday to Friday
-

**PUBLICATION OF THE VICTORIA GOVERNMENT GAZETTE (GENERAL)  
LABOUR DAY HOLIDAY WEEK 2025 (Monday 10 March 2025)**

**Please Note:**

The Victoria Government Gazette (General) for LABOUR DAY holiday week (G11/25) will be published on **Thursday 13 March 2025**.

**Copy Deadlines:**

Private Advertisements **9.30 am on Friday 7 March 2025**

Government and Outer

Budget Sector Agencies Notices **9.30 am on Tuesday 11 March 2025**

**Office Hours:**

The Victoria Government Gazette Office is open during normal office hours over the holiday period, i.e. 8.30 am to 5.30 pm Monday to Friday, excluding public holidays.

Where urgent gazettal is required after hours, arrangements should be made with the Government Gazette Officer on 0419 327 321.

KIM BURNESSE  
Government Gazette Officer

---

## PRIVATE ADVERTISEMENTS

NOEL FRANCES WRIGHT, late of 26 Glenn Street, Shepparton, Victoria, retired, deceased.

Creditors, next-of-kin and others having claims in respect of the estate of the deceased, who died on 18 September 2024, are required by Lois Susanne Comeadow, the executor of the Will of the deceased, to send particulars thereof to her, care of the undermentioned solicitors, by 14 April 2025, after which date the executor may convey or distribute the assets, having regard only to the claims of which she then has notice.

Dated 13 February 2025

ALPHASTREAM LAWYERS,  
Suite 12, 622 Ferntree Gully Road,  
Wheelers Hill, Victoria 3150.

Re: MINH CONG LE, late of Unit 4, 391 York Street, Sale, Victoria, unemployed, deceased.

Creditors, next-of-kin and all others having claims in respect of the estate of the abovementioned deceased, who died on 15 July 2023, are required by the executor, Chloe Monique Le-Dodd, to send particulars of such claims to her, care of the undermentioned solicitors, by 15 April 2025, after which date the executor may convey or distribute the assets, having regard only to the claims of which she then has notice.

DAVIS LAWYERS,  
Level 15, 200 Queen Street, Melbourne,  
Victoria 3000.  
Tel: 03 9600 1800.

Re: REGINALD JAMES MACDONALD, late of 50 Martin Street, McKenzie Hill, Victoria 3451, retired, deceased.

Creditors, next-of-kin and others having claims in respect of the estate of the abovenamed deceased, who died on 7 May 2024, are required by the executor, Leeanne MacDonald, to send particulars of such claims to her, care of the undermentioned solicitors, by 11 April 2025, after which date the executor will convey or distribute the assets, having regard only to the claims of which she then has notice.

BRACKEN LAWYERS,  
3/233 Barker Street, Castlemaine, Victoria 3450.

Re: CONSTANCE MASTERS, deceased.

Creditors, next-of-kin and others having claims in respect of the estate of the deceased, who died on 15 December 2024, are required by the trustee, Colin Phillip Kelly, care of Featherbys Lawyers of 14 Ninth Avenue, Rosebud, Victoria, to send particulars to the trustee by 13 April 2025, after which date the trustee may convey or distribute the assets, having regard only to the claims of which the trustee has notice.

FEATHERBYS LAWYERS, solicitors,  
14 Ninth Avenue, Rosebud, Victoria 3939.

EDWARD GRAEME MARSHALL, late of 4 Conder Avenue, Burwood, Victoria 3125, deceased.

Creditors, next-of-kin and others having claims in respect of the estate of the deceased, who died on 28 December 2024, are required by the executors, Elizabeth Anne Marshall and Peter Graeme Marshall, to send particulars to them, care of the undermentioned solicitors, by 15 April 2025, after which date they may convey or distribute the assets, having regard only to the claims of which they then have notice.

DAVID DAVIS & ASSOCIATES,  
Suite 2, 733 High Street, Thornbury,  
Victoria 3071.

### Trustee Act 1958

(SECTION 33 NOTICE)

Notice to Claimants

CORNELIA JOHANNA WILHELMINA ZEGVELD, late of 400 Waverley Road, Malvern East, Victoria 3145, retired sales assistant, deceased.

Creditors, next-of-kin and others having claims in respect of the estate of the deceased, who died on 12 April 2024, are required by Maureen Wilhelmina Duncan, care of Hartwell Legal of 8/1 Milton Parade, Malvern, Victoria 3144, the executor of the estate of the deceased, to send particulars of their claims by 14 April 2025, after which date the executor may

convey or distribute the assets, having regard only to the claims of which she then has notice.

HARTWELL LEGAL,  
8/1 Milton Parade, Malvern, Victoria 3144.

---

BERYL MARJORY BAKER, late of Waverley Valley Care Community, 29–33 Chesterville Road, Glen Waverley, Victoria 3150, secretary, deceased.

Creditors, next-of-kin and others having claims in respect of the estate of the deceased, who died on 10 April 2024, are required by the personal representative, Donald Frederick Strickland, to send particulars of such claim to him, care of the undersigned, by 13 April 2025, after which date the personal representative may convey or distribute the assets, having regard only to the claims of which he then has notice.

HUTCHINSON LEGAL,  
38 New Street, Ringwood, Victoria 3134.

---

SHIRLEY GERTRUDE GRACE WATTS, late of 25 Woods Road, Yan Yean, Victoria, deceased.

Creditors, next-of-kin and others having claims in respect of the estate of the deceased, who died on 10 September 2023, are required by the executor, Rodney Mark Billington, to send particulars of their claims to the executor, care of the undermentioned solicitor, within 60 days from the publication hereof, after which date the executor may convey or distribute the assets, having regard only to the claims of which the executor and his undermentioned solicitors then have notice.

I. GLENISTER & ASSOCIATES, solicitors,  
421 Bell Street, Pascoe Vale, Victoria 3044.

---

Re: JAMES HUBERT CHADBURN GRETTON, late of Unit 1, 7 Ellesmere Road, Prahran, Victoria 3181, carpet layer, deceased.

Creditors, next-of-kin and others having claims in respect of the estate of the deceased, who died on 5 November 2024, are required by the executor and trustee, Sandra Mary Kitching, to send particulars to them, care of the undermentioned lawyers, by 7 April 2025, after which date the executor and trustee may

convey or distribute the assets, having regard only to the claims of which they have notice.

JOHN KEATING AND ASSOCIATES,  
191 Greville Street, Prahran, Victoria 3181.

---

CHRISTINE EUGENIE ROSCH, also known as Christine Rosch, late of 30 Strathconnon Square, Tullamarine, Victoria 3043, bookkeeper, deceased.

Creditors, next-of-kin and others having claims in respect of the estate of the abovementioned deceased, who died on 2 November 2024, are required by the executor, Jo'anne Gowing, in the Will called Joanne Allen, to send particulars of their claims to her, care of the undermentioned lawyers, by a date not later than two months from the date of publication hereof, after which date the executor may convey or distribute the assets and distribute the estate, having regard only to the claims of which she then has notice.

KAROLIDIS AND CO.,  
Shop 2 and 3, 785 Pascoe Vale Road, Glenroy, Victoria 3046.  
Ph: 03 9942 7790.  
DM:24/2616.  
Contact: Nick Karolidis.

---

Re: KENNETH JAMES ANTHONY, late of 14 Dixon Street, Surf Beach, Victoria 3922, deceased.

Creditors, next-of-kin and others having claims in respect of the estate of the deceased, who died on 12 March 2024, are required to send particulars of their claim to the executor, care of the undersigned lawyers, by 14 April 2025, after which date the executor may convey or distribute the assets, having regard only to the claims of which they then have notice.

LEONARD AND ASSOCIATES, lawyers,  
Level 1, 82 Thompson Avenue, Cowes, Victoria 3922.

---

LILLIAN BETTY LEE, late of Kara Court Nursing Home, 52 North Western Road, Saint Arnaud, Victoria 3478, sales assistant, deceased.

Creditors, next-of-kin and others having claims in respect of the Will of the abovenamed

deceased, who died on 26 July 2024, are required by the executors, Heather Jean Leonard and Frederick John Leonard, care of the undermentioned solicitor, to send particulars of their claims to them by 22 April 2025, after which date the executors may convey or distribute the assets, having regard only to the claims of which they then have notice.

MCL LEGAL,  
78 Napier Street, St Arnaud, Victoria 3478.

Re: Estate of BARRY ROBERT REBECCA, late of Unit 20, 110 Hull Road, Croydon, Victoria, deceased.

Creditors, next-of-kin and others having claims in respect of the estate of the deceased, who died on 15 February 2024, are required by the trustee, Scott Anthony Rebecca, to send particulars to the trustee, care of the undermentioned solicitors, by 14 April 2025, after which date the trustee may convey or distribute the assets, having regard only to the claims of which the trustee then has notice.

MAHONS with Yuncken & Yuncken, solicitors,  
177 Surrey Road, Blackburn, Victoria 3130.  
Ref No: PH:2242021.

AMANDA DOONE ROBERTSON, late of 189 Booth Road, Woodvale, Victoria, home duties, deceased.

Creditors, next-of-kin and others having claims in respect of the estate of the abovenamed deceased, who died on 28 September 2024, are required by James Alan Middlemis and Cathrine Harboe-Ree, the executors of the Will of the deceased, to send particulars of their claims to them, care of the undermentioned address, by 21 April 2025, after which date the executors may convey or distribute the assets, having regard only to the claims of which they then have notice.

MIDDLEMIS & ASSOCIATES, lawyers,  
30 Myers Street, Bendigo, Victoria 3550.

Re: ANDREW BARRY WADE BAUMGARTNER, late of 515 Lynnes Road, Wattle Bank, Victoria.

Creditors, next-of-kin and others having claims in respect of the estate of the deceased, who died on 24 August 2024, are required by the

executor, Monica Baumgartner, to send particulars of any claim to the estate of ANDREW BAUMGARTNER, PO Box 99, Noonamah, Northern Territory 0837, by 14 April 2025, after which date the executor may convey or distribute the assets, having regard only to the claims of which the executor then has notice.

Re: MARJORIE BERYL DAY, deceased, late of 48 Dorking Road, Box Hill, Victoria.

Creditors, next-of-kin and others having claims in respect of the estate of the deceased, who died on 18 September 2024, are required by the executors, Richard Wharton Day and Bruce Graham Day, to send particulars to the executors, care of the undermentioned solicitors, by 20 April 2025, after which date the executors may convey or distribute the assets, having regard only to the claims of which the executors then have notice.

MOORES,  
Level 1, 5 Burwood Road, Hawthorn,  
Victoria 3122.

DAVID JOHN RYAN, late of 16 Cribbes Road, Wangaratta, Victoria 3677, deceased.

Creditors, next-of-kin and others having claims in respect of the estate of the deceased, who died on 9 April 2024, are required by the executor, James Alfred Ryan, to send particulars to him, care of the undermentioned solicitors, by 24 April 2025, after which date the executor may convey or distribute the assets, having regard only to the claims of which he then has notice.

MORGAN COUZENS LEGAL,  
Ground Floor, Suite 10, 21–23 Reid Street,  
Wangaratta 3677.  
Email: reception@morgancouzenslegal.com.au  
Ref: WC:9589.

PETER RICHARD BLAYNEY, late of Bupa Aged Care, 305 Smythes Road, Delacombe, Victoria 3356, deceased.

Creditors, next-of-kin and others having claims in respect of the Will/estate of the abovenamed deceased, who died on 26 October 2024, are required by the executor,

Benjamin Ronald Franklin, care of 41 Lydiard Street South, Ballarat, Victoria 3350, to send particulars of their claims to him by 13 April 2025, after which date the executor may convey or distribute the assets, having regard only to the claims of which he then has notice. Probate was granted in Victoria on 27 December 2024.

NWF LAWYERS,  
41 Lydiard Street South, Ballarat, Victoria 3350.  
Ph: 03 5331 1244.  
Ref: 241310.

---

MARY JANE EDWARDS, late of Mercy Place, 60 Corbett Street, Ballarat East, Victoria 3350, deceased.

Creditors, next-of-kin and others having claims in respect of the Will/estate of the abovenamed deceased, who died on 5 August 2024, are required by the executor, Benjamin Ronald Franklin, care of 41 Lydiard Street South, Ballarat, Victoria 3350, to send particulars of their claims to him by 13 April 2025, after which date the executor may convey or distribute the assets, having regard only to the claims of which he then has notice. Probate was granted in Victoria on 20 December 2024.

NWF LAWYERS,  
41 Lydiard Street South, Ballarat, Victoria 3350.  
Ph: 03 5331 1244.  
Ref: 240991.

---

DAVID GEORGE HOWORTH, late of Keilor, Victoria.

Creditors, next-of-kin and others having claims in respect of the estate of the deceased, who died on 29 May 2024, are required to send particulars of their claims to the executor, care of Nathan Yii Lawyers Pty Ltd, Level 1, 34 Queen Street, Melbourne, Victoria 3000, by 27 April 2025, after which date the executor may convey or distribute the assets, having regard only to the claims of which they may then have notice.

---

ANDREW WILLIAM KERR, late of Fitzroy, Victoria.

Creditors, next-of-kin and others having claims in respect of the estate of the deceased,

who died on 29 July 2024, are required to send particulars of their claims to the executors, care of Nathan Yii Lawyers Pty Ltd, Level 1, 34 Queen Street, Melbourne, Victoria 3000, by 27 April 2025, after which date the executors may convey or distribute the assets, having regard only to the claims of which they may then have notice.

---

Re: Estate of KIERAN FRANCIS GLYNN, deceased, late of 18 Le John Street, Rowville, Victoria 3178.

Creditors, next-of-kin and others having claims in respect of the estate of the deceased, who died on 29 June 2024, are required by the executor of the estate, John Mortimer Glynn, to send particulars of their claims to the trustees, care of the undermentioned solicitors, by a date not later than two months from the date of publication of this advertisement, after which date the executor may convey or distribute the assets, having regard only to the claims of which they then have notice.

PARKE LAWYERS PTY LTD,  
281 Maroondah Highway, Ringwood,  
Victoria 3134.

---

Re: AUDREY NINETTE FERDINANDS, deceased.

Creditors, next-of-kin and others having claims in respect of the estate of the deceased, who died on 21 September 2024, are required by the trustees, Johann Frederic Anthony Ferdinands and Hans Nicholas Ferdinands, to send particulars to them, care of the undermentioned solicitors, by 24 April 2025, after which date they may convey or distribute the assets, having regard only to the claims of which they then have notice.

PEARCE WEBSTER DUGDALES, lawyers,  
Suite 1, Ground Floor, 99 Queens Bridge Street,  
Southbank, Victoria 3006.

---

Re: VERONICA ELIZABETH ZIOLA, 240 Holdsworth Road, North Bendigo, Victoria 3550.

Creditors, next-of-kin and others having claims in respect of the estate of the deceased, who died on 6 March 2024, are required by



the executors, Sharon Melissa Kitt and Adam Troy Barbary, to send particulars of their claim to them, care of the undermentioned solicitor, by 60 days from today's date, after which date the executors may convey or distribute the assets, having regard only to the claims of which they then have notice.

PETER CAHILL, solicitor,  
48 Edward Street, Bendigo, Victoria 3550.

---

Re: VALERIE LASZLO, late of 12 Bowman Street, Corinella, Victoria 3984, social worker, deceased.

Creditors, next-of-kin and others having claims in respect of the estate of the abovenamed deceased, who died on 23 September 2024, are required by the executor, Kenneth Anthony Bartel, to send particulars of their claims to him, care of the undermentioned solicitors, by 15 April 2025, after which date he may convey or distribute the assets, having regard only to the claims of which he then has notice.

RENNICK & GAYNOR, solicitors,  
431 Riversdale Road, Hawthorn East,  
Victoria 3123.  
Email: willsandestates@rennicks.com.au  
Ref: EMC:245158.

---

Re: ADELE CSELEDY late of 24 Vule Street, St Albans, Victoria, factory worker, deceased.

Creditors, next-of-kin and others having claims in respect of the estate of the deceased, who died on 1 December 2022, are required by the administrator, Hayley Elizabeth Hunter, to send particulars to her, care of the undermentioned lawyers, by a date not later than two months from the date of publication hereof, after which date the administrator will convey or distribute the assets, having regard only to the claims of which she then has notice.

SUZANNE LYTTLETON LAWYERS  
PTY LTD,  
PO Box 2181, St Kilda West, Victoria 3182.  
Telephone: 03 9646 4477.

---

ZOE ALLISON HARRIS, late of Hope Aged Care, 14 South Circular Road, Gladstone Park, Victoria 3043, retail assistant, deceased.

Creditors, next-of-kin and others having claims in respect of the estate of the deceased, who died on 28 November 2024, are required by the legal personal representative, Australian Unity Trustees Limited, ACN 162 061 556, to send particulars of their claims to the legal personal representative, care of the undermentioned solicitors, by 21 April 2025, after which date the legal personal representative may convey or distribute the assets, having regard only to the claims of which the legal personal representative then has notice.

WHYTE, JUST & MOORE, solicitors,  
Level 2, 100 Brougham Street, Geelong,  
Victoria 3220.

---

KATHLEEN JUNE MORAN, late of 4 Craddock Street, North Geelong, Victoria 3215, retired, deceased.

Creditors, next-of-kin and others having claims in respect of the estate of the abovenamed deceased, who died on 17 December 2024, are required by the executors, Aaron Martin Jolly and Benjamin William Punivalu, to send particulars of their claims to them, care of the undermentioned solicitors, by 21 April 2025, after which date the executors may convey or distribute the assets, having regard only to the claims of which they then have notice.

WHYTE, JUST & MOORE, solicitors,  
Level 2, 100 Brougham Street, Geelong,  
Victoria 3220.

---

KAYE SALISBURY, late of 200 Buckley Road North, Buckley, Victoria 3240, clerk, deceased.

Creditors, next-of-kin and others having claims in respect of the estate of the abovenamed deceased, who died on 21 June 2024, are required by the substitute executor, Abby Jane Robinson, to send particulars of their claims to her, care of the undermentioned solicitors, by 21 April 2025, after which date the substitute executor may convey or distribute the assets, having regard only to the claims of which she then has notice.

WHYTE, JUST & MOORE, solicitors,  
Level 2, 100 Brougham Street, Geelong,  
Victoria 3220.

---



BART WISSINK, late of 200 Buckley Road North, Buckley, Victoria 3240, retired, deceased.

Creditors, next-of-kin and others having claims in respect of the estate of the abovenamed deceased, who died on 21 June 2024, are required by the substitute executor, Abby Jane Robinson, to send particulars of their claims to her, care of the undermentioned solicitors, by 21 April 2025, after which date the substitute executor may convey or distribute the assets, having regard only to the claims of which she then has notice.

WHYTE, JUST & MOORE, solicitors,  
Level 2, 100 Brougham Street, Geelong,  
Victoria 3220.

sheet on Sheriff's Auctions, a contract of sale and further information. Alternately, you can contact the Sheriff's Office Victoria Real Estate Section at [realestatesection@justice.vic.gov.au](mailto:realestatesection@justice.vic.gov.au)

SHERIFF OF VICTORIA

---

ADVERTISEMENT OF ONLINE AUCTION  
BY THE SHERIFF

On Tuesday 18 March 2025 at 11.00 am, unless process is stayed or satisfied, all the estate and interest, if any, of the person(s) named below, in the land described below, will be auctioned online by the Sheriff.

Adam Richard John Mustafa of Unit 46, 11–13 Cooma Street, Preston, Victoria 3072, sole proprietor of an estate in fee simple in the land described on Certificate of Title Volume 10185 Folio 570 upon which is erected a unit and known as Unit 46, 11–13 Cooma Street, Preston, Victoria 3072.

The following recordings in the Register affect or may affect the land as at 11 February 2025:

- Owners Corporation Plan No. PS336129W.

The Sheriff is unable to provide access to these properties.

Terms: 10% deposit on the fall of the hammer. Balance within 14 days unless as stated in particulars of sale in contract of sale. Payment is by EFT only, using OSKO.

Note: This is an online auction only. Online registration is required. A copy of the registration form can be obtained from the website listed below. All registration forms must be emailed to [realestatesection@justice.vic.gov.au](mailto:realestatesection@justice.vic.gov.au) prior to the auction, to participate.

Please visit the Sheriff's Office Victoria Real Estate Section website at [www.justice.vic.gov.au/sheriffrealestate](http://www.justice.vic.gov.au/sheriffrealestate) for an information

**GOVERNMENT AND OUTER BUDGET  
SECTOR AGENCIES NOTICES**



**Colac Otway**  
SHIRE

**ROAD DISCONTINUANCE**

At its meeting on 24 July 2024 and acting under section 206 and Clause 3 of Schedule 10 to the **Local Government Act 1989**, Colac Otway Shire Council resolved to discontinue the government road located at Hart Street, parallel to 80a Hart Street, Colac, being the land shown hatched in the plan below.

Once discontinued, the former road will vest in the Colac Otway Shire Council and it will be consolidated into the title for 80a Hart Street, Colac.

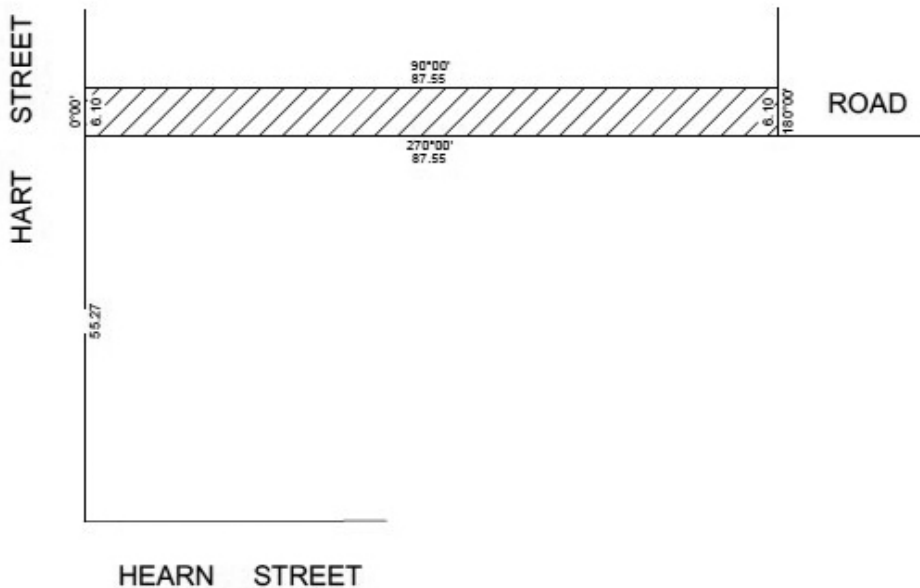

THE ROAD PROPOSED TO BE DISCONTINUED IS SHOWN HATCHED AND IS ENCLOSED BY THICK CONTINUOUS LINES

ANNE HOWARD  
Chief Executive Officer  
Colac Otway Shire Council



GLEN EIRA  
CITY COUNCIL

ROAD DISCONTINUANCE

At its meeting on 3 December 2024 and acting under Clause 3 of Schedule 10 to the **Local Government Act 1989**, Glen Eira City Council resolved to discontinue and sell the road abutting 333–345 Hawthorn Road and 2 Briggs Street, Caulfield, which is part of the land contained in Certificate of Title Volume 2343 Folio 478 and shown hatched on the plan below (Road).

PARISH OF PRAHRAN AT CAULFIELD  
CROWN PORTION 44 (PART)

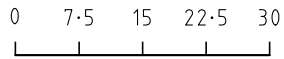

LENGTHS ARE IN METRES

BRIGGS STREET

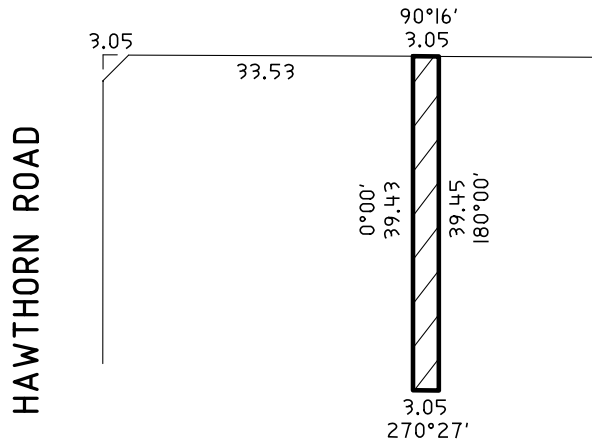

HAWTHORN ROAD

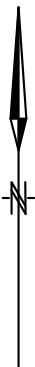

REBECCA McKENZIE  
Chief Executive Officer  
Glen Eira City Council

**Planning and Environment Act 1987****GLEN EIRA PLANNING SCHEME**Notice of the Preparation of an  
Amendment to a Planning Scheme

## Amendment C256glen

The Glen Eira City Council planning authority has prepared Amendment C256glen to the Glen Eira Planning Scheme.

The land affected by the Amendment is within the Elsternwick Major Activity Centre (MAC). This includes the main retail, cultural, urban renewal, and housing opportunity precincts of the centre.

The Amendment proposes to implement the built form and land use recommendations of the *Elsternwick Structure Plan (2023)* into the Glen Eira Planning Scheme.

Specifically, the Amendment proposes to:

- replace the existing interim Design and Development Overlay Schedule 10 (DDO10) to Clause 43.02 with a new DDO10 that introduces permanent planning controls;
- rezone land to allow for mixed land uses and greater housing diversity as follows:
  - from Neighbourhood Residential Zone 1 (NRZ1) to Residential Growth Zone 1 (RGZ1): 1, 3 and 5 Bent Street; 35, 37, 2/37, 3/37, 39, 41, 43, 45 and 47 Gordon Street; 5, 7, 14, 16, 18, 20 and 22 McMillan Street; 37, 39 and 41 Nepean Highway;
  - from General Residential Zone 2 (GRZ2) to RGZ1: 21/39 Horne Street; 9 McMillan Street; 35 Nepean Highway; 1 Downshire Road;
  - from RGZ1 to Mixed Use Zone 1 (MUZ1): 2 and 8 Gordon Street;
  - from RGZ1 to Commercial 1 Zone (C1Z): 201 and 205 Glenhuntly Road; 2 Miller Street;
- rezone land currently in two zones into a single zone in alignment with properties boundaries as follows:
  - from C1Z and RGZ1 to C1Z: 207 Glenhuntly Road; 230–234 Glenhuntly Road; 5 Horne Street;
  - from MUZ1 and NRZ1 to MUZ1: 511–513, 515, 517, 519, 521 and 523 Glenhuntly Road;

- Update the DDO10 map by applying it to the same properties but also adding the following properties:
  - 2 Miller Street;
  - 2 and 8 Gordon Street;
  - 201, 205, 525, 527, 529, 531, 533, 535 and 537 Glenhuntly Road;
  - remainder of 207, 230–234, 296–298, 511–513, 515, 517, 519, 521 and 523 Glenhuntly Road;
  - remainder of 5 Horne Street;
- update the local policy for the Elsternwick MAC by amending the Planning Policy Framework at Clauses 02.03-1 (settlement and activity centres), 02.04-1 (Strategic Framework Plan), 11.03-1L (activity centres), 15.01-2L-01 (building design), 16.01-1L-01 (housing supply), and 18.02-4L-02 (car parking);
- amend the Schedule to Clause 72.08 by removing DDO10 as a Clause reference from the *Quality Design Guidelines* and by introducing the *Elsternwick Structure Plan* as a background document.

You may inspect the Amendment, any documents that support the Amendment and the explanatory report about the Amendment, free of charge, at: the Glen Eira City Council website at [www.haveyoursaygleneira.com.au/amendmentc256](http://www.haveyoursaygleneira.com.au/amendmentc256); during office hours, at the office of the planning authority, Glen Eira City Council, corner Glen Eira and Hawthorn Roads, Caulfield; and/or at the Department of Transport and Planning website, [www.planning.vic.gov.au/public-inspection](http://www.planning.vic.gov.au/public-inspection) or by contacting 1800 789 386 to arrange a time to view the Amendment documentation.

Any person may make a submission to the planning authority about the Amendment. Submissions must be made in writing giving the submitter's name and contact address, clearly stating the grounds on which the Amendment is supported or opposed and indicating what changes, if any, the submitter wishes to make.

Name and contact details of submitters are required for the planning authority to consider submissions and to notify such persons of the opportunity to attend planning authority meetings and any public hearing held to consider submissions.

The closing date for submissions is 28 March 2025. A submission must be sent to Glen Eira City Council via one of the following methods: online: [www.haveyoursaygleneira.com.au/amendmentc256](http://www.haveyoursaygleneira.com.au/amendmentc256); by email: [cityfutures@gleneira.vic.gov.au](mailto:cityfutures@gleneira.vic.gov.au); by mail: City Futures, Glen Eira City Council, PO Box 42, Caulfield South, Victoria 3162; or in person: corner Glen Eira and Hawthorn Roads, Caulfield.

The planning authority must make a copy of every submission available at its office and/or on its website for any person to inspect, free of charge, until the end of the two months after the Amendment comes into operation or lapses.

MATT SLAVIN  
Manager City Futures

### **Planning and Environment Act 1987**

#### **WARRNAMBOOL PLANNING SCHEME**

##### Notice of the Preparation of an Amendment to a Planning Scheme Amendment C219warr

#### **Overview**

The Amendment updates the North of the Merri River Structure Plan (Mesh Pty Ltd, September 2011) and North of the Merri River Development Contributions Plan (Mesh, September 2011) to delete reference to the undergrounding of the existing high voltage powerlines; extends the life of the Development Contributions Plan from ten (10) years to (25) years; and updates the Structure Plan and Development Contributions Plan version reference to May 2024.

For further details, refer to the explanatory report about the Amendment.

#### **Details of the Amendment**

The Warrnambool City Council planning authority has prepared Amendment C219warr to the Warrnambool Planning Scheme.

The land affected by the Amendment is confined within the North of the Merri River Structure Plan area, generally bound by Wollaston Road and a ridge line to the north, Caramut Road to the west and the Merri River to the south and east.

The Amendment proposes to update the North of the Merri River Structure Plan and Development Contributions Plan to delete reference to the undergrounding of the existing

high voltage powerlines. The change will provide benefit to the community by way of reduced costs to Council which will help support growth and the delivery of housing. The timeframe of the Development Contributions Plan has been extended as part of the updates.

The Amendment updates the version references of the North of the Merri River Structure Plan and Development Contributions Plan within the Warrnambool Planning Scheme.

You may inspect the Amendment, any documents that support the Amendment and the explanatory report about the Amendment, free of charge, at: the Department of Transport and Planning website, [www.planning.vic.gov.au/public-inspection](http://www.planning.vic.gov.au/public-inspection) or by contacting 1800 789 386 to arrange a time to view the Amendment documentation; the Warrnambool City Council website at [www.warrnambool.vic.gov.au/planning-scheme-amendments](http://www.warrnambool.vic.gov.au/planning-scheme-amendments); on request, during office hours, at the office of the planning authority, Warrnambool City Council, 25 Liebig Street, Warrnambool; or by contacting 03 5559 4800 to arrange a time to view the Amendment documentation.

Any person may make a submission to the planning authority about the Amendment. Submissions must be made in writing giving the submitter's name and contact address, clearly stating the grounds on which the Amendment is supported or opposed and indicating what changes, if any, the submitter wishes to make.

Name and contact details of submitters are required for the planning authority to consider submissions and to notify such persons of the opportunity to attend planning authority meetings and any public hearing held to consider submissions.

The closing date for submissions is 27 February 2025. A submission must be sent to the Warrnambool City Council at 25 Liebig Street, Warrnambool or via email to [planning@warrnambool.vic.gov.au](mailto:planning@warrnambool.vic.gov.au) and marked as Submission on Amendment C219warr.

The planning authority must make a copy of every submission available at its office and/or on its website for any person to inspect, free of charge, until the end of the two months after the Amendment comes into operation or lapses.

ANDREW MASON  
Chief Executive Officer

Creditors, next-of-kin and others having claims against the estate of any of the undermentioned deceased persons are required to send particulars of their claims to State Trustees Limited, ABN 68 064 593 148, of 1 McNab Avenue, Footscray, Victoria 3011, the personal representative, on or before 16 April 2025, after which date State Trustees Limited may convey or distribute the assets, having regard only to the claims of which State Trustees Limited then has notice.

BRANNAN, Keith, late of McGregor Gardens, 11 McGregor Road, Pakenham, Victoria 3810, deceased, who died on 25 December 2024.

BURKE, Jane, late of Regis Armadale Aged Care, 607–613 Dandenong Road, Armadale, Victoria 3143, deceased, who died on 6 July 2024.

BUTTERWORTH, Sheryl Anne, late of Camelia Court Hostel, Unit 4, 14 Tangerine Court, Mount Martha, Victoria 3934, deceased, who died on 7 September 2024.

CAUSON, Joan Irene, late of 2 Lawrence Street, Gosnells, Western Australia 6110, but formerly of 113 Willow Bend, Bulleen, Victoria 3105, deceased, who died on 23 July 2024.

DIVKO, Alan Roland, late of Villa 4, 18 Emerald Street, Collingwood, Victoria 3066, deceased, who died on 28 September 2024.

EPPINGSTALL, Francis, late of 4 James Street, Ringwood, Victoria 3134, deceased, who died on 20 October 2024.

FARLEY, David Henry, late of CraigCare Pascoe Vale, 1A Virginia Street, Pascoe Vale, Victoria 3044, deceased, who died on 26 July 2024.

GLOVER, Andrew Eugene David, late of 18 Wandoo Avenue, Clarinda, Victoria 3169, deceased, who died on 22 May 2024.

LARKINS, Jill, late of Grace McKellar Centre, 45–95 Ballarat Road, North Geelong, Victoria 3215, deceased, who died on 19 July 2024.

LUKEY, Graeme Arthur, late of 33 Reid Park Road, Mount Helen, Victoria 3350, deceased, who died on 12 July 2024.

MALCOLM, Joan Lorraine, late of 24 Barina Avenue, Mooroolbark, Victoria 3138, deceased, who died on 20 September 2024.

MEISCHKE, Christina Cornelia, late of 28 Ritchie Street, Ouyen, Victoria 3490, deceased, who died on 23 September 2024.

SCHROEDER, Maxwell Clement, late of 6 Kaneira Avenue, Croydon, Victoria 3136, deceased, who died on 13 November 2024.

STEVENSON, Kelly Ann, late of 5 Warrington Close, Narre Warren, Victoria 3805, deceased, who died on 14 November 2024.

TAYLOR, Joyce Peggy Ellen, also known as Joyce Peggy Taylor, late of Vasey RSL Care Frankston South, 85 Overport Road, Frankston South, Victoria 3199, deceased, who died on 7 June 2024.

TOWNSEND, Graham, late of Sacred Heart Aged Care, 101 Grey Street, St Kilda, Victoria 3182, deceased, who died on 23 August 2024.

WATSON, Richard James, also known as Richie Watson, late of 6 Athol Avenue, Bundoora, Victoria 3083, deceased, who died on 12 May 2024.

WRIGHT, Patricia Joy, late of Allanvale Private Nursing Home, 38–40 Ascot Street South, Altona Meadows, Victoria 3028, deceased, who died on 20 September 2024.

Dated 5 February 2025

Creditors, next-of-kin and others having claims against the estate of any of the undermentioned deceased persons are required to send particulars of their claims to State Trustees Limited, ABN 68 064 593 148, of 1 McNab Avenue, Footscray, Victoria 3011, the personal representative, on or before 21 April 2025, after which date State Trustees Limited may convey or distribute the assets, having regard only to the claims of which State Trustees Limited then has notice.

ANDERSON, Paul Jonathon, late of Unit 6, 132 Tyler Street, Preston, Victoria 3072, deceased, who died on 6 June 2024.

BUKOWSKI, Robert Joseph, late of Unit 7, 21–23 Airlie Bank Road, Morwell, Victoria 3840, deceased, who died on 12 August 2024.

COUCH, Mary-Anne, late of Beechworth Health Service, 52 Sydney Road, Beechworth, Victoria 3747, deceased, who died on 10 October 2024.

GAZZO, Antonia Gabriella, also known as Antonia Gazzo, late of 71 Melbourne Avenue, Glenroy, Victoria 3046, deceased, who died on 14 July 2023.

GOSS, Royce Gerald, late of Unit 26, 114 Inkerman Street, St Kilda, Victoria 3182, deceased, who died on 4 November 2024.

HENDERSON, Brian Robert, late of Unit 205, 16–20 Stokes Street, Preston, Victoria 3072, deceased, who died on 30 August 2024.

HOLMES, Howard Lee, late of 34 Pearson Street, Bairnsdale, Victoria 3875, deceased, who died on 16 November 2024.

IHLE, Peter James, late of Unit 1, 79 Edwards Street, Wangaratta, Victoria 3677, deceased, who died on 19 August 2024.

JAMES, Diann, late of Uniting AgeWell Noble Park, Room 39, 1312 Heatherton Road, Noble Park, Victoria 3174, deceased, who died on 3 April 2024.

KANE, Phillip John, late of 21 Kofoed Street, Ararat, Victoria 3377, deceased, who died on 19 August 2024.

NAUMOVSKI, Anna, late of Coorondo Home, 597 Warrigal Road, Ashwood, Victoria 3147, deceased, who died on 9 October 2021.

SHERLOCK, Terrance, also known as Terrence W. Sherlock and Terry Sherlock, late of Calvary St Jude's Aged Care, 381–403 Narre Warren North Road, Narre Warren North, Victoria 3804, deceased, who died on 20 October 2024.

TWEDDLE, Margaret Nora Joan, also known as Margaret Joan Tweddle, late of 69 Barkly Street, Sunbury, Victoria 3429, deceased, who died on 12 April 2024.

Dated 10 February 2025

---

### **Electricity Industry Act 2000**

#### **NOTICE OF REVOCATION OF LICENCE TO GENERATE ELECTRICITY**

The Essential Services Commission (the commission) gives notice under section 30(b) of the **Electricity Industry Act 2000** (Industry Act) that, pursuant to section 29(3) of the Industry Act, the commission has revoked the licence of Sustainable Energy Infrastructure Pty Ltd (ACN 625 686 651) (Sustainable Energy Infrastructure) for the generation of electricity. The revocation was with the consent of Sustainable Energy Infrastructure.

GERARD BRODY  
Chairperson

---



**Crown Land (Reserves) Act 1978**

## DAYLESFORD COURT HOUSE AND RESIDENCE RESERVE

Order Giving Approval to Grant a Lease Under Section 17D(3)(a)  
and a Licence Under Section 17BAA (1)(3) of the **Crown Land (Reserves) Act 1978**

Under section 17D(3)(a) and section 17BAA(1)(3) of the **Crown Land (Reserves) Act 1978**, and pursuant to the delegation of 1 January 2024, I, Carolyn Jackson, Deputy Secretary, Regions, Environment, Climate Action and First Peoples, on behalf of the Minister for Environment, am satisfied that there are special reasons which make the granting of a licence and a lease reasonable and appropriate in the particular circumstances and to do this will not be substantially detrimental to the use and enjoyment of any adjacent land reserved under the **Crown Land (Reserves) Act 1978**. I approve the granting of a licence and a lease by Working Heritage Incorporated, as committee of management over the Daylesford Court House and Residence Reserve, to the Daylesford Neighbourhood Centre, described in the schedule below for the purpose of Community and Public Space and, in accordance with section 17D(3)(a) and section 17BAA (1)(3) of the **Crown Land (Reserves) Act 1978**, state that:

- (a) there are special reasons which make granting of a lease and a licence reasonable and appropriate in the circumstances; and
- (b) to do this will not be substantially detrimental to the use and enjoyment of any adjacent land reserved under the **Crown Land (Reserves) Act 1978**.

**SCHEDULE**

The land, being the land shown outlined on Certified Plan CP110132 and Original Plan OP124859 which is Crown land deemed temporarily reserved for the purpose of 'Conservation of an Area of Historic Interest' by Order in Council published in the Government Gazette No. 3 dated 23 January 1991, page 134 and Gazette No.5 dated 6 February 2020, page 304 at Daylesford, being Crown Allotments 37A, Section 37A and Crown Allotment 2041, Township of Daylesford under section 5 of the **Crown Land (Reserves) Act 1978**.

File: 0512717/3003694/3003695

Dated 4 February 2025

CAROLYN JACKSON  
Deputy Secretary Regions, Environment, Climate Action and First Peoples  
(as delegate of the Minister for Environment)

---

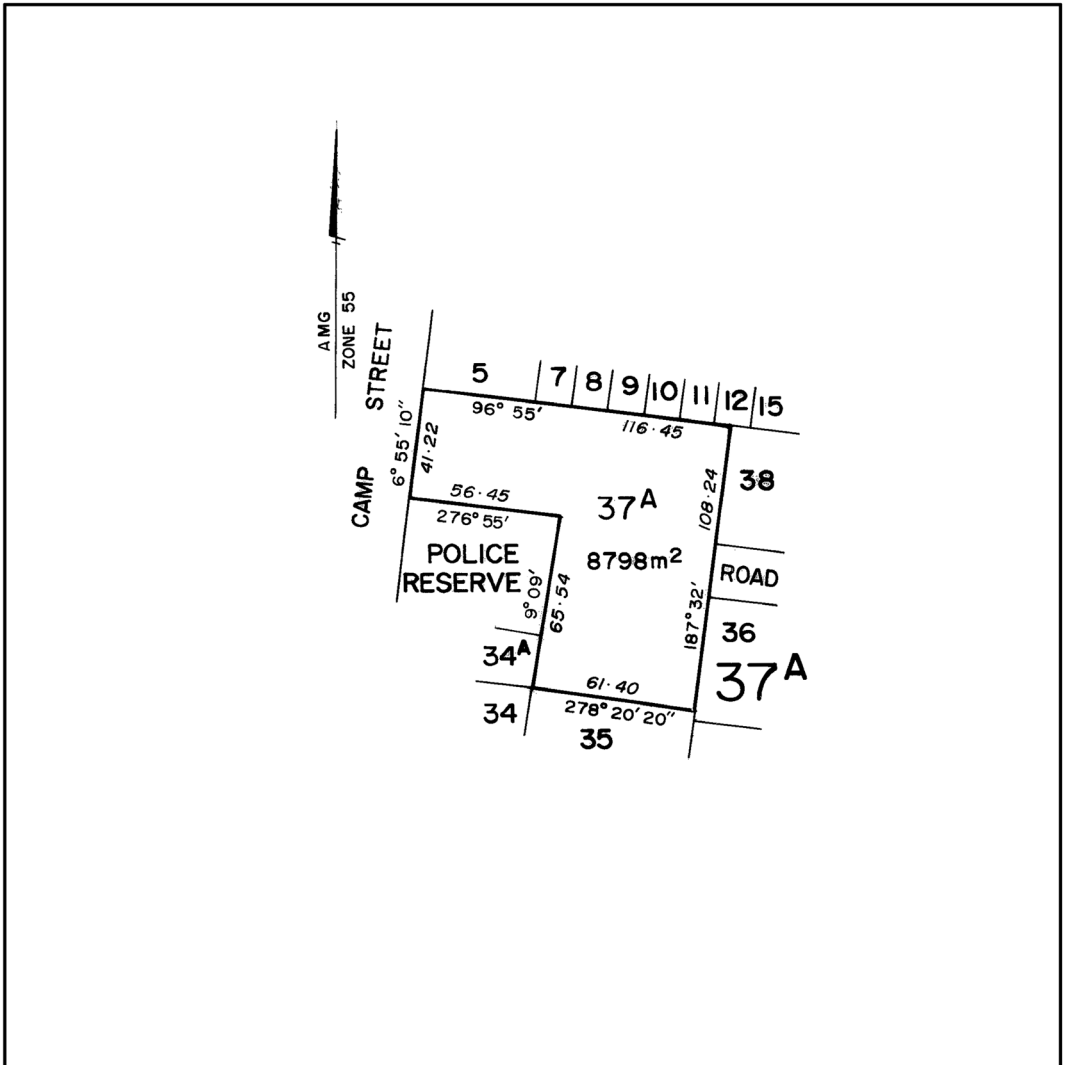

NOTATIONS EXCISION FROM POLICE RESERVE IS NECESSARY

I, Garry F MCKENZIE of STATE OFFICES BALLARAT certify that this plan has been prepared from a survey made under my immediate direction and supervision, in accordance with the Surveyors Act 1978 and completed on 16.5.1990 that this plan is accurate and correctly represents the adopted boundaries and the classification of the survey is C3  
 Date 27.5.1990

*Garry F McKenzie*  
 Licensed Surveyor, Surveyors Act 1978

Examined R.S. 6/6/90 <sup>pm</sup> D 13 (5)

**PLAN OF CROWN ALLOTMENT**

**ACTING SURVEYOR-GENERAL**  
*G. J. Farrell*  
 DATE **19-6-90**

**COUNTY OF TALBOT  
 PARISH OF WOMBAT  
 TOWNSHIP OF DAYLESFORD**

Charted



**DIVISION OF SURVEY AND MAPPING**  
 DEPARTMENT OF PROPERTY AND SERVICES

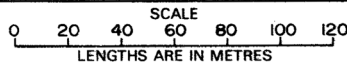

ORIGINAL SCALE SHEET SIZE  
 1:2000 A4

Corr. No L6-2107

**CP 110132**

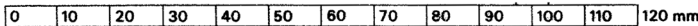

|   |  |   |   |
|---|--|---|---|
| <b>PLAN OF CROWN ALLOTMENT</b>  |  | <b>EDITION 1</b>  | <b>OP124859</b>   |
| <b>LOCATION OF LAND</b><br>COUNTY : TALBOT<br>PARISH : WOMBAT (3857)<br>TOWNSHIP : DAYLESFORD (5231)<br>CROWN ALLOTMENT : 2040 AND 2041<br><br>SPI : 2040\PP5231 AND 2041\PP5231<br>TITLE REFERENCE : C/F VOL.11795 FOL.020 |  | NOTATIONS:  |   |
|   |  |   |   |
| ORIGINAL SHEET SIZE: A3   |  | <b>CERTIFICATION BY SURVEYOR</b>  |   |
| SCALE 1:400<br>4 0 4 8 12 16<br>LENGTHS ARE IN METRES   |  | S   |   |
| FILE REF: 08/470<br>SURVEYORS REF: MEL-68627<br>DRAWN: MH 22/05/2019<br>EXAMINED: AT 4/06/2019  |  | I, Paul Gregory Reidy of 2 Lonsdale Street, Melbourne, VIC, 3000 certify that this plan has been prepared from a survey made under my direction and supervision in accordance with the Surveying Act 2004 and completed on 01/11/2018, that this plan is accurate and correctly represents the adopted boundaries and that the survey accuracy accords with that required by regulation 7(1) of the Surveying (Cadastral Surveys) Regulations 2015.<br><br>Digitally signed by Paul Gregory Reidy 04/06/2019<br>Licensed Surveyor, Surveying Act 2004 |   |
| <b>SURVEYOR-GENERAL VICTORIA</b><br>DEPARTMENT OF ENVIRONMENT,<br>LAND, WATER AND PLANNING  |  | Digitally signed by: Paul Gregory Reidy, Licensed Surveyor,<br>Surveyor's Plan Version (01),<br>04/06/2019, SPEAR Ref: S136699S   | Certified by Craig Leslie Sandy<br>Surveyor-General<br>04:32 PM<br>07/06/2019 |

**Geographic Place Names Act 1998**

## NOTICE OF REGISTRATION OF GEOGRAPHIC NAMES

The Registrar of Geographic Names hereby gives notice of the registration of the undermentioned place names.

Feature Naming:

| <b>Change Request Number</b> | <b>Feature Name</b>  | <b>Authority and Location</b>                                   |
|------------------------------|--|---|
| –                            | Hotham Heights (Alpine Gateway multi-level carpark and day shelter – previously Mt Loch Car Park)<br>Neighbourhood Safer Place | Country Fire Authority  |
| 168861                       | Benmore Street Park  | Wyndham City Council<br>Located at 31 Benmore Street, Mambourin |

Geographic Names Victoria

Land Use Victoria

2 Lonsdale Street

Melbourne 3000

CRAIG L. SANDY

Registrar of Geographic Names

**Geographic Place Names Act 1998**

## CORRIGENDUM

In the Victoria Government Gazette, Notice of Registration, G 6, 6 February 2025, page 160 under **Geographic Place Names Act 1998** feature naming, the feature name Murrungi Wayaparra Community Hub should read ‘Marrungi Wayaparra Community Hub’.

Geographic Names Victoria

Land Use Victoria

2 Lonsdale Street

Melbourne 3000

CRAIG L. SANDY

Registrar of Geographic Names

**Melbourne City Link Act 1995**

## NOTICE OF INSTRUMENT OF DELEGATION

Under section 12 of the **Melbourne City Link Act 1995** (Act), CityLink Melbourne Limited, ACN 070 810 678, the Link corporation, gives notice that, by instrument dated 5 February 2025, it delegated to Transurban Vic Op Co Pty Ltd ACN 621 893 945, the Link operator:

- (a) all road operation and management powers within the meaning of section 62 of the Act conferred on the Link corporation;
- (b) all of its powers and functions under Part 4 of the Act, except section 71 of the Act;
- (c) all of its powers and functions under the regulations made under section 56 of the **Transport (Compliance and Miscellaneous) Act 1983** or under the regulations made under section 132 of the **Road Management Act 2004**; and

(d) all of its powers and functions under section 43 of the **Accident Towing Services Act 2007**, with effect from 10 February 2025, being the date on which Transurban Vic Op Co Pty Ltd was declared as the Link operator.

In this notice:

- (e) the terms, Link corporation and Link operator, have the same meaning as in the Act;
- (f) a reference to:
  - 1) the Act, any provision of the Act, or to any other statute or to any provision of any other statute, includes all regulations, proclamations, ordinances and by-laws (each a Subordinate Instrument), issued under the Act or the statute;
  - 2) the Act, any provision of the Act, or to any other statute or to any provision of any other statute, or to a Subordinate Instrument or provision of a Subordinate Instrument shall, unless the contrary intention appears, be construed:
  - 3) if the Act, statute, Subordinate Instrument, or provision in question has been amended, as a reference to the Act, statute, Subordinate Instrument, or provision as amended and in force for the time being;
  - 4) if the Act, statute, Subordinate Instrument, or provision in question has been re-enacted or re-made (with or without modification), as a reference to the Act, statute, Subordinate Instrument, or provision as re-enacted or re-made and in force for the time being;
  - 5) if the Act, statute, Subordinate Instrument, or provision in question has been re-enacted or re-made (with or without modification) and subsequently amended, as a reference to the Act, statute, Subordinate Instrument, or provision as re-enacted or re-made and as subsequently amended and in force for the time being; and
  - 6) if the Act, statute, Subordinate Instrument, or provision in question has been repealed and not re-enacted or re-made, as a reference to the Act, statute, Subordinate Instrument, or provision as in force immediately before its repeal.

### **Melbourne City Link Act 1995**

#### NOTICE OF INSTRUMENT OF DELEGATION

Under section 12C of the **Melbourne City Link Act 1995** (Act), City Link Extension Pty Limited, ACN 082 058 615, the Extension corporation, gives notice that by instrument dated 5 February 2025, it delegated to Transurban Vic Op Co Pty Ltd ACN 621 893 945, the Extension operator:

- (a) all road operation and management powers within the meaning of section 93I of the Act conferred on the Extension corporation;
- (b) all of its powers and functions under Part 4 of the Act (except the power to fix tolls);
- (c) all of its powers and functions under the regulations made under section 56 of the **Transport (Compliance and Miscellaneous) Act 1983** or under the regulations made under section 132 of the **Road Management Act 2004**; and
- (d) all of its powers and functions under section 42(3) of the **Accident Towing Services Act 2007**, with effect from 10 February 2025, being the date on which Transurban Vic Op Co Pty Ltd was declared as the Link operator.

For the purposes of this instrument of delegation:

- (e) the terms, Extension corporation and Extension operator, have the same meaning as in the Act;

- (f) a reference to:
- 1) the Act, any provision of the Act, or to any other statute or to any provision of any other statute, includes all regulations, proclamations, ordinances and by-laws (each a Subordinate Instrument), issued under the Act or the statute;
  - 2) the Act, any provision of the Act, or to any other statute or to any provision of any other statute, or to a Subordinate Instrument or provision of a Subordinate Instrument shall, unless the contrary intention appears, be construed:
  - 3) if the Act, statute, Subordinate Instrument, or provision in question has been amended, as a reference to the Act, statute, Subordinate Instrument, or provision as amended and in force for the time being;
  - 4) if the Act, statute, Subordinate Instrument, or provision in question has been re-enacted or re-made (with or without modification), as a reference to the Act, statute, Subordinate Instrument, or provision as re-enacted or re-made and in force for the time being;
  - 5) if the Act, statute, Subordinate Instrument, or provision in question has been re-enacted or re-made (with or without modification) and subsequently amended, as a reference to the Act, statute, Subordinate Instrument, or provision as re-enacted or re-made and as subsequently amended and in force for the time being; and
  - 6) if the Act, statute, Subordinate Instrument, or provision in question has been repealed and not re-enacted or re-made, as a reference to the Act, statute, Subordinate Instrument, or provision as in force immediately before its repeal.
- 

### **Plant Biosecurity Act 2010**

#### **ORDER DECLARING RESTRICTED AREAS IN VICTORIA FOR THE CONTROL OF GREEN SNAIL**

I, Stephen Dibley, as delegate of the Minister for Agriculture, being of the reasonable belief that the exotic pest green snail (*Cantareus apertus* (Born)) is present in Victoria, make the following Order under section 32(1) of the **Plant Biosecurity Act 2010**.

#### **1. Objectives**

The objectives of this Order are –

- (a) to declare restricted areas for the control of green snail in Victoria; and
- (b) to specify the prohibitions, restrictions and requirements which are to operate in relation to the restricted areas.

#### **2. Authorising provision**

This Order is made under section 32(1) of the **Plant Biosecurity Act 2010**.

#### **3. Commencement**

This Order comes into operation on the day that it is published in the Government Gazette.

#### **4. Revocation**

The Order entitled *Order declaring restricted areas in Victoria for the control of green snail* made under section 32(1) of the **Plant Biosecurity Act 2010** and published in Victoria Government Gazette G 7 on 15 February 2024 at pages 220–221 is revoked.

#### **5. Definitions**

In this Order –

**host material** means any host plant and any agricultural equipment, used package or earth material associated with the cultivation, harvesting, handling, transport or processing of host plants.

**host plant** means any plant or plant product, including any leafy vegetable, cutting, potted plant, turf, bare rooted plant, mature tree, cut flower, foliage, or hay, but excluding fruit and plants in tissue culture.

**6. Declaration of restricted areas for the control of green snail**

Each parcel of land described in Schedule 1 and Schedule 2 is declared to be a restricted area for the control of green snail.

**7. Affected plants and materials**

This Order affects host materials and host plants defined in clause 5 of this Order.

**8. Prohibitions, restrictions and requirements**

- (1) The removal of any host material from a restricted area described in Schedule 1 is prohibited.
- (2) Subclause (1) does not apply to a person who removes any host material from the restricted area under and in accordance with a permit issued by an inspector and complies with any conditions set out in the permit.
- (3) The removal of any host plant from a restricted area described in Schedule 2 is prohibited.
- (4) Subclause (3) does not apply to a person who removes any host plant from the restricted area under and in accordance with a permit issued by an inspector and complies with any conditions set out in the permit.

**9. Inspector may issue directions**

An inspector is authorised to issue a direction to any owner or occupier of any land described in Schedule 1 –

- (a) requiring the owner or occupier to –
  - (i) destroy any host plant, known or suspected, to be infested with green snail; or
  - (ii) destroy any host plant where this is considered necessary to control or prevent the spread of green snail; or
  - (iii) apply to any host material, or land on which any host material is being grown or propagated, any treatment for the purpose of controlling green snail, including chemicals registered for the control of green snail at rates specified on the label, or in accordance with a permit issued by the Australian Pesticides and Veterinary Medicines Authority (APVMA) for the purpose of controlling green snail; or
  - (iv) clean used equipment; or
- (b) prohibiting the planting or propagation of any host plant for the period specified in the direction.

**8. Expiry**

This Order remains in force for a period of 12 months from the date that it is published in the Government Gazette.

**Schedule 1**

The parcels of land described by Standard Parcel Identifier: Lot 1 of LP85108; Lot 2 of LP97710; Lot 2 of LP146801; Lot 2 of PS300771; Lots 8, 10 and 11 of PS706163; Lots 1 and 2 of TP172348; Lot 1 of TP243174; Lots 1 and 2 of TP515135; Lots 2 and 4 of TP79806.

**Schedule 2**

The parcels of land described by Standard Parcel Identifier: Lots 21 and 22 of LP2308; Lot 3 of LP16185; Lot 1 of LP92345; Lot 1 of LP123399; Lot 1 of LP125889; Lots 1 and 2 of LP139278; Lot 2 of LP140453; Lot 2 of LP140776; Lot 1 of LP142944; Lot 1 of LP206697; Lot 2 of LP206698; Lot 2 of LP206791; Lot 1 of LP211203; Lot 3 of LP215193; Lot 1 of LP216470; Lot 2 of LP217789; PC358473; PC376129; Lots 1 and 3 of PS300771; Lot 2 of PS309134; Lot 2 of PS326225;



Lots 1 and 2 of PS441414; Lots 1, 3 and 4 of PS446195; Lots 1, 2, 3, 4, 5, 6, 7 and 9 of PS706163; RES1 of PS706163; Lot 2 of PS709354; Lots 1 and 2 of PS731160; Lot 2 of PS744191; Lots 3 and 4 of PS846923; Lot 2 of PS846926; Lot 4 of TP107474; Lot 1 of TP189148; Lot 1 of TP194107; Lot 1 of TP212975; Lot 1 of TP214440; Lot 1 of TP215641; Lot 1 of TP338078; Lot 1 of TP580835; Lot 1 of TP743019; Lots 1 and 3 of TP79806; Lot 1 of TP827761; Lot 1 of TP828928; Lot 1 of TP867948; Lot 1 of TP867950; Lot 1 of TP882666; Lots 1 and 2 of TP882806.

Dated 7 February 2025

STEPHEN DIBLEY  
Acting Chief Plant Health Officer

### Road Safety Act 1986

#### DECLARATION UNDER SECTION 99B(4) IN RELATION TO NON-ROAD ACTIVITIES FOR CHILLOUT FESTIVAL STREET PARADE ON SUNDAY 9 MARCH 2025

##### 1 Purpose

The purpose of this Declaration is to exempt participants in the ChillOut Festival Street Parade from specified provisions of the **Road Safety Act 1986** and regulations under that Act with respect to the Event, which is a non-road activity to be conducted on the highway(s) listed in Table 2 on Sunday 9 March 2025.

##### 2 Authorising provision

This notice is made under section 99B(4) of the **Road Safety Act 1986**. Section 99B(4) provides that the Minister for Roads may, on the application of a person proposing to conduct a non-road activity on a highway, by notice published in the Government Gazette, declare that specified provisions of the **Road Safety Act 1986** and of the regulations made under that Act do not apply with respect to the non-road activity specified in the notice during the period specified in the notice.

##### 3 Commencement

This notice takes effect at 7.30 am on Sunday 9 March 2025.

##### 4 Expiry

This notice expires at 12.30 pm on Sunday 9 March 2025.

##### 5 Definitions

In this notice, unless the context or subject-matter otherwise requires –

- a) ‘Event’ means the ChillOut Festival Street Parade, to be held on 9 March 2025; and
- b) ‘Participants’ means participants in the Event, including officers, members and authorised agents of ChillOut Daylesford Inc., whose presence is reasonably required to ensure the safe conduct of the Event.

##### 6 Declaration

I, Michael Bailey, as delegate of the Minister for Roads, under section 99B(4) of the **Road Safety Act 1986** declare that the provisions of the **Road Safety Act 1986** and regulations specified in Table 1 do not apply to Participants engaged in activities forming part of the Event on the highway specified in column 1 of Table 2 on the date and during the period specified in column 2 of Table 2, provided there is full compliance with any conditions imposed by the Department of Transport and Planning and the municipal council.

Dated 29 January 2025

MICHAEL BAILEY  
Executive Director Barwon South West and Grampians  
Department of Transport and Planning  
Delegate of the Minister for Roads

**Table 1**  
**Provisions of the Road Safety Act 1986 and regulations under that Act**  
**that do not apply to participants in the Event**

**Road Safety Act 1986**

|     |
|-----|
| All |
|-----|

**Road Safety Road Rules 2017**

|  |
|--|
| <p><b>1. Load area exemption</b><br/>                 Under Road Rule 268(6)(a), I exempt a driver of a Vehicle from rule 268(4B) of the Road Rules and a Passenger from rule 268(2) of the Road Rules.</p> <p><b>2. Seating exemption</b><br/>                 Under Road Rule 268(6)(a), I exempt a driver of a Vehicle from rules 268(4) and 268(4A) of the Road Rules and a Passenger from rules 268(1) and 268(3) of the Road Rules.</p> <p><b>3. Seatbelt exemption</b><br/>                 Under Road Rule 267(1), I certify that it would be impractical, undesirable or inexpedient for a Passenger who is 7 years old or older to wear a seatbelt. If the Vehicle has 2 or more rows of seats, this exemption does not apply to the front row of seats.</p> <p><b>4. Trailer exemption</b><br/>                 Under Road Rule 298(2)(d) I approve any Trailer for the carriage of passengers, in accordance with the conditions set out in this letter.</p> <p><b>5. Wearing motor bike helmet exemption</b><br/>                 Under Road Rule 270(1)(a), I exempt a rider of a motor bike from rules 270(1)(a) of the Road Rules and a passenger (including the pillion seat), or in a sidecar, from rules 270(1)(a) of the road rules.</p> |
|--|

**Road Safety (Vehicles) Regulations 2021**

|     |
|-----|
| All |
|-----|

**Table 2**

| <i>Column 1</i><br><b>Highway</b>   | <i>Column 2</i><br><b>Date and time</b>       |
|---|---|
| Ballan Daylesford Road (C141)<br>From Stanbridge Street to Midland Highway(A300), Daylesford. | Sunday 9 March 2025, from 7.30 am to 12.30 pm |
| Hepburn Springs Road (C138)<br>From Midland Highway (A300) to Raglan Street, Daylesford.      |   |
| Midland Highway (A300)<br>From Bridport Street to Camp Street, Daylesford.                    |   |



East Gippsland **Water**

**Water Act 1989**

DECLARATION OF SERVICED PROPERTIES

In accordance with section 144 of the **Water Act 1989**, I advise that the following properties have been provided with Reticulated Services and are now liable to be rated as a serviced property for sewerage and/or water service purposes as from the following dates:

| <b>Property Description</b> | <b>Property Address</b>                       | <b>Date</b> | <b>Service</b>  |
|-----------------------------|---|-------------|-----------------|
| Lots 1–2 PS925427           | Angophora Drive, Mallacoota                   | 21.01.2025  | Water and Sewer |
| Lots 1–2 PS925768           | Maude Street, Lucknow                         | 21.01.2025  | Water and Sewer |
| Lots 1–3 PS910693           | Main Street, Bairnsdale                       | 22.01.2025  | Water and Sewer |
| Lots 1–2 PS925447           | Forge Creek Road, Bairnsdale                  | 20.12.2024  | Water           |
| Lots 1–3 PS921666           | Crooke Street, Bairnsdale                     | 24.01.2025  | Water and Sewer |
| Lots 1–4 PS918814           | Byrne Court and Tamhaven Drive,<br>Swan Reach | 29.01.2025  | Water and Sewer |

A plan of the serviced properties is available by contacting the Corporation's office on 1800 671 841 or visiting the Corporation's office at 133 Macleod Street, Bairnsdale.

DAVID RADFORD

General Manager Customer, Community and Communications

**ORDERS IN COUNCIL****Crown Land (Reserves) Act 1978**

## REVOCATION OF TEMPORARY RESERVATIONS

## Order in Council

The Governor in Council under section 10 of the **Crown Land (Reserves) Act 1978** revokes the following temporary reservations:

WEDDERBURN – The temporary reservation by Order in Council of 7 February 1881 of an area of 1.811 hectares, more or less, of land in the Township of Wedderburn as a site for Police purposes, revoked as to parts by Orders in Council of 13 December 1886, 18 June 1985 and 21 February 1995, **so far as the balance remaining** and now described as Crown Allotment 73F, Section U, Township of Wedderburn, Parish of Wedderburne as shown on Crown Diagram No. CD112945W.

File ref: 0617285

ECHUCA – The temporary reservation by Order in Council of 29 December 1868 of an area of 6,070 square metres, more or less, of land in the Township of Echuca as a site for Police purposes, with an additional reservation by Order in Council of 21 November 1938 of an area of 2,023 square metres, revoked as to parts by Orders in Council of 27 October 1964 and 3 August 1971, **so far as the balance remaining** and now described as Crown Allotments 3A, 3B and 3D, Section 3, Township of Echuca, Parish of Echuca North.

File ref: 0607060

BEAUFORT – The temporary reservation by Order in Council of 14 December 1868 of an area of 6,728 square metres, more or less, of land in the Township of Beaufort as a site for Common School purposes.

File ref: 0505573

BEAUFORT – The temporary reservation by Order in Council of 18 July 1961 of an area of 885 square metres, more or less, of land in the Township of Beaufort as a site for State School purposes in addition to and adjoining the site temporarily reserved by Order in Council of 14 December 1868.

File ref: 0505573

BEAUFORT – The temporary reservation by Order in Council of 7 July 1987 of an area of 5,658 square metres of land in the Township of Beaufort as a site for State School purposes.

File ref: 0505865

QUAMBATOOK – The temporary reservation by Order in Council of 19 August 1895 of an area of 6273 square metres, more or less, of land in the Township of Quambatook as a site for Police purposes, revoked as to parts by Orders in Council of 25 November 1969 and 5 November 2008, **so far as the balance** containing 2668 square metres being Crown Allotment 19B, Township of Quambatook, Parish of Quambatook as shown on Original Plan No. OP126900V lodged in the Central Plan Office.

File ref: 0607827

TRUGANINA – The temporary reservation by Order in Council of 27 August 1963 of an area of 733 square metres of land known as Crown Allotment 4D, Section A, Parish of Truganina at Laverton as a site for Police purposes.

File ref: 0704893

TRUGANINA – The temporary reservation by Order in Council of 17 December 1974 of an area of 847 square metres of land known as Crown Allotment 4C, Section A, Parish of Truganina as a site for Police purposes.

File ref: 0704892

BENALLA – The temporary reservation by Order in Council of 29 September 2015 of an area of 3586 square metres of land known as Crown Allotment 2009, Township of Benalla, Parish of Benalla as a site for Public purposes (Court purposes).

File ref: 2022213

BENALLA – The temporary reservation by Order in Council of 29 September 2015 of an area of 6428 square metres of land known as Crown Allotment 2010, Township of Benalla, Parish of Benalla as a site for Public purposes (Police purposes).

File ref: 2022214

This Order comes into effect on the date it is published in the Government Gazette.

Dated: 11 February 2025

Responsible Minister:

STEVE DIMOPOULOS

Minister for Environment

SAMUAL WALLACE  
Clerk of the Executive Council

---

### **Crown Land (Reserves) Act 1978**

#### **DISSOLUTION OF INCORPORATED COMMITTEE OF MANAGEMENT**

##### **Order in Council**

The Governor in Council, under section 14A(7) of the **Crown Land (Reserves) Act 1978**, dissolves the incorporated committees of management described hereunder:–

**Bendoc Recreation Reserve Committee of Management Incorporated** constituted by Order in Council of 20 July 1999 and published in the Government Gazette on 22 July 1999, page 1722;

File ref: 1604305

**Sarsfield Recreation Reserve Committee of Management Incorporated** constituted by Order in Council of 31 October 1995 and published in the Government Gazette on 2 November 1995, page 3077;

File ref: 1601485

**Nowa Nowa Public Hall Reserve Committee of Management Incorporated** constituted by Order in Council of 7 April 1999 and published in the Government Gazette on 8 April 1999, page 823.

File ref: 1601519

This Order comes into effect on the date it is published in the Government Gazette.

Dated: 11 February 2025

Responsible Minister:

STEVE DIMOPOULOS

Minister for Environment

SAMUAL WALLACE  
Clerk of the Executive Council

---

**Crown Land (Reserves) Act 1978**

TEMPORARY RESERVATIONS OF CROWN LANDS

Order in Council

The Governor in Council under section 4(1) of the **Crown Land (Reserves) Act 1978** temporarily reserves the following Crown lands which are required for the purposes mentioned:–

MUNICIPAL DISTRICT OF THE EAST GIPPSLAND SHIRE COUNCIL

NEWMERELLA – Public purposes (Rail Trail); area 3.3 hectares, being Crown Allotments 2003 and 2004, Township of Newmerella, Parish of Newmerella as shown on Plan No. LEGL./21-573 lodged in the Central Plan Office.

File ref: 2000112

MUNICIPAL DISTRICT OF THE SWAN HILL RURAL CITY COUNCIL

MANANGATANG – Public recreation; area 4841 square metres, being Crown Allotment 17A, Section 4, Township of Manangatang, Parish of Manangatang as shown on Original Plan No. CP110456 lodged in the Central Plan Office.

File ref: 0103999

MUNICIPAL DISTRICT OF THE GREATER BENDIGO CITY COUNCIL

HUNTLY – Public purposes (Carpark); area 2184 square metres, being Crown Allotment 2130, Parish of Huntly and Crown Allotment 2131, Parish of Huntly being part of the land described in Government Gazette of 18 March 1881 page 817 permanently reserved for Public purposes by Orders in Council of 23 May 1881, as shown on Original Plan No. OP126590J lodged in the Central Plan Office.

File ref: 06P127138

MUNICIPAL DISTRICT OF THE STRATHBOGIE SHIRE COUNCIL

TABILK – Public purposes (Ambulance Station); area 1673 square metres, being Crown Allotment 2014, Parish of Tabilk as shown on Original Plan No. OP126734L lodged in the Central Plan Office.

File ref: P529022

MUNICIPAL DISTRICT OF THE STRATHBOGIE SHIRE COUNCIL

TABILK – Public purposes (Police purposes); area 1839 square metres, being Crown Allotment 2013, Parish of Tabilk as shown on Original Plan No. OP126734L lodged in the Central Plan Office.

File ref: P529021

This Order comes into effect on the date it is published in the Government Gazette.

Dated: 11 February 2025

Responsible Minister:

STEVE DIMOPOULOS

Minister for Environment

SAMUAL WALLACE  
Clerk of the Executive Council

---

**Land Act 1958**

## CLOSURE OF UNUSED ROADS

## Order in Council

The Governor in Council under section 349 of the **Land Act 1958** and with the concurrence in writing of the municipalities in which the roads are situated and the owner/s of any land adjoining the roads closes the following unused roads:

## MUNICIPAL DISTRICT OF THE BAW BAW SHIRE COUNCIL

DROUIN WEST – The road in the Parish of Drouin West being Crown Allotment 2080 [2911 square metres] as shown on Original Plan No. OP126896H lodged in the Central Plan Office.  
File ref: 15L10.8172

## MUNICIPAL DISTRICT OF THE CITY OF GREATER GEELONG COUNCIL

WURDI-YOuang – The road in the Parish of Wurdi-Youang being Crown Allotment 2030 [2881 square metres] as shown on Original Plan No. OP126999W lodged in the Central Plan Office.  
File ref: 0702799

This Order comes into effect on the date it is published in the Government Gazette.

Dated: 11 February 2025

Responsible Minister:

STEVE DIMOPOULOS  
Minister for Environment

SAMUAL WALLACE  
Clerk of the Executive Council

**Major Transport Projects Facilitation Act 2009**

## REVOCATION OF PERMANENT AND TEMPORARY RESERVATION

## Order in Council

The Governor in Council under section 139(2) of the **Major Transport Projects Facilitation Act 2009**, revokes the following permanent and temporary reservations:

The permanent reservation for public purposes by Order dated 23 May 1881 and published in the Government Gazette on 27 May 1881, page 1389.

MORDIALLOC – The temporary reservation for public park by Order dated 15 August 1898 and published in the Government Gazette on 19 August 1898, page 3114.

MORDIALLOC – The temporary reservation for public park by Order dated 7 April 1897 and published in the Government Gazette on 15 April 1897, page 1668.

MORDIALLOC – The temporary reservation for public park by Order dated 30 October 1873 and published in the Government Gazette on 7 November 1873, page 1962.

described as Crown Allotment 2080 Parish of Mordialloc, being the land contained in Crown Folio Statement Volume 12574 Folio 761 and as shown on Plan of Crown Allotment OP126951C.

This Order is effective from the date it is published in the Government Gazette.

Dated: 11 February 2025

Responsible Minister:

THE HON GABRIELLE WILLIAMS MP  
Minister for Transport Infrastructure

SAMUAL WALLACE  
Clerk of the Executive Council



**SUBORDINATE LEGISLATION ACT 1994  
NOTICE THAT STATUTORY RULES ARE  
OBTAINABLE**

Notice is hereby given under section 17(3) of the **Subordinate Legislation Act 1994** that the following Statutory Rule was first obtainable from TIMG Bookshop, Level 10, 575 Bourke Street, Melbourne 3000, on the date specified:

1. *Statutory Rule:* Food (Primary  
Production and  
Processing)  
Regulations 2025
- Authorising Act:* Food Act 1984
- Date first obtainable:* 11 February 2025
- Code D*
-

## PRICING FOR SPECIAL GAZETTE, PERIODICAL GAZETTE AND VICTORIAN LEGISLATION

Retail price varies according to the number of pages in each Victoria Government Special Gazette, Victoria Government Periodical Gazette and Victorian legislation. The table below sets out the prices that apply. Prices apply from 1 January 2025.

| <i>Price Code</i> | <i>No. of Pages (Including cover and blank pages)</i> | <i>Price*</i> |
|-------------------|---|---------------|
| A                 | 1–16  | \$4.61        |
| B                 | 17–32   | \$6.91        |
| C                 | 33–48   | \$9.45        |
| D                 | 49–96   | \$15.91       |
| E                 | 97–144  | \$20.46       |
| F                 | 145–192   | \$24.29       |
| G                 | 193–240   | \$27.99       |
| H                 | 241–288   | \$29.72       |
| I                 | 289–352   | \$33.23       |
| J                 | 353–416   | \$38.71       |
| K                 | 417–480   | \$43.80       |
| L                 | 481–544   | \$51.06       |
| M                 | 545–608   | \$58.38       |
| N                 | 609–672   | \$64.55       |
| O                 | 673–736   | \$72.97       |
| P                 | 737–800   | \$80.41       |
| #Q                | 821–886   | \$86.58       |
| #R                | 887–950   | \$92.36       |
| #S                | 951–1016  | \$98.65       |
| #T                | 1017–1080   | \$104.66      |
| #U                | 1081–1146   | \$111.06      |
| #V                | 1147–1210   | \$116.46      |
| #W                | 1211–1276   | \$122.50      |
| #X                | 1277–1340   | \$129.15      |
| #Y                | 1341–1406   | \$134.96      |

| <i>Price Code</i> | <i>No. of Pages (Including cover and blank pages)</i> | <i>Price*</i> |
|-------------------|---|---------------|
| #Z                | 1407–1470   | \$141.33      |
| #ZA               | 1471–1536   | \$148.03      |
| #ZB               | 1537–1610   | \$152.92      |
| #ZC               | 1611–1666   | \$159.23      |
| #ZD               | 1667–1730   | \$165.39      |
| #ZE               | 1731–1796   | \$172.00      |
| #ZF               | 1797–1860   | \$178.29      |
| #ZG               | 1861–1926   | \$183.24      |
| #ZH               | 1927–1990   | \$190.32      |
| #ZI               | 1991–2056   | \$195.84      |

\* All prices include GST  
# Printed as two volumes

# ive

The *Victoria Government Gazette* is published by IVE Group Limited with the authority of the Government Printer for the State of Victoria

© State of Victoria 2025

This publication is copyright. No part may be reproduced by any process except in accordance with the provisions of the Copyright Act.

Address all enquiries to the Government Printer for the State of Victoria  
Level 2, 1 Macarthur Street  
Melbourne 3002  
Victoria, Australia

## How To Order



**Retail &  
Mail Sales**

**Victoria Government Gazette**  
Ground Floor, Building 8,  
658 Church Street,  
Richmond 3121



**Telephone**

03 8523 4601

**email**

[gazette@ivegroup.com.au](mailto:gazette@ivegroup.com.au)

**Recommended Retail Price \$2.55 (includes GST)**